

**Please cite the Published Version**

Owda, Amani and Salmon, Neil  (2020) Millimetric radiometry for measuring human and porcine skin reflectance. In: SPIE Security + Defence, 2020, 21 September 2020 - 25 September 2020, Virtual.

**DOI:** <https://doi.org/10.1117/12.2576376>

**Publisher:** SPIE

**Version:** Accepted Version

**Downloaded from:** <https://e-space.mmu.ac.uk/626701/>

**Additional Information:** Copyright 2020 Society of PhotoOptical Instrumentation Engineers (SPIE). One print or electronic copy may be made for personal use only. Systematic reproduction and distribution, duplication of any material in this publication for a fee or for commercial purposes, and modification of the contents of the publication are prohibited.

**Enquiries:**

If you have questions about this document, contact [openresearch@mmu.ac.uk](mailto:openresearch@mmu.ac.uk). Please include the URL of the record in e-space. If you believe that your, or a third party's rights have been compromised through this document please see our Take Down policy (available from <https://www.mmu.ac.uk/library/using-the-library/policies-and-guidelines>)

# Millimetric Radiometry for Measuring Human and Porcine Skin Reflectance

Amani Yousef Owda<sup>1\*</sup>, Neil Salmon<sup>2</sup>

<sup>1</sup>Department of Electrical and Electronic Engineering, The University of Manchester, M13 9PL, UK

<sup>2</sup>Department of Engineering, Manchester Metropolitan University, M1 5GD, UK

## ABSTRACT

Despite the rising interest in the human skin signature over the millimetre wave band there is relatively little information about the human skin reflectance and the dielectric properties of the human skin, and how these vary with locations and between gender, and hydration level of the skin. This paper has investigated the reflectance of the human skin over the frequency band 80-100 GHz, and comparing the reflectance of the human skin with the reflectance of porcine skin samples under normal and wet skin conditions.

For a sample of 60 healthy participants (36 males and 24 females) the mean reflectance of the skin over all measurement locations was found to be  $\sim 0.606$  with a standard deviation of  $\sim 0.086$ . The skin regions of the palm of the hand, the outer wrist and the dorsal forearm skin had reflectances 0.068, 0.058 and 0.0677 lower than the skin regions of the back of the hand, the inner wrist and the volar forearms respectively. Reflectance measurements of human skin under normal and wet state on the palm of the hand and the back of the hand regions indicate that the mean differences in the reflectance before and after the application of water is  $\sim 0.15$  and  $\sim 0.075$  respectively. A comparison in reflectance between human skin and porcine skin samples indicates similar trends in signatures between ex-vivo porcine skin samples and human skin.

During the cycle of life, human skin is affected by many factors such as the age, the environment, the interaction with different types of radiation, genetic defects, dehydration, and accidents. These factors might cause diseases, temporal skin conditions, and permanent disorders. In response to this, the skin presents signatures, which can be measured using non-contact millimetre wave sensors that could quantify the degree of the damage. These unique findings enable millimetre wave radiometry to be used for detecting human skin signatures and anomalies under different conditions by identifying unusually high or low levels of reflectance in tens of seconds.

**Keywords:** Reflectance; millimetre waves; signatures; radiometry; passive sensing.

## 1. INTRODUCTION

Our previous studies [1, 2, 3, 4, 5, 6, 7, 8, 9] show strong correlation between skin emissivity, skin thickness, water content and hydration level, all of which vary with age, gender and body site. [1] Suggests age-related trends in the emissivity of the skin for males and female participants in the age group 50-60 years. These trends are consistent with the fact that water content and skin hydration level decrease with the age. Furthermore, [2] reveals that radiometric sensitivity is sufficient to sense different surfaces attached to the human skin such as water and as a result, it provides a clear signature between normal and wet skin and also between thinner and thicker skin regions. [3, 4] show the signature of the human skin and how it varies with physical activity and hydration level of the skin. [5, 6, 7] Illustrates the capability of the radiometer to sense through some type of bandages and distinguish between healthy skin and burn-damaged skin. These findings suggested that millimetre wave radiometry can be used as a new type of medical diagnostic, potentially to identify unusually high or low levels of emissivity and reflectance which may indicate unhealthy skin or dry skin conditions. This is also confirmed by the half space model [8] that suggests radiometry as a non-contact viable technique to detect and monitor skin disease or damage, where the disease or the damage alters the water content or the skin thickness such as eczema, dehydration, malignancy, psoriasis and burn wounds.

\*amaniabubaha@gmail.com; The University of Manchester; mobile number +44 7402 939 756.

The implications of having radiometry as a non-contact sensor for non-invasive diagnosis of skin diseases (or conditions) where the water content and the skin thickness are highly affected, is that early detection of skin disease [9]. A capability that will save lives and reduces the risk; pain; number of people admits to hospital; cost of Healthcare, and distress caused by long waiting hours as well as reduces the healthcare interventional time. In this paper, the signature of the human skin was measured for a sample of 60 healthy participants and compared with porcine skin samples to assess possible similarities in signature between human skin and ex-vivo porcine skin samples over the band 80-100 GHz for both normal skin and skin saturated with water. Reflectance measurements in this study demonstrate the potential usefulness of the proposed W-band radiometer to be used as a non-contact sensor for security screening and medical applications.

## 2. MILLIMETRIC RADIOMETRY

A radiometer is a device that is used to measure the thermal (Planck) radiation which looks like a thermal noise in character [10] and for radiation frequencies below the mid-infrared band ( $hf < kT$ ) the intensity of the emission is directly proportional to the thermodynamic temperature of the object, enabling calibration in degrees Kelvin [11]. Materials in the MMW band have certain reflectance ranging from almost zero for highly absorbing materials to unity for metals. The level of reflectance is dependent on the dielectric properties of the materials and is described by the Fresnel equations [12]. The skin also has a reflectance and as such measurement will include emission from the skin but also emission from the surroundings which becomes reflected from the skin into the radiometer antenna. In radiometry, the total amount of radiation includes radiation from the target, radiation from the radiometer, and radiation from the environment; as illustrated in Figure 1. This radiation is dependent on the architecture of the radiometer and it is an essential requirement to distinguish between two types of received radiations; 1) the noise power received from the target source, and 2) the unwanted noise generated by the receiver (the noise temperature of the radiometer) [10].

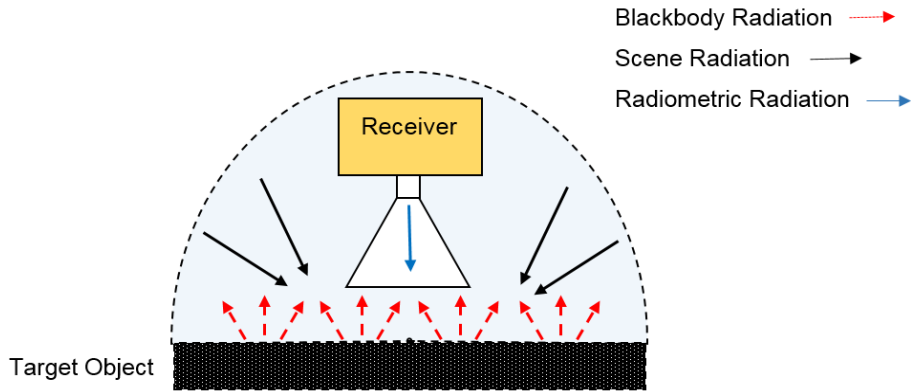

Figure 1. General schematic for a radiometer collecting uniform thermal emissions from a blackbody (foam absorber). The horn antenna collects the emission and generates a fluctuating voltage, and the receiver amplifies and detects the emission.

The horn antenna in Figure 1 is directed toward radiating thermal emissions from a target object, collects the emission, and generates a fluctuation voltage (the fluctuating voltage is a result of the radiometer equation (Equation 1)). Then the voltage level is amplified and detected through the receiver [10].

$$\Delta T_{\min} = \frac{T_A + T_R}{\sqrt{Bt}} \quad (1)$$

Where,  $t$  is the post-detection integration time,  $T_R$  is the receiver noise temperature,  $B$  is the receiver bandwidth, and  $T_A$  is the antenna radiation temperature, effectively the radiation temperature of the source in front of the antenna [12].

### 3. EXPERIMENTAL METHODOLOGY

#### 3.1 Participants

Sixty healthy participants (36 males and 24 females) with no history of skin disease were recruited in this study. The participants had a mean and a standard deviation ( $\pm$ SD) in their age:  $33.6 \pm 8.79$  years, mass:  $74.3 \pm 15.92$  kg, and height:  $1.74 \pm 0.087$  m. The study was approved by the ethical committee of Manchester Metropolitan University under ethics reference no: SE151630CA1.

#### 3.2 Porcine skin

In this research, four porcine skin samples were purchased from an abattoir and the measurements were conducted on these for a time of up to no longer than four hours after the slaughter. The samples were taken from pig having age of eight months and an average weight of 60 kg. The samples were taken from the back region of the same animal. This region is chosen since it is free from hair follicle and sweat glands. The study was approved by the ethics committee of Manchester Metropolitan University (ethics reference no: SE1617114C).

#### 3.3 Experimental setup

A radiometer, integrating the emission over the frequency band 80-100 GHz, was used for measuring the reflectance of the skin. The equipment for measurement consisted of a W-band horn antenna connected directly to the Millimeter-Wave Monolithic Integrated Circuit (MMIC) detector. The output of the detector was connected through a coaxial cable to a digital voltmeter and through wires to a DC power supply, as illustrated in Figure 2.

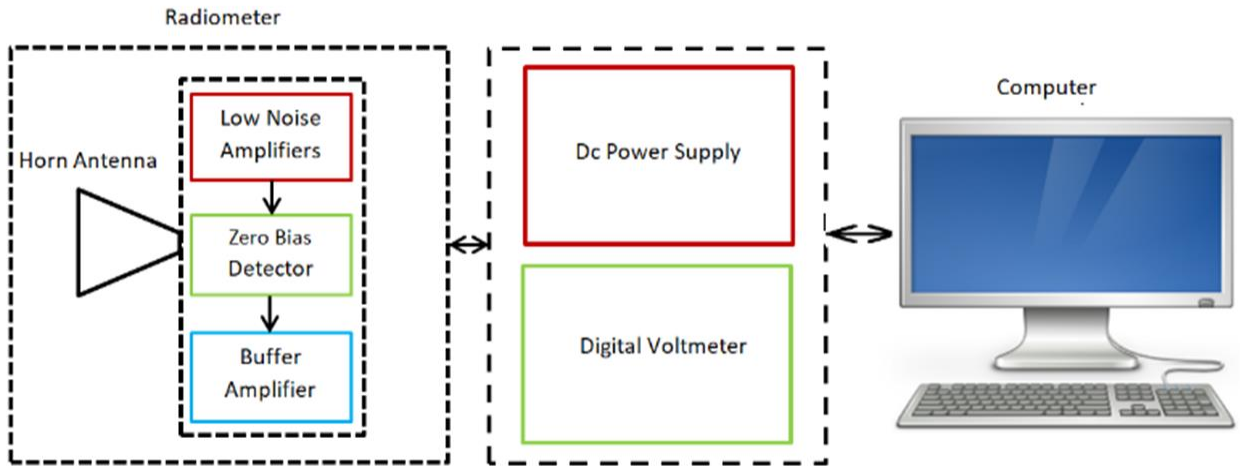

Figure. 2. The main elements of the experimental work: A horn antenna connected to MMIC detector (consisting of a two-stage low-noise amplifier; zero bias diode detector and buffer amplifier).

Two pieces of carbon loaded foam absorbers (type: Eccosorb AN-73) acted as hot and cold load calibration sources; the absorbers had a rectangular shape and dimensions (length=170 mm, width=150 mm, and thickness 10 mm). These dimensions were chosen to fill the beam pattern of the horn antenna and to reduce the systematic uncertainty during the calibration. The output of the receiver in Volts for ambient temperature source calibration can be expressed as [9, 12]:

$$V_H = \alpha(T_H + T_N) \quad (2)$$

Where,  $T_H$  is the hot load temperature in Kelvin,  $\alpha$  is the receiver responsivity in Volts per Kelvin, and  $T_N$  is the receiver noise temperature in Kelvin.

For the liquid nitrogen source calibration, the output of the receiver is [9, 12]:

$$V_C = \alpha(T_C + T_N) \quad (3)$$

From Equations (2) and (3) the receiver responsivity,  $\alpha$ , and the emissivity of the skin,  $\eta$ , are [9, 12]:

$$\alpha = \frac{(V_H - V_C)}{(T_H - T_C)} \quad (4)$$

$$\eta = \frac{(V_S - V_H)(T_H - T_C)}{(V_H - V_C)(T_S - T_H)} \quad (5)$$

Conservation of electromagnetic energy provides a relationship between the emissivity  $\eta$ , the reflectance  $R$ , and the transmittance  $T$  of the skin surface as [9, 12]:

$$I = R + T + \eta \quad (6)$$

As the human skin is opaque ( $T=0$ ) [5], the reflectance of the skin can be expressed as:

$$R = I - \eta \quad (7)$$

By substituting (5) in (7), the reflectance of the skin is [9]:

$$R = \frac{T_C(V_S - V_H) + T_S(V_H - V_C) + T_H(V_C - V_S)}{(V_H - V_C)(T_S - T_H)} \quad (8)$$

An infrared thermometer with an absolute measurement uncertainty of  $\pm 1.5$  °C was used to measure the temperatures of the human skin,  $T_S$  directly before and after the measurements. A digital voltmeter was used to measure the output voltage for the target area of the skin,  $V_S$ . Typical the voltage measurements were up to 100 mV with a precision of 0.1 mV. Error propagation through (8) indicates that the uncertainty on the measured reflectance is  $\pm 0.005$ .

### 3.4 Methodology for measuring human skin reflectance

The radiometer was calibrated using liquid nitrogen and ambient temperature sources. The horn antenna of the radiometer placed at distance ( $\sim 5.0$  cm) from two different radiation sources located in the same plane: “Hot” black body (ambient temperature source calibration). A piece of carbon loaded foam absorber with  $T_H = T_{ambient} = 293$  K, and “Cold” black body (liquid nitrogen source calibration). A piece of carbon loaded foam absorber was dipped in liquid nitrogen at  $T_C = 77$  K. The cold load calibration measurements were taken within 5 seconds or less before the liquid nitrogen evaporates. These measurements were taken from ten separate experiments and at each experiment, the calibration measurements were repeated 5-10 times so the device was stable and the measurements were consistent.

Measurements of human skin reflectance of 36 male and 24 female participants were made using the calibrated radiometer of Figure 2 and Equation (8). The measurements were performed over the frequency band (80-100) GHz and they were repeated (5-10) times at each location of the arm, these being: 1) the palm of the hand, 2) the back of the hand, 3) the inner wrist, 4) the outer wrist, 5) the dorsal surface of the forearm, and 6) the volar side of the forearm. Then the measurements were repeated on the palm of the hand and the back of the hand before and after the application of water.

### 3.5 Methodology for measuring porcine skin reflectance

The 90 GHz calibrated radiometer is used for measuring the mean reflectance values of the porcine skin samples before and after the applications of water and cream. The samples were located over a digital hotplate as illustrated in Figure 3.

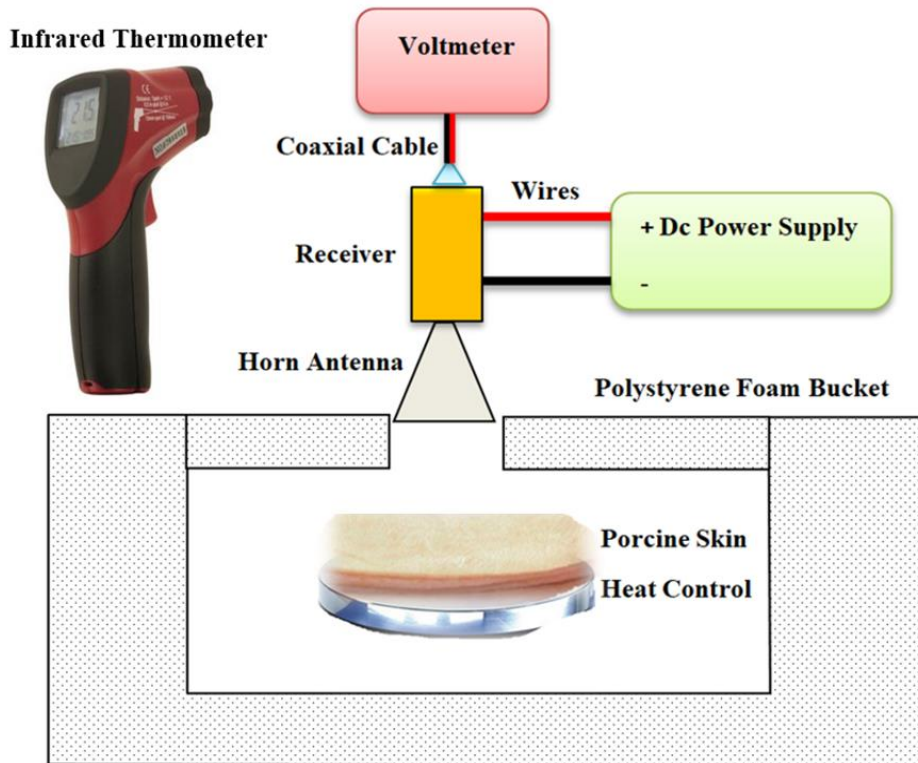

Figure 3. The experimental setup for the reflectance measurements of the porcine skin samples. A digital voltmeter is used to measure the output voltage level of the samples and a thermocouple and an infrared thermometer are used to measure the thermodynamic temperature of the samples.

The samples were located on the digital hot plate and left to be heated and stabilised to 37 °C. This temperature is chosen since it is closed to the in vivo surface temperature of the porcine skin ~35 °C [13]. Then the calibrated radiometer of Figure 3 was used to measure the voltage level of the thermal emission emitted from the samples and an infrared thermometer was used to measure the skin surface temperature. The measurements were repeated five times and processed using Equation (8). All measurements presented in Figure 3 were made over a distance of ~5.0 cm from the horn antenna to minimize the chances of subjects touching the measurement apparatus.

For measuring the skin reflectance after the application of water, the samples were located over a digital hotplate and left to be heated and stabilised to 37 °C. A thin layer of water was placed on the skin surface for a period of time ranging from 2.0 minutes to 4.0 minutes until the water is just absorbed (but not evaporated). Then reflectance measurements were conducted directly and quickly using the calibrated radiometer of Figure 3 and Equation (8).

For the cream, a thin layer of different types of cream such as Savlon, Sudocrem, and Flamazine was placed on the skin surface for a period of time ranging from 2.0 minutes to 4.0 minutes until the cream is absorbed. Then reflectance measurements were conducted directly and quickly using the calibrated radiometer of Figure 3 and Equation (8).

## 4. RESULTS AND DISCUSSION

This section presents reflectance measurements of human skin and ex-vivo porcine skin samples under normal and moistened conditions.

### 4.1. Skin reflectance for male and female participants

The measurements over a sample of 60 participants indicate that human skin reflectance varies from person to person for both genders. These are likely to be due to the variations in skin thickness, water content and blood circulation [9], these factors having some dependency on weather conditions, the time of day, the age, the gender, and the state of health of the participants. The mean ( $\mu$ ), the standard deviation ( $\sigma$ ), and the standard error in the mean ( $\sigma/\sqrt{n}$ ; where  $n$  is the sample size) of the reflectance over a sample of 60 participants for all measurements locations are presented in Table 1.

Location	Mean reflectance $\pm$ standard deviation for whole sample (sample size=60)	Standard error in the mean for the whole sample ( $\sigma/\sqrt{60}$ )	Mean reflectance $\pm$ standard deviation for the male sample (sample size=36)	Standard error in the mean for the male sample ( $\sigma/\sqrt{36}$ )	Mean reflectance $\pm$ standard deviation for female sample (sample size =24)	Standard error in the mean for the female sample ( $\sigma/\sqrt{24}$ )
The palm of the hand	0.5549 $\pm$ 0.0938 Range: 0.4611-0.6487	0.0121	0.5449 $\pm$ 0.0916	0.0153	0.5699 $\pm$ 0.095	0.0194
The back of the hand	0.6231 $\pm$ 0.0883 Range: 0.5348-0.7114	0.0114	0.6187 $\pm$ 0.090	0.0150	0.6296 $\pm$ 0.0851	0.0174
The outer wrist	0.6114 $\pm$ 0.0623 Range: 0.5491-0.6737	0.0080	0.6033 $\pm$ 0.0599	0.0099	0.6237 $\pm$ 0.0636	0.0129
The inner wrist	0.6694 $\pm$ 0.0642 Range: 0.6052-0.7336	0.0083	0.6568 $\pm$ 0.0642	0.0107	0.6882 $\pm$ 0.0596	0.0122
The dorsal surface	0.5556 $\pm$ 0.0734 Range: 0.4822-0.6290	0.0095	0.5514 $\pm$ 0.0778	0.0129	0.5619 $\pm$ 0.0659	0.0135
The volar side	0.6233 $\pm$ 0.0672 Range: 0.5561-0.6905	0.0087	0.6189 $\pm$ 0.0725	0.0120	0.6298 $\pm$ 0.0578	0.0118

Table 1: Human skin reflectance for a sample of sixty healthy participants over the frequency band (80 -100) GHz.

Experimental measurements of a sample of 36 male participants, illustrated in Table 1, indicate that the mean differences in the reflectance values between palm of hand and back of hand, the dorsal and volar regions of the forearm, and the inner and the outer wrist locations are: 0.0738, 0.0675 and 0.0535 with a sample standard deviation in the differences of 0.041, 0.03199 and 0.0336 respectively. These differences are approximately 10 times the standard error in the mean and 13 times the systematic uncertainty. These differences in reflectance are likely to be due to the thicker and thinner skin regions. The thinner skin regions of the back of the hand, the volar side of the forearm and the inner wrist [14] make the blood vessels closer to the skin surface and this increases the reflectance of the human skin substantially, whereas the thicker skin regions of the palm of the hand, the dorsal surface of the forearm and the outer wrist [14] make the blood vessels far from the skin surface and this makes the reflectance of the skin lower than that of the thinner skin regions.

The sample mean of the differences in the reflectance values between thinner and thicker skin regions over a sample of 24 female participants, illustrated in Table 1, are: 0.0597, 0.0679 and 0.0645 respectively with a standard deviation in the differences of 0.0365, 0.0449, and 0.0395. These differences are approximately 8 times the standard error of the mean and 13 times the systematic uncertainty. This indicates substantial differences in the reflectance between thinner and thicker skin regions.

Experimental measurements of the reflectance of a sample of 60 participants indicate a scatter in the mean reflectance of individuals in the range of 0.323 to 0.83. Estimating the sample mean reflectance values for the 36 males and 24 females separately indicates that the difference between male and female reflectance at all measurement locations is  $\sim$ 0.02. This difference is likely to be due to the skin of males being thicker than that of females in all ages [15].

## 4.2 Skin reflectance for male and female participants before and after the application of water

It is an accepted fact that water content of the skin dominates its electromagnetic behavior in the millimeter wave band [16], so a measurement was made to quantify this statement at a 90 GHz. Firstly reflectance measurements of normal clean skin on the palm and the back of hand were made. Then these areas of the skin were covered with water, which was then left to be absorbed for 2-4 minutes. After such time, when there was no water left visible on the skin, second measurements of the reflectance were made. This methodology was applied on 12 healthy participants (6 male and 6 female) and the mean reflectances for the males and females are shown in Figure 4 (a) and Figure 4 (b).

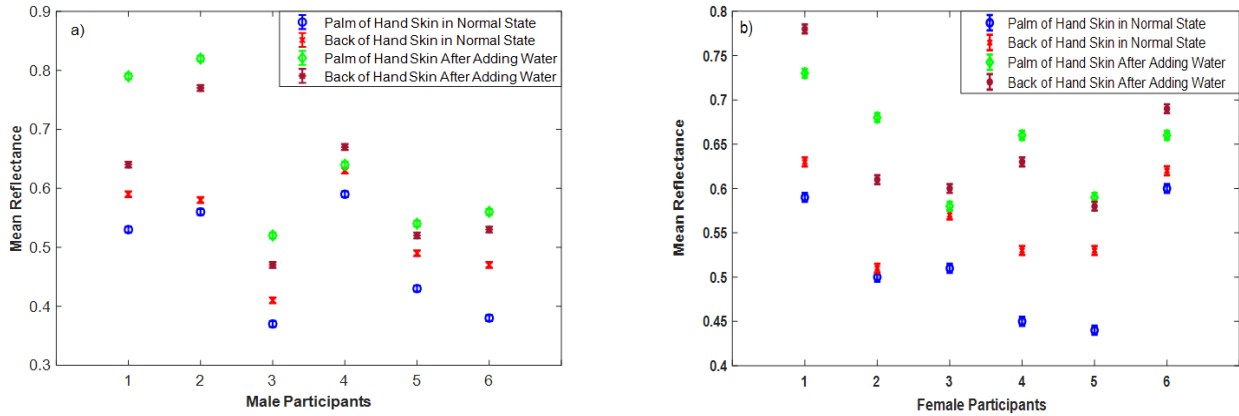

Figure 4. Mean reflectance for the palm of the hand and the back of the hand skin before and after the application of water for male (a) and female (b) participants.

Experimental measurements for a sample of 6 male participants in Figure 4 (a) indicate that the mean reflectance values for the palm of the hand skin and the back of the hand skin after adding water is substantially higher than the mean reflectance of the skin in normal state for the two measurements locations. Statistical analysis on the data indicates that the mean difference in reflectance for the palm of the hand skin before and after moistening with water is  $\sim 0.154$  with a sample standard deviation in the reflectance of  $\sim 0.074$ . The mean difference in the reflectance for the back of the hand skin before and after adding water is  $\sim 0.066$  with a standard deviation in the reflectance of  $\sim 0.045$ . Our methodology suggests that these differences are due to the water that increases the hydration level of the skin and this makes the reflectance of the skin higher [17].

Experimental measurements for a sample of 6 female participants in Figure 4 (b) show that the mean reflectance for the palm of the hand skin and the back of the hand skin after moistening with water is higher than that of the palm of the hand and the back of the hand skin before adding water by mean values of 0.148 and 0.0833 and standard deviations of 0.054 and 0.039 respectively. The differences between the wet and the normal palm of hand skin are higher than that of the back of the hand skin for both males and females participants, and this is due to thick stratum corneum (SC) layer that can retain water and make the hydration level for the palm of the hand skin substantially higher in wet state compared with normal state [17].

## 4.3 Reflectance for porcine skin samples

The mean and the standard deviation of the reflectance measurements performed on porcine skin samples over the frequency band (80-100) GHz are illustrated in Figure 5; the mean reflectance values of the porcine skin samples were measured experimentally using the methodology described in section 3.5. The measurements were made on four fresh porcine skin samples taken from the back region of the same animal. The measurements were repeated five times on each sample.



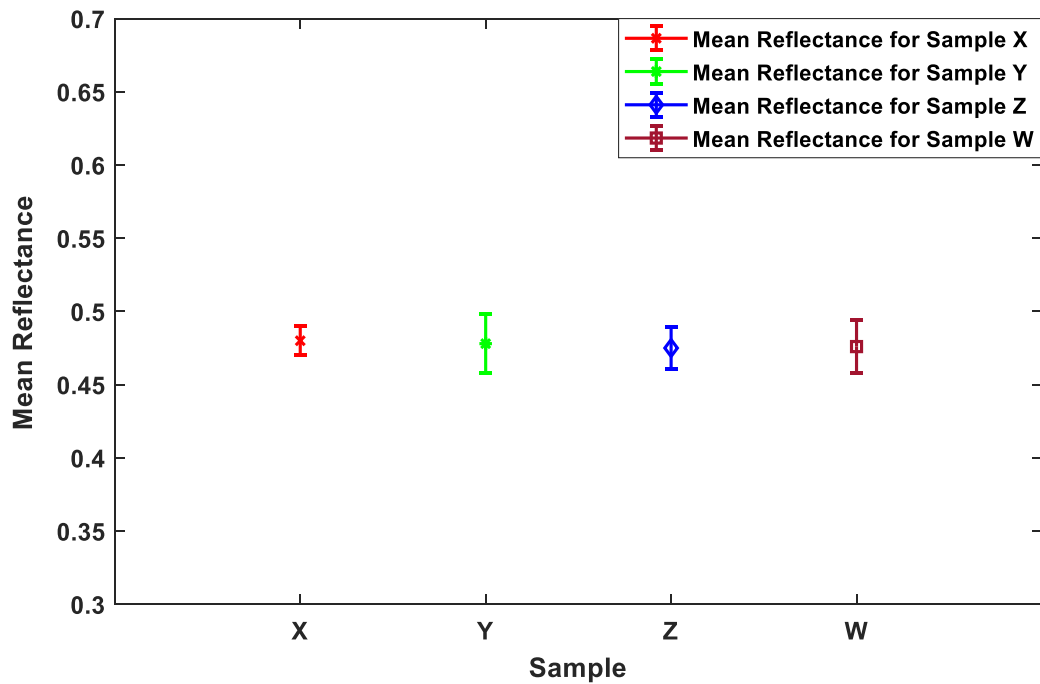

**Figure 5. Mean reflectance values and standard deviation bars for porcine skin samples X, Y, Z, and W.**

Experimental measurements in Figure 5 indicate that the mean reflectance value of the samples X, Y, Z, and W is  $\sim 0.48$  with experimental measurements uncertainty of  $\pm 0.005$ . The standard deviations of the samples were calculated to be in the range of  $\sim 0.01$  to  $\sim 0.02$ . Considering the standard deviation gives mean reflectance values of porcine skin samples in the range of (0.46-0.50). Comparing the mean reflectance range of porcine skin samples with the range obtained from human skin indicates that the mean reflectance range of porcine skin samples is within the mean reflectance range of the palm of the hand skin and the dorsal surface skin of the sample of 60 healthy participants (see table 1). This indicates that porcine skin can be used for mimicking the signature of the thick regions of the human skin.

#### **4.4 Reflectance for porcine skin before and after the application of water and cream**

The mean reflectance values for porcine skin samples before and after the application of cream and water were measured experimentally using methodology described in section 3.5. The methodology was applied on samples X, Y, Z, and W as illustrated in Figure 6.

Experimental measurements in Figure 6 indicate that there is a well define contrast in the mean reflectance values of the skin before and after the application of water and cream. The differences in the mean reflectance values of the skin before and after the application of cream and water are ranging from  $\sim 0.04$  to  $\sim 0.19$ . The mean reflectance values of the porcine skin samples after the application of Savlon cream (that includes of Cetostearyl alcohol, liquid paraffin, perfume, and purified water) and Flamazine cream (that includes of Silver Sulfadiazine, cetyl alcohol, liquid paraffin, and purified water) are higher than that of Sudocream (that includes of purified water, liquid paraffin, and paraffin wax). These differences are due to the dielectric properties of the cream, the percentage of water content in the cream, the interaction of the porcine skin samples with different types of creams, and the ingredients that vary from cream to cream. These differences indicate that radiometric sensitivity is sufficient to sense and detect variation in the skin water content and hydration level. Experimental measurements for ex-vivo porcine skin samples before and after the application of water having similar trends to that obtained from human skin (see Figure 4) indicating that ex-vivo porcine skin can be used for modeling the signature of the human skin over the millimetre wave band.

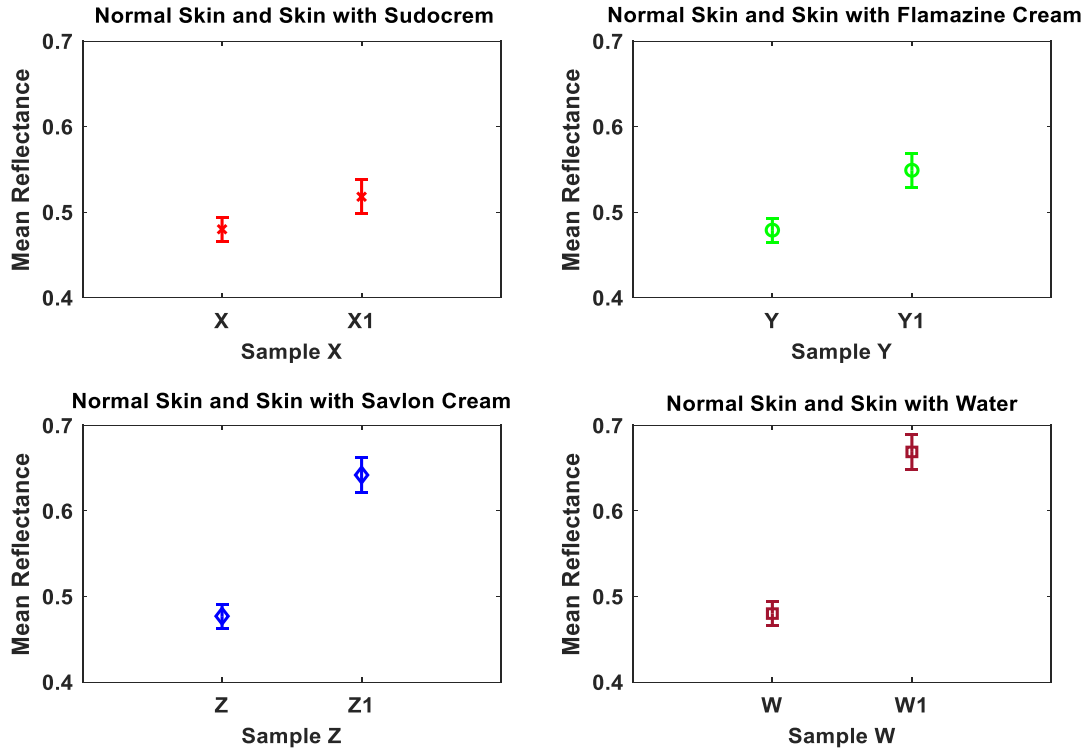

Figure 6: Mean Reflectance values and standard deviation bars for porcine skin samples before and after the application of cream and water. Samples X, Y, Z, and W represent normal skin, X1: represents skin with Sudocrem, Y1: represents skin with Flamazine cream, Z1: represents skin with Savlon cream, and W1: represents skin with water.

## 5. CONCLUSIONS

The measurements presented in this paper show a strong correlation between the skin reflectance, the skin thickness and the hydration level of the skin for both human skin and ex-vivo porcine skin samples. The measurements conducted on four porcine skin samples from the back regions of the animal over the band 80 GHz to 100 GHz indicate that the mean reflectance values of the porcine skin are in the range of 0.46 to 0.50. The measurements of human skin reflectance conducted on the palm of the hand region and dorsal surface of forearm for a sample of 60 healthy participants in Table 1 indicate that the mean reflectance values of the human skin for these two regions are ranging from 0.4611 to 0.6487. This means that the mean reflectance values of the porcine skin samples (back region) are within the range of human skin reflectance measurements of the palm of hand region and the dorsal surface of forearm (thick regions). These results confirm that porcine skin is a good phantom model for the human skin. Measurements of porcine skin samples before and after the applications of cream and water indicate that water and cream increase the mean reflectance values of the samples in the range of 0.04 to 0.19. This is likely to be increased with the amount of water and cream layer placed on the sample and it also depends on the dielectric properties of the cream and the thickness of the cream layer. This indicates that there is a strong correlation between the reflectance of the skin and the skin water content and the hydration level of the skin. These results are strongly supported by the simulation results of the half space model [8] and indicate that radiometry might be useful for non-invasive diagnosis of skin disease where the disease alter the water content of the skin.

## 6. FUTURE WORK

As a plan for future work it is recommended that reflectance measurements be made on different regions of the human body such as the legs, the back, the chest, the belly, the arms, and the foots for healthy participants and participants having skin conditions such as thermal burn, eczema, malignancy, and psoriasis. This will demonstrate the potential and

the measured signatures of the diseased skin can be compared with the healthy skin. Based on the results presented in this paper, it is recommended that further measurements be made on larger and more varied groups of porcine skin samples to investigate possible similarities and differences between the signatures of human skin and porcine skin. This might be done at a range of frequencies (35 GHz, 60 GHz, 90 GHz, and 120 GHz) the lower frequencies offering greater penetration into the skin and underlying tissue.

## REFERENCES

- [1] Owda, A. Y., Salmon, N., Rezgui, N.-D. and Shylo, S., "Millimetre wave radiometers for medical diagnostics of human skin," in *IEEE Sensors 2017*, Glasgow (2017).
- [2] Owda, A. Y., Salmon, N. and Rezgui, N.-D., "Electromagnetic Signatures of Human Skin in the Millimeter Wave Band 80–100 GHz," *Progress In Electromagnetics Research B. Papers* 80, 79-99 (2018).
- [3] Owda, A.Y., Rezgui, N.-D. and Salmon, N., "Signatures of human skin in the millimeter wave band (80-100) GHz, " in *SPIE Europe Security+Defence, Millimetre Wave and Terahertz Sensors and Technology X*, Warsaw (2017).
- [4] Owda, A.Y. and Salmon, N., " Variation in the electromagnetic signatures of the human skin with physical activity and hydration level of the skin," in *SPIE Europe Security+Defence, Millimetre Wave and Terahertz Sensors and Technology XII*, France (2019).
- [5] Harmer, S. W., Shylo, S., Shah, M., Bowring, N. J. and Owda, A. Y., "On the feasibility of assessing burn wound healing without removal of dressings using radiometric millimetre-wave sensing," *Progress In Electromagnetics Research M. Papers* 45, 173-183 (2016).
- [6] Owda, A.Y., Owda, M. and Rezgui, N.-D., "Synthetic Aperture Radar Imaging for Burn Wounds Diagnostics," *Sensors. Papers* 20, 1-17 (2020).
- [7] Owda, A.Y., Salmon, N.A., Shylo, S. and Owda, M., "Assessment of Bandaged Burn Wounds Using Porcine Skin and Millimetric Radiometry," *Sensors. Papers* 19, 1-18 (2019).
- [8] Owda, A. Y., Salmon, N., Harmer, S. W., Shylo, S., Bowring, N. J., Rezgu, N. D. and Shah, M., "Millimeter-wave emissivity as a metric for the non-contact diagnosis of human skin conditions," *Bioelectromagnetics. Papers* 38, 559-569 (2017).
- [9] Owda, A.Y., Salmon, N.A., Casson, A. and Owda, M., "The Reflectance of Human Skin in the Millimeter-Wave Band," *Sensors. Papers* 20, 1-22 (2020).
- [10] Rees, W. G., [Physical Principles of remote sensing], 3rd ed., Cambridge University Press Publisher, New York (2013).
- [11] Salmon, N. A., Borrill, J. R. and Gleed, D. G., "Absolute temperature stability of passive imaging radiometers, " in *SPIE Passive Millimeter-Wave Imaging Technology*, Orlando (1997).
- [12] Pozar, D. M., [Microwave Engineering], 4th ed., John Wiley & Sons Publisher, Hoboken (2011).
- [13] Andrews, C. J., Kempf, M., Kimble, R. and Cuttle, L., "Development of a Consistent and Reproducible Porcine Scald Burn Model", *PLoS ONE. Papers* 11, 1-18 (2016).
- [14] Gray, H., [Anatomy of the Human Body], Lea & Febiger Publisher, Philadelphia (1981).
- [15] Giacomoni, P. U., Mammone, T. and Teri, M., "Gender-linked differences in human skin," *Journal of Dermatological Science. Papers* 55, 144-149 (2009).
- [16] Ibrani, M., Ahma, L. and Hamiti, E., [The Age-Dependence of Microwave Dielectric Parameters of Biological Tissues]. InTech Publisher, London (2012).
- [17] Alekseev, S. I., Szabo, I. and Ziskin, M. C., "Millimeter wave reflectivity used for measurement of skin hydration with different moisturizers," *Skin Research and Technology. Papers* 14, 390–396 (2008).