

**Please cite the Published Version**

Jurack, Brigitte (2018) Why bother? Uncertainty, awkwardness and bravado in the sculptural representation of youth. Doctoral thesis (PhD), Manchester Metropolitan University.

Downloaded from: <https://e-space.mmu.ac.uk/621435/>

Usage rights:  Creative Commons: Attribution-Noncommercial-No Derivative Works 4.0

**Enquiries:**

If you have questions about this document, contact [openresearch@mmu.ac.uk](mailto:openresearch@mmu.ac.uk). Please include the URL of the record in e-space. If you believe that your, or a third party's rights have been compromised through this document please see our Take Down policy (available from <https://www.mmu.ac.uk/library/using-the-library/policies-and-guidelines>)

WHY BOTHER? UNCERTAINTY, AWKWARDNESS AND BRAVADO  
IN THE SCULPTURAL REPRESENTATION OF YOUTH

BRIGITTE JURACK

PhD 2017



WHY BOTHER? UNCERTAINTY, AWKWARDNESS AND BRAVADO  
IN THE SCULPTURAL REPRESENTATION OF YOUTH

Brigitte Jurack

A thesis submitted in partial fulfilment of the requirements  
of the  
Manchester Metropolitan University for the degree of  
Doctor of Philosophy

Manchester School of Art  
Manchester Metropolitan University

2017

# Part 1

## Representation of youth through sculpture

Brigitte Jurack









Plate 1 *Just wait for me* (2012-13)





Plate 2 *Untitled plastiline figures, British School of Athens (2011)*





Plate 3 *Untitled plasteline figures, British School of Athens (2011)*





Plate 4 *Untitled plastiline figures, British School of Athens (2011)*



Plate 5 *Untitled plasteline figures, British School of Athens (2011)*



Plate 6 *Untitled plasteline figures, British School of Athens (2011)*



Plate 7 *Untitled plasteline figures, British School of Athens (2011)*



Plate 8 *Untitled plasteline figures, British School of Athens (2011)*





Plate 9 *Untitled plasteline figures, British School of Athens (2011)*



Plate 10 *Untitled plasteline figures, British School of Athens (2011)*



Plate 11 *Untitled plasteline figures, British School of Athens (2011)*





Plate 12 *Untitled plasteline figures, British School of Athens (2011)*



Plate 13 *Untitled plasteline figures, British School of Athens (2011)*

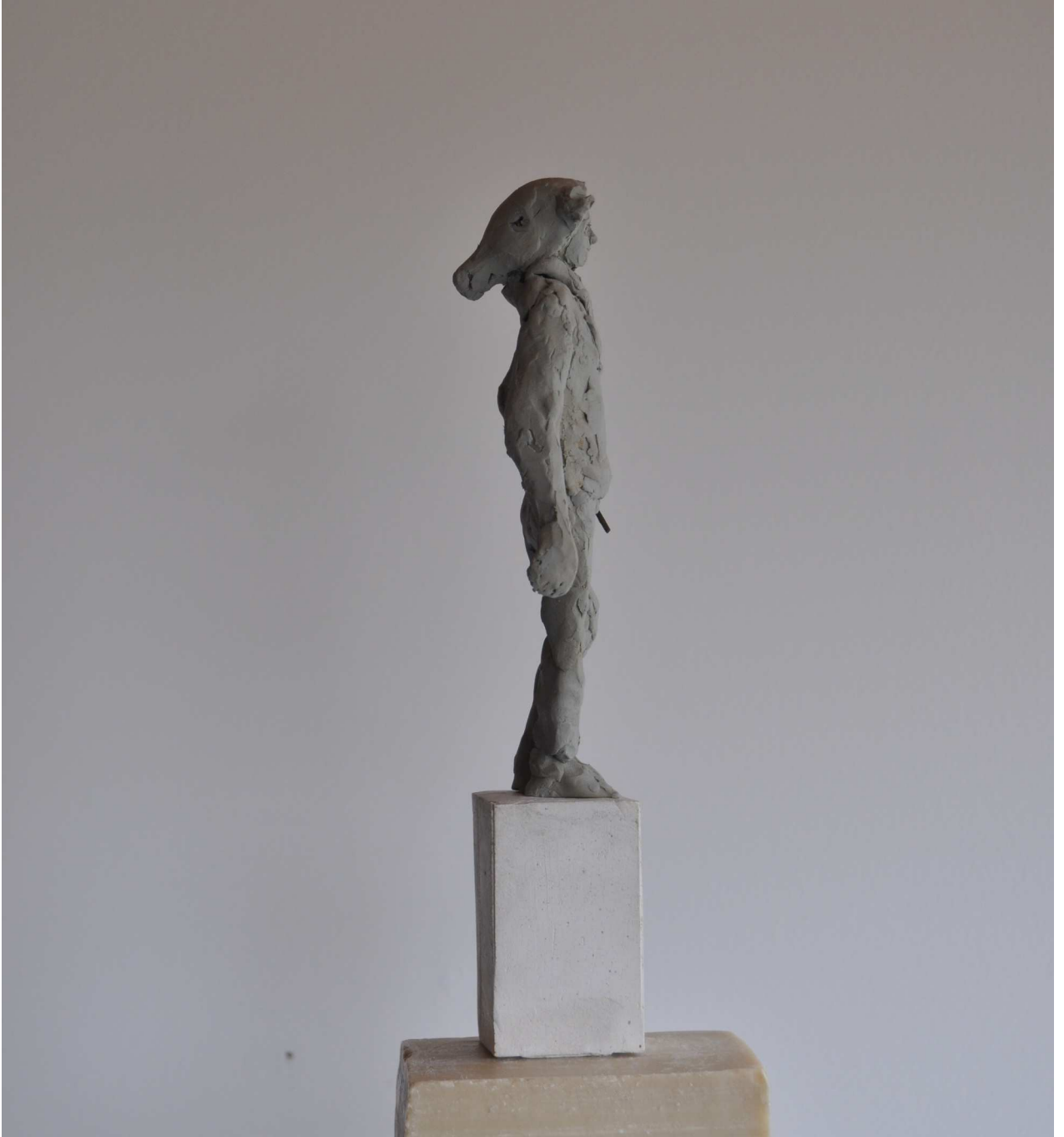

Plate 14 *Untitled plasteline figures, British School of Athens (2011)*



Plate 15 *Untitled plasteline figures, British School of Athens (2011)*



Plate 16 *Untitled plasteline figures, British School of Athens (2011)*



Plate 17 *Untitled plasteline figures, Oxtou (2011)*





Plate 18 *Untitled plasteline figures, Oxton (2011)*



Plate 19 *Untitled plasteline figures*, Oxtan (2011)





Plate 20 *Untitled plasteline figures, Oxton (2011)*



Plate 21 *Untitled plasteline figures, Oxton (2011)*



Plate 22 *Untitled plasteline figures, Oxton (2011)*



Plate 23 *Untitled plasteline figures, Oxtou (2011)*



Plate 24 *Untitled plasteline figures, Oxtan (2011)*







Plate 25 Work in progress *Waiting* (2009)



Plate 26 Work in progress *Waiting* (2009)





Plate 27 Work in progress *Waiting* (2009)





Plate 28 *Waiting* (2009)



Plate 29 *Waiting* (2009)





Plate 30 *Waiting* (2009)







Plate 31 *Untitled plasteline figures, Oxton (2011)*

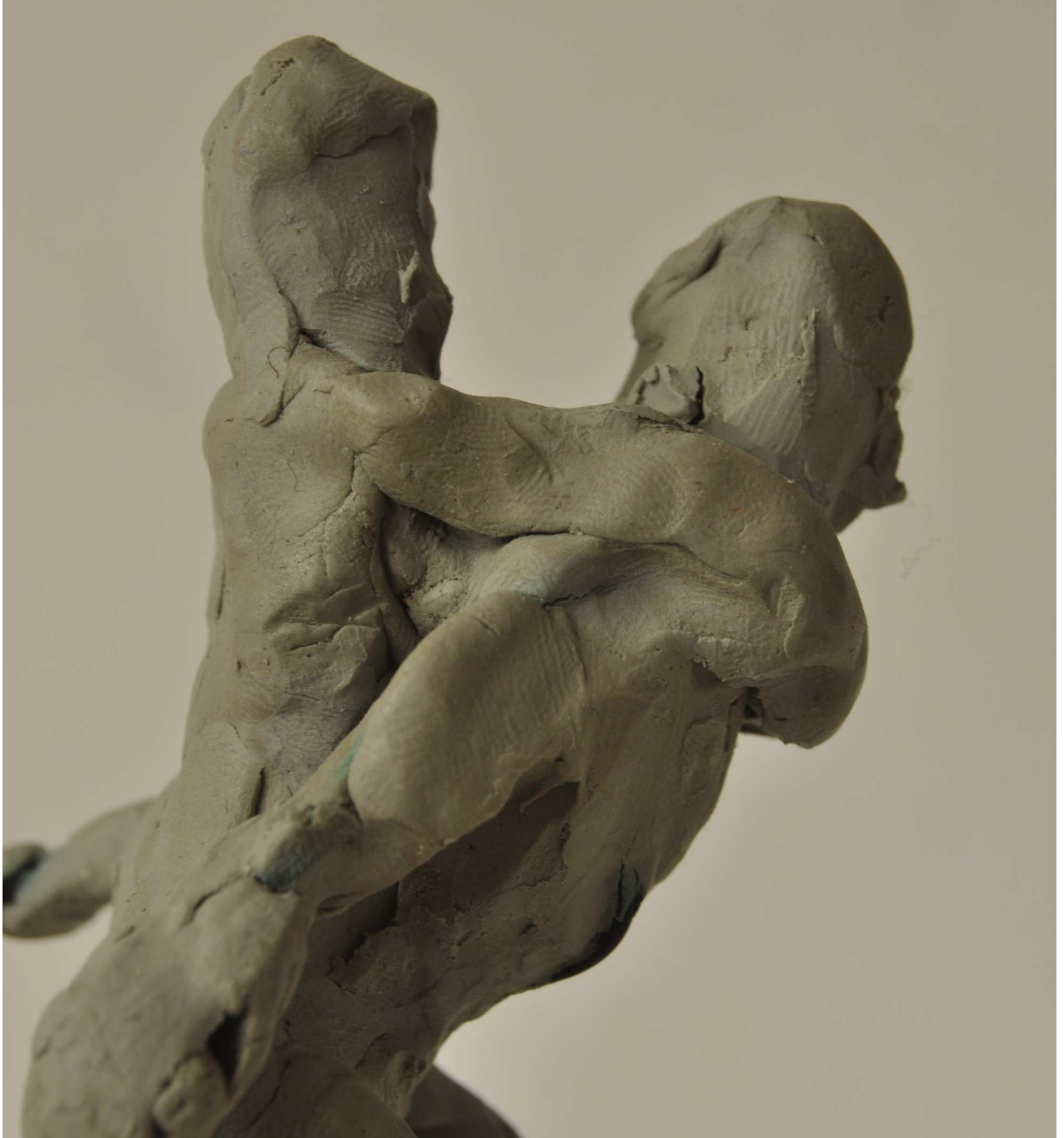

Plate 32 *Untitled plasteline figures, Oxtou (2011)*



Plate 33 *Untitled plasteline figures, Oxton (2011)*



Plate 34 Work in progress *Just wait for me* (2012)





Plate 35 Work in progress *Just wait for me* (2012)



Plate 36 Work in progress *Just wait for me* (2012)





Plate 37 Work in progress *Just wait for me* (2012)



Plate 38 Work in progress *Just wait for me* (2012)





Plate 39 Work in progress *Just wait for me* (2012)





Plate 40 Work in progress *Just wait for me* (2012)





Plate 41 Work in progress *Just wait for me* (2012)



Plate 42 Study for *Just wait for me* (2012)



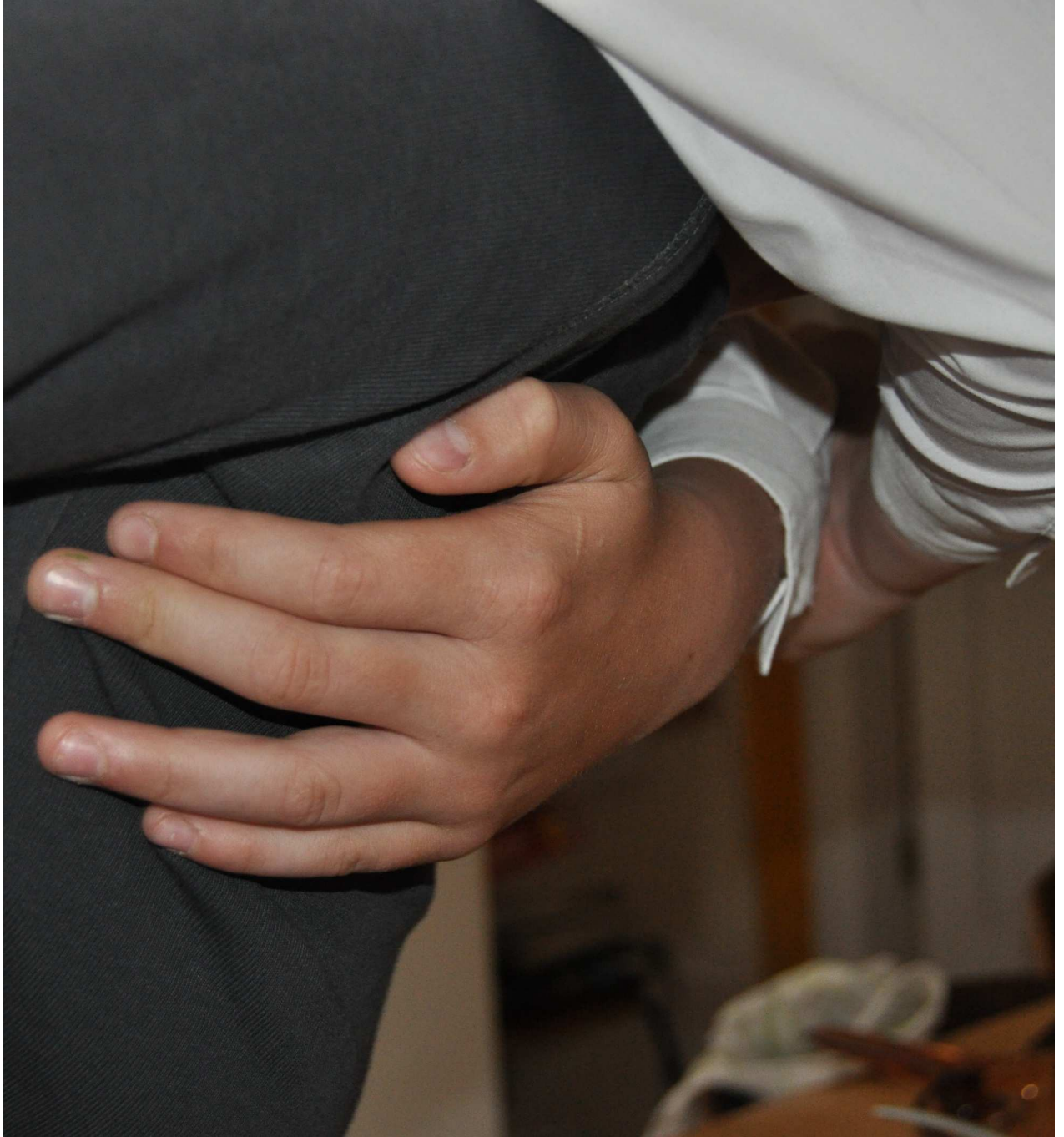

Plate 43 Study for *Just wait for me* (2012)

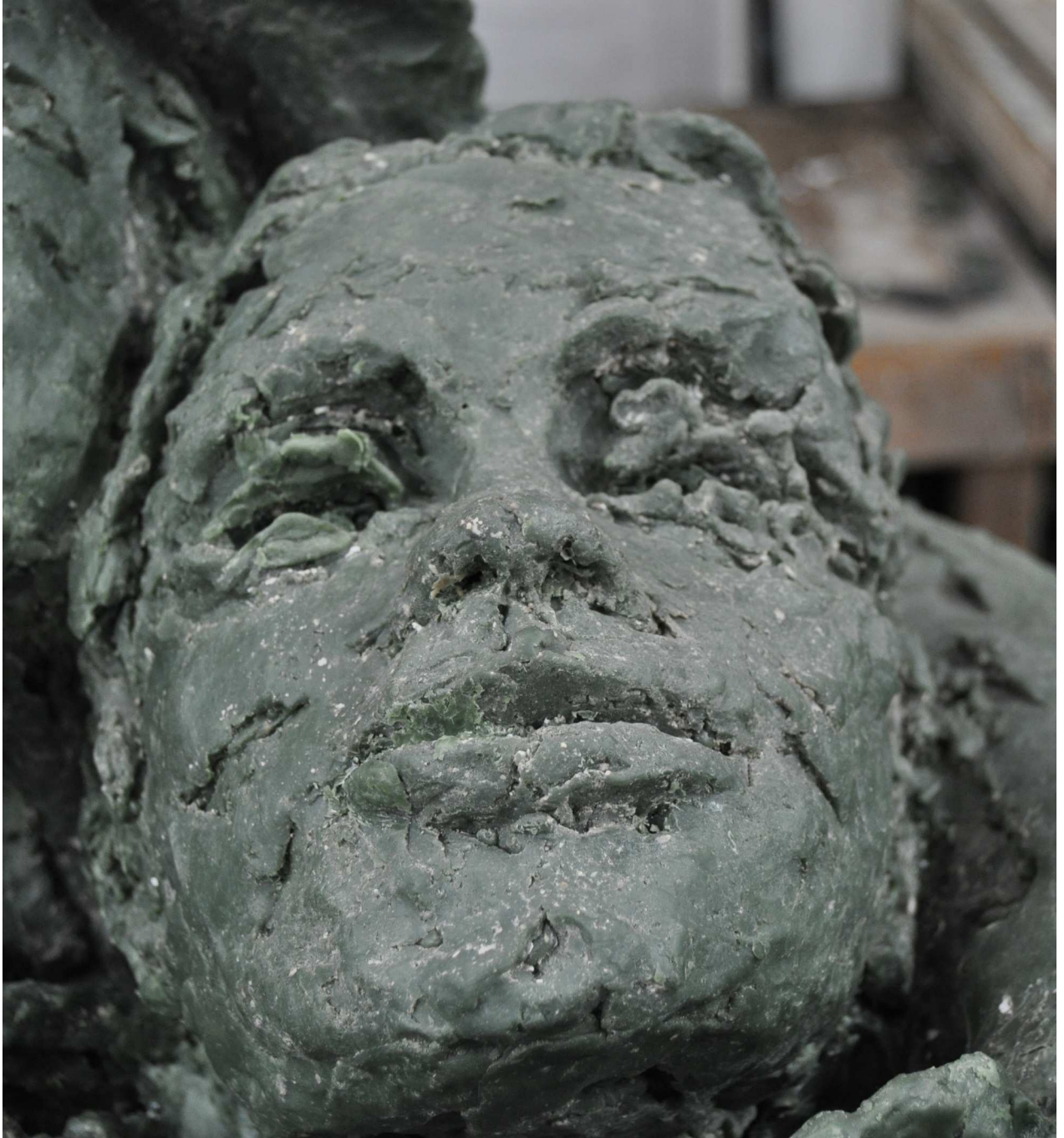

Plate 44 Work in progress *Just wait for me* (2012-13)



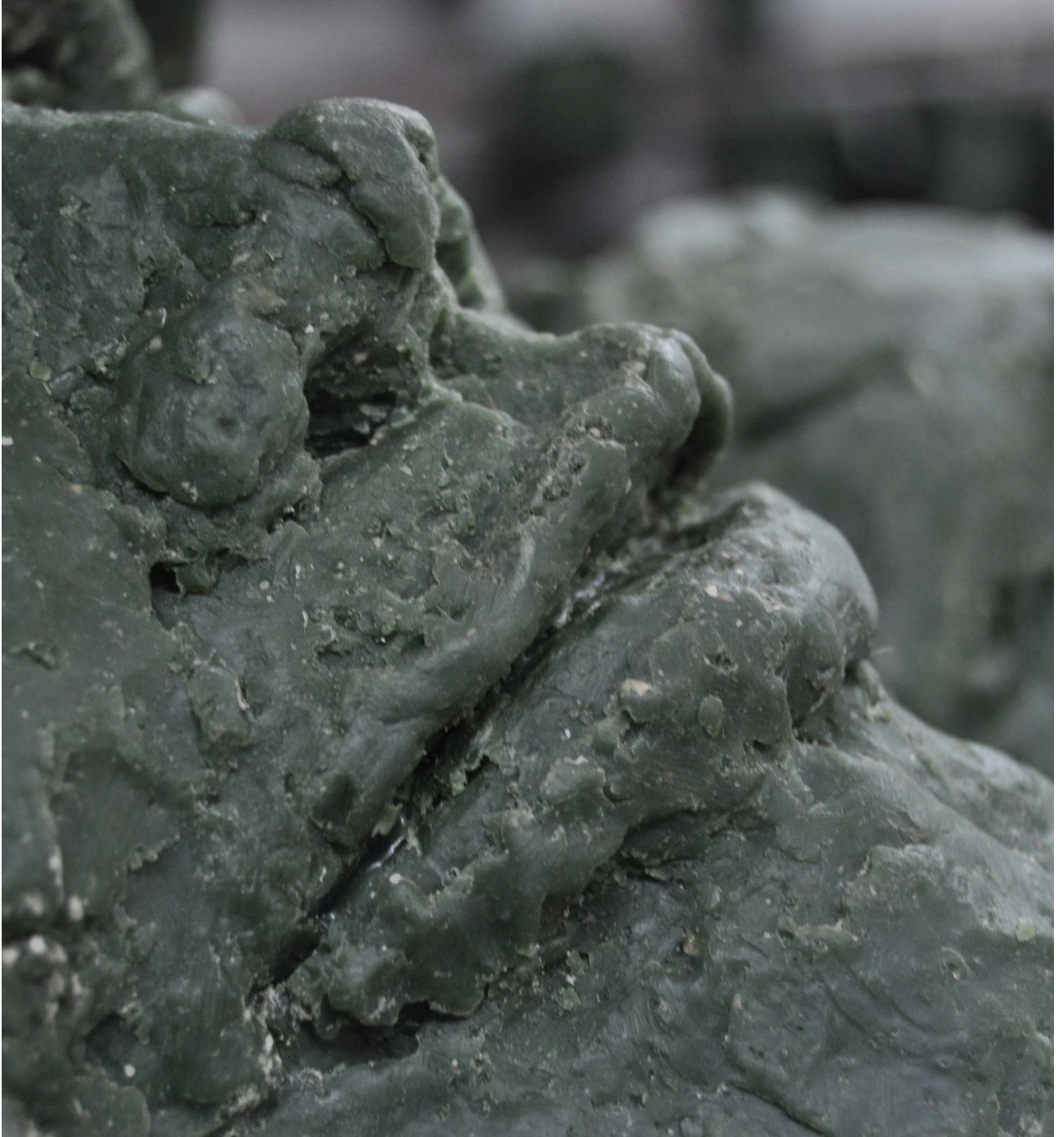

Plate 45 Work in progress *Just wait for me* (2012-13)



Plate 46 Work in progress *Just wait for me* (2012-13)



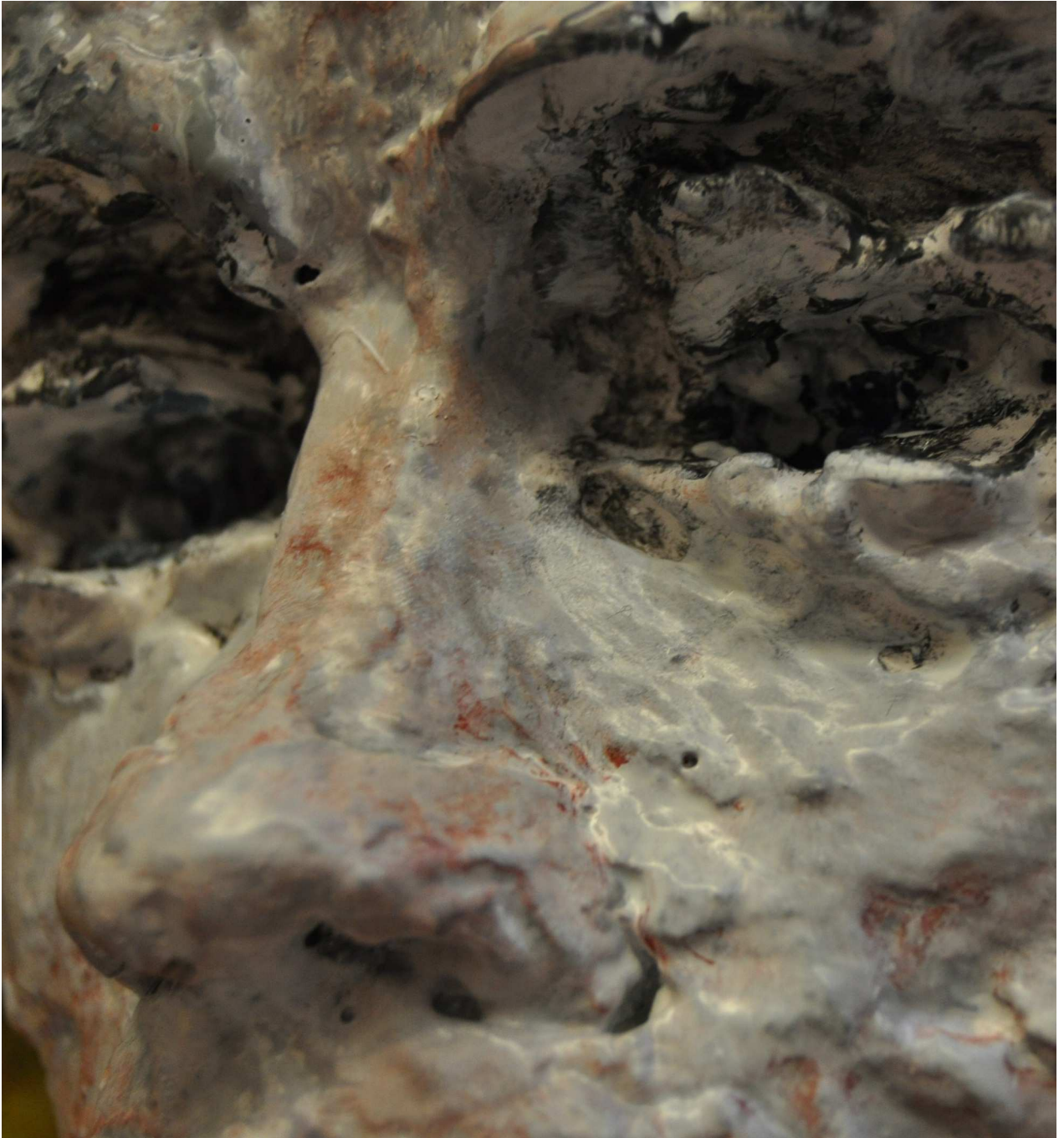

Plate 47 Work in progress *Just wait for me* (2012-13)



Plate 48 Work in progress *Just wait for me* (2012-13)





Plate 49 Work in progress *Just wait for me* (2012-13)



Plate 50 Work in progress *Just wait for me* (2012-13)





Plate 51 Work in progress *Just wait for me* (2012-13)





Plate 52 Work in progress *Just wait for me* (2012-13)





Plate 53 Work in progress *Just wait for me* (2012-13)





Plate 54 Version 2 of *Boy with mouse* (2009), with *Girl with fire* (2011)



Plate 55 Version 1 of *Boy with mouse* (2009)





Plate 56 Version 1 of *Boy with mouse* (2009)



Plate 57 Version 4 of *Boy with mouse* (2014)



Plate 58 Version 4 of *Boy with mouse* (2014)





Plate 59 *Boy with parasol* (2009)





Plate 60 *Boy with parasol* (2009)

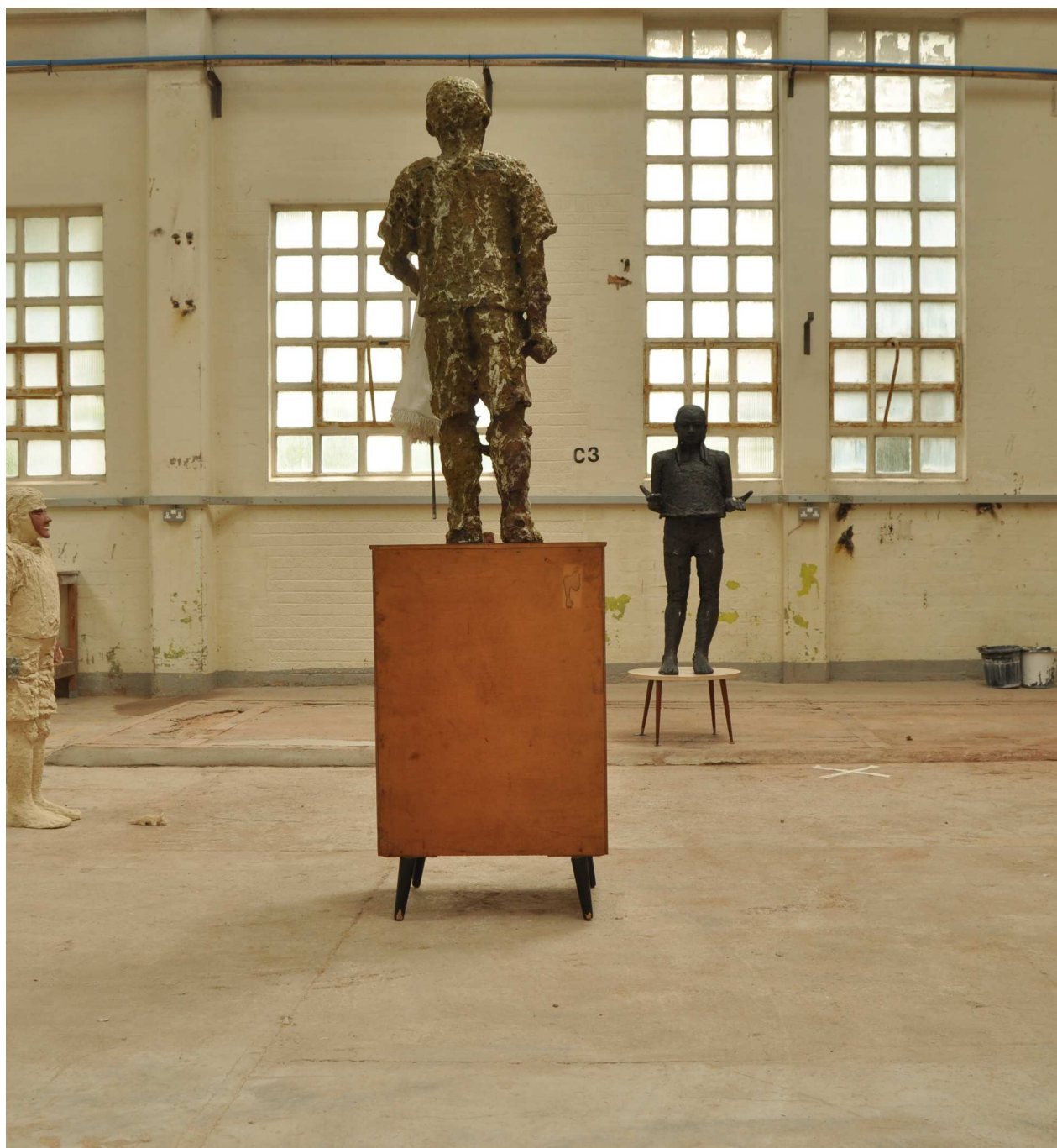

Plate 61 *Boy with mouse* (2009), *Boy with parasol* (2009) and *Girl with fire* (2011)

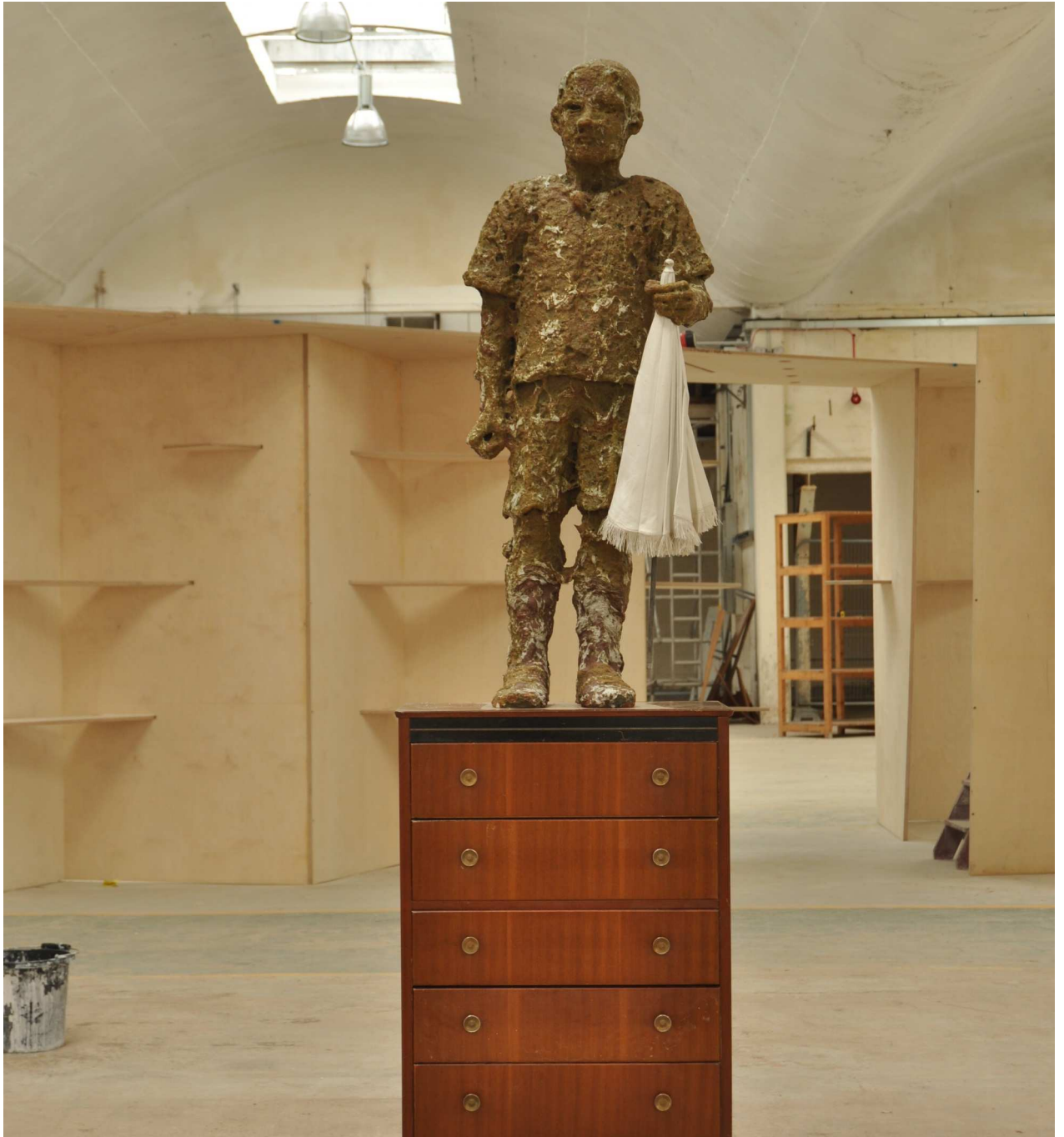

Plate 62 *Boy with parasol* (2009)







Plate 63 *Boy with parasol* (2009)



Plate 64 *Girl with fire* (2011)



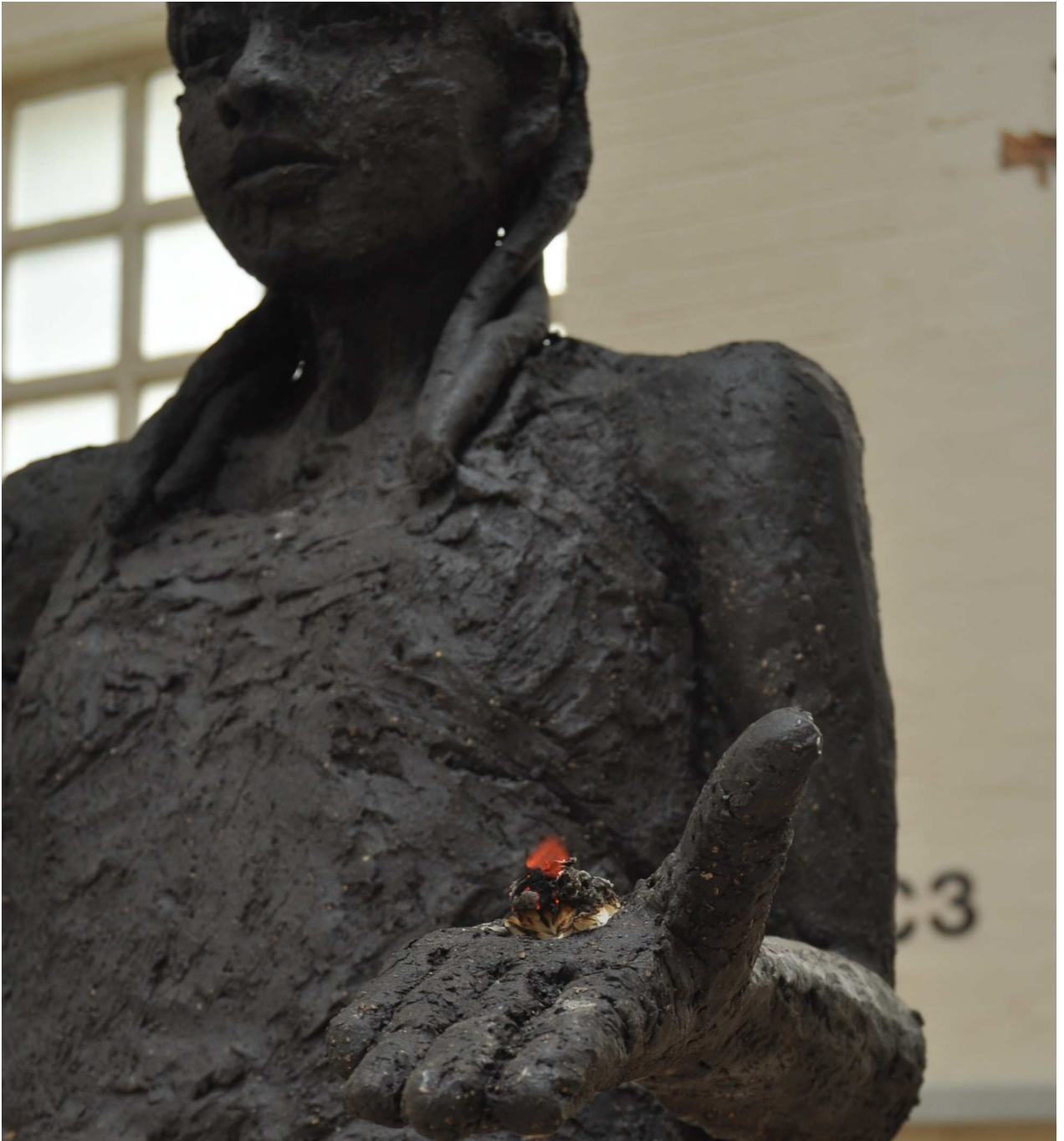

Plate 65 *Girl with fire* (2011)





Plate 66 Study for *Monument for Damian* (2008)





Plate 67 Study for *Monument for Damian* (2008)



Plate 68 Work in progress *Monument for Damian* (2008)



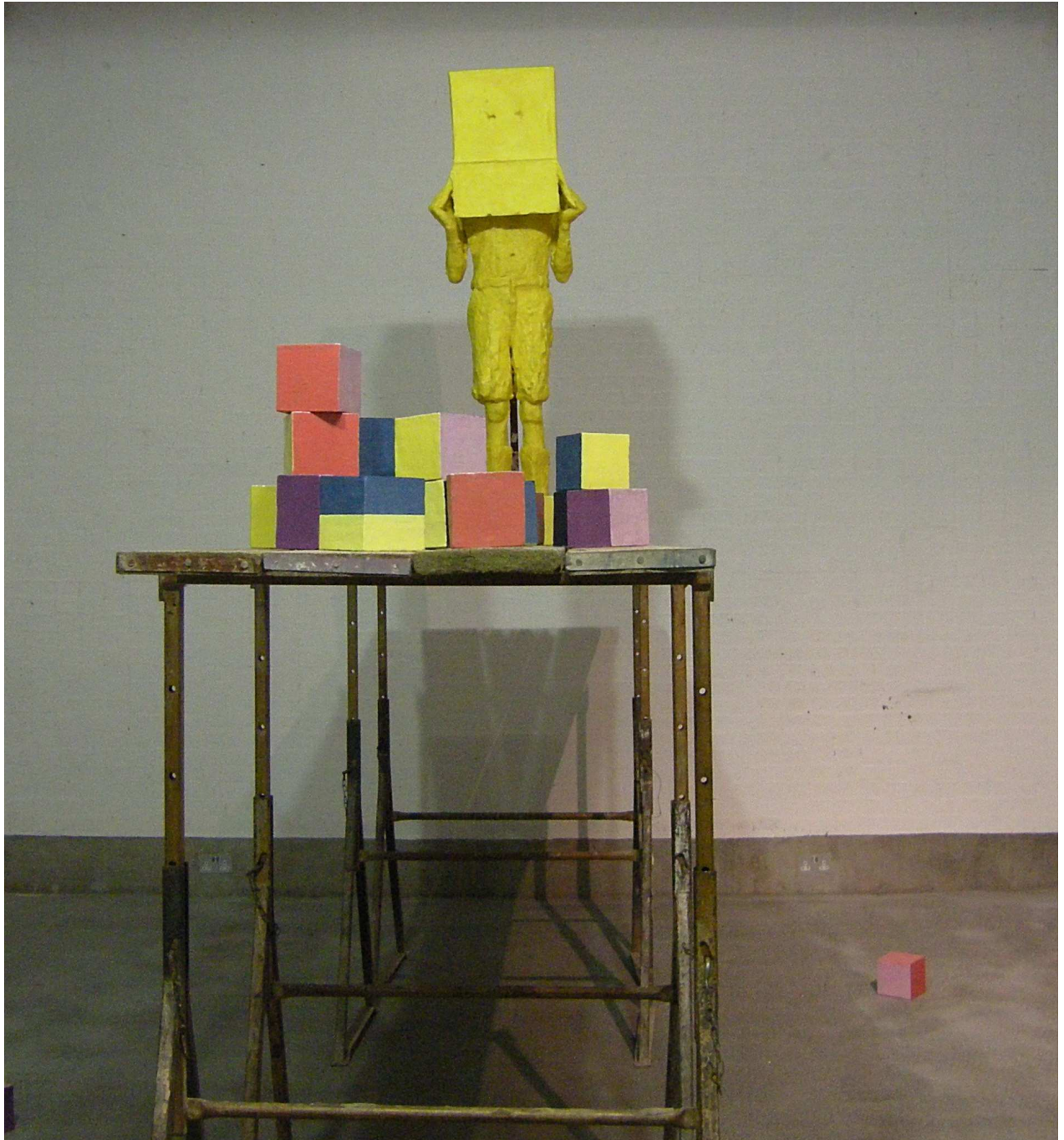

Plate 69 *Monument for Damian* (2008)





Plate 70 *Monument for Damian* (2008)



Plate 71 *Monument for Damian* (2008)



Plate 72 *Monument for Damian* (2008)





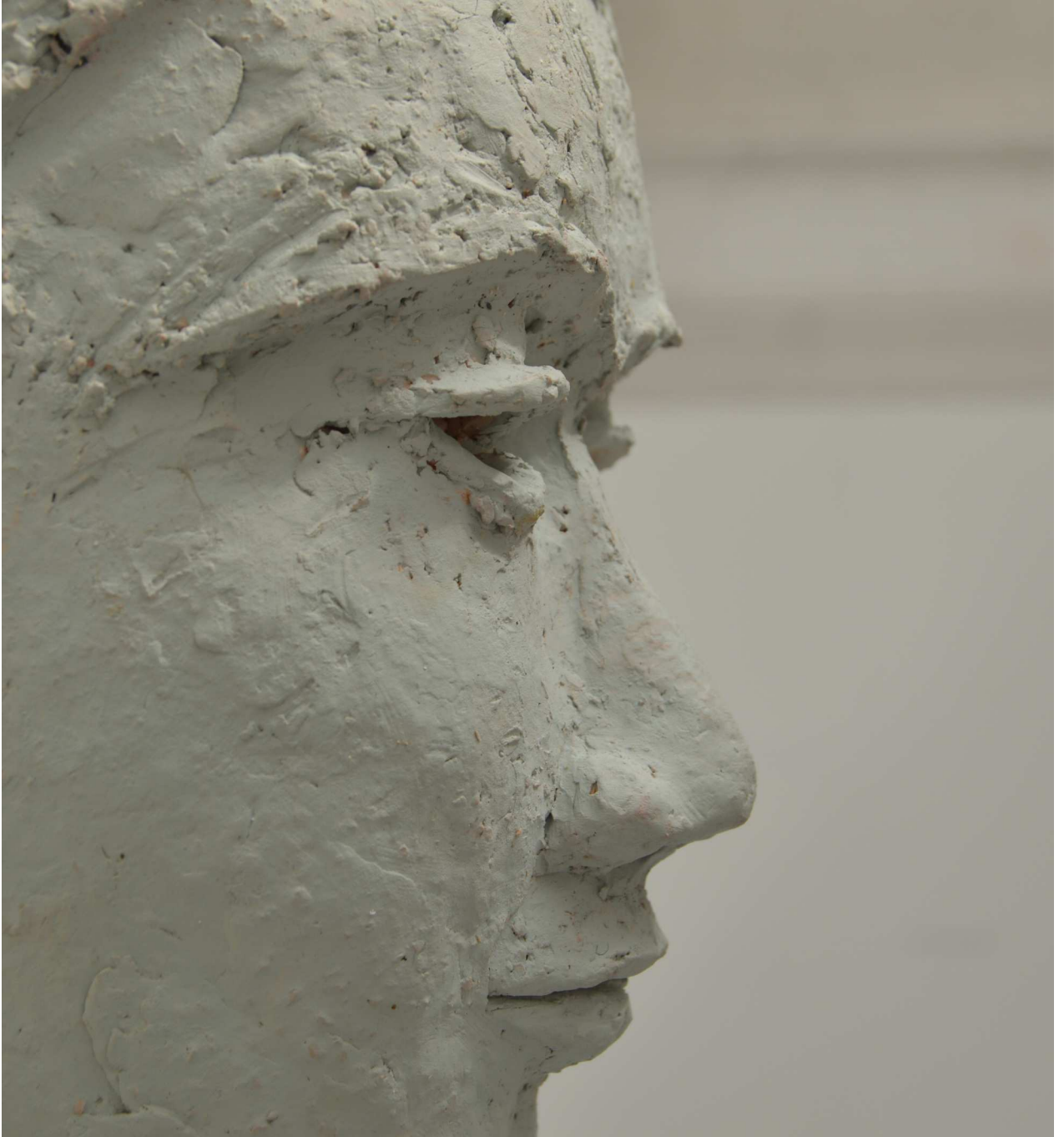

Plate 73 *Dunno* (2016)



Plate 74 *Dunno* (2016)





Plate 75 *Dunno* (2016)



Plate 76 *Dunno* (2016)



Plate 77 *Dunno* (2016)





Plate 78 *Dunno* (2016)



Plate 79 *Dunno* (2016)







Plate 80 *Boy with jacket* (2002)



Plate 81 *Boy with jacket* (2002)



Plate 82 *Boy with jacket* (2002)







Plate 83 Study for *Sleeping Beauty* (2014)



Plate 84 *Sleeping Beauty* (2015)



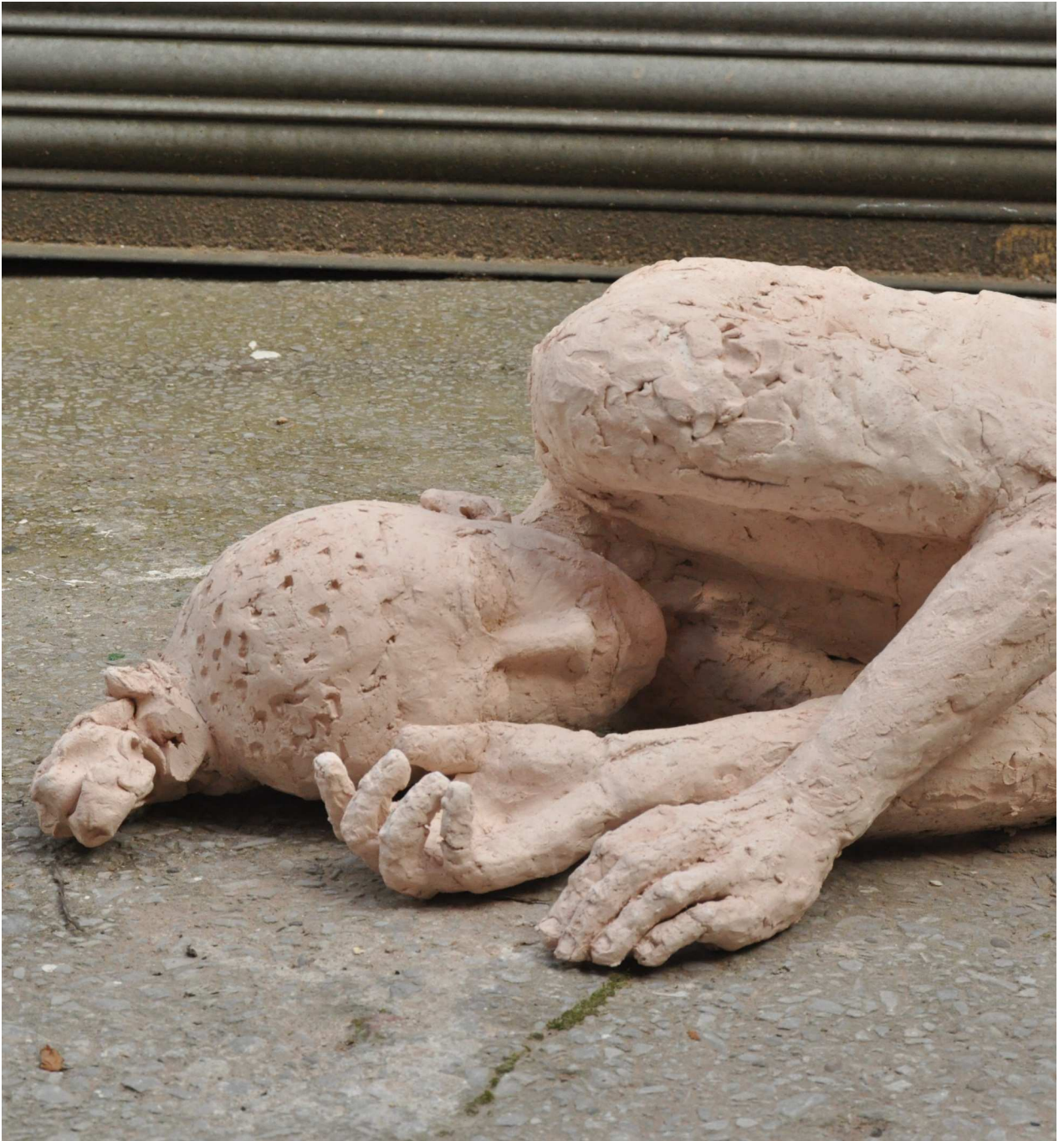

Plate 85 *Sleeping Beauty* (2015)

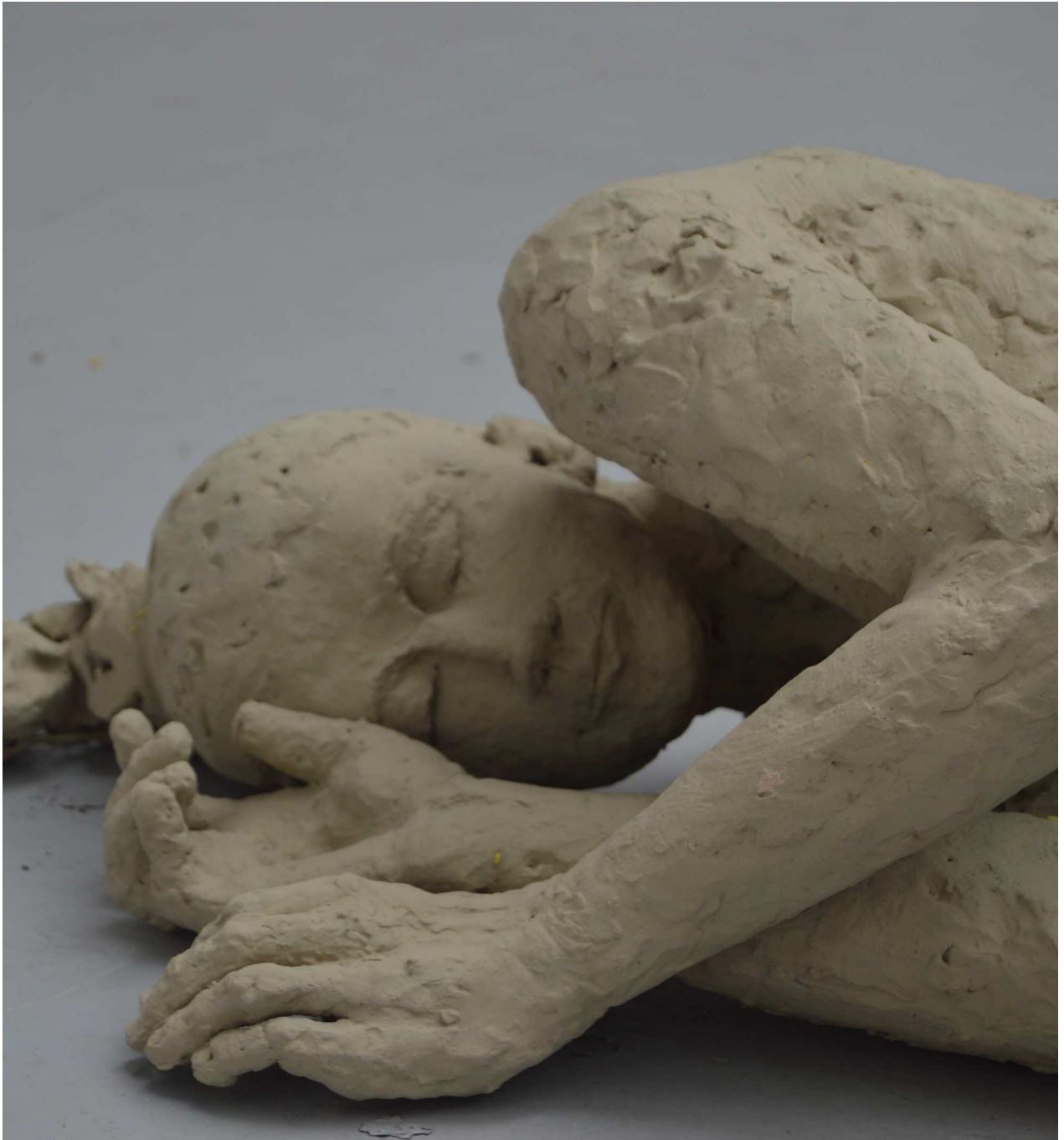

Plate 86 *Sleeping Beauty* (2015)



Plate 87 *Sleeping Beauty* (2015)





Plate 88 *Sleeping Beauty* (2015)



Plate 89 *Sleeping Beauty* (2015)







Plate 90 *Sleeping Beauty* (2015)





Plate 91 *If only* (2016)





Plate 92 *If only* (2016)



Plate 93 *If only* (2016)



Plate 94 *If only* (2016)





Plate 95 *If only* (2016)



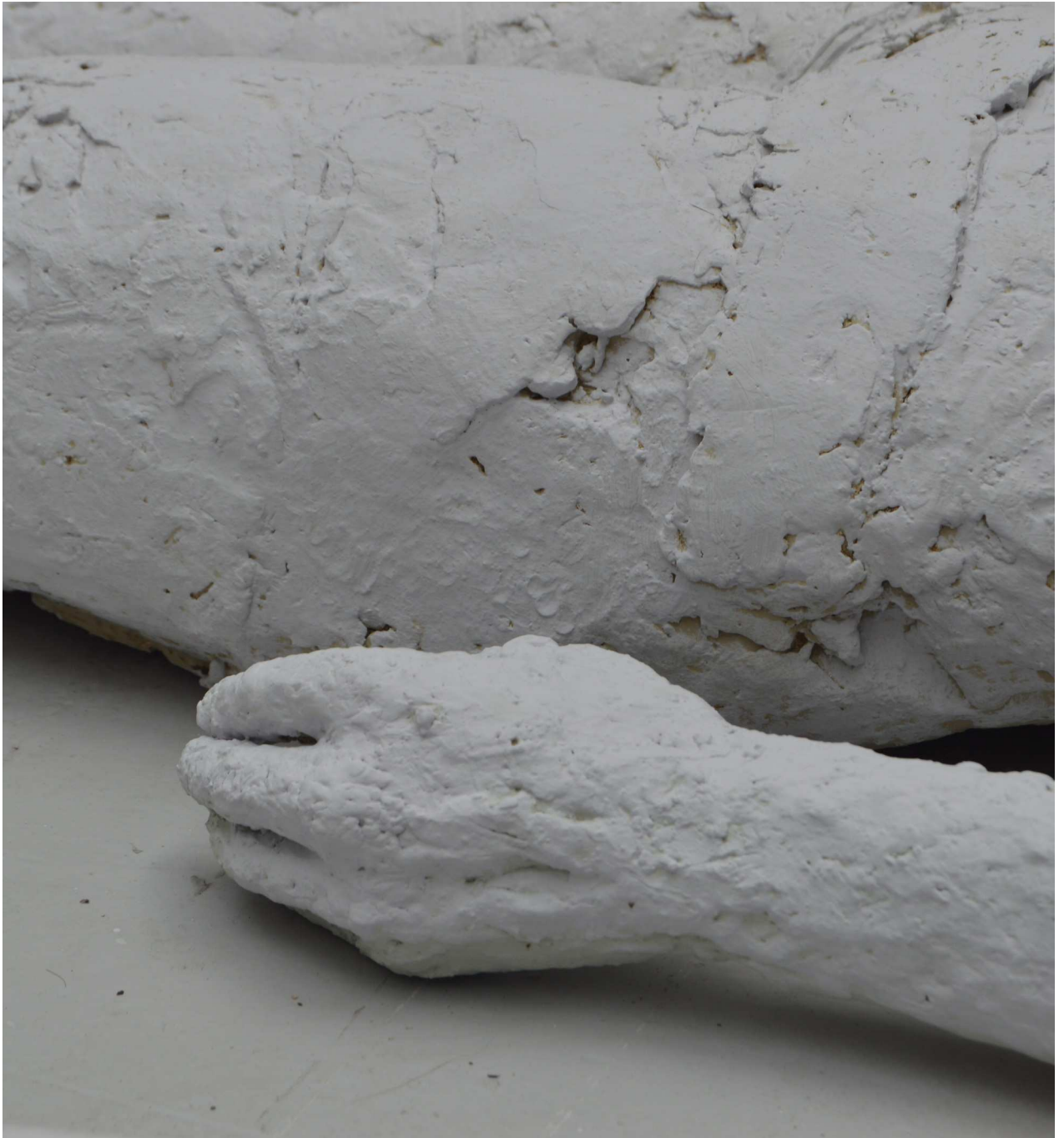

Plate 96 *If only* (2016)



Plate 97 *Boy with knife* (2017)





Plate 98 *Boy with knife* (2017)





Plate 99 Wax figures from Grundy Art Gallery workshops *Just wait for me* (2012)



Plate 100 Park proposals from The Hub workshops *Just wait for me* (2012)





Plate 101 Park proposals from The Hub workshops *Just wait for me* (2012)

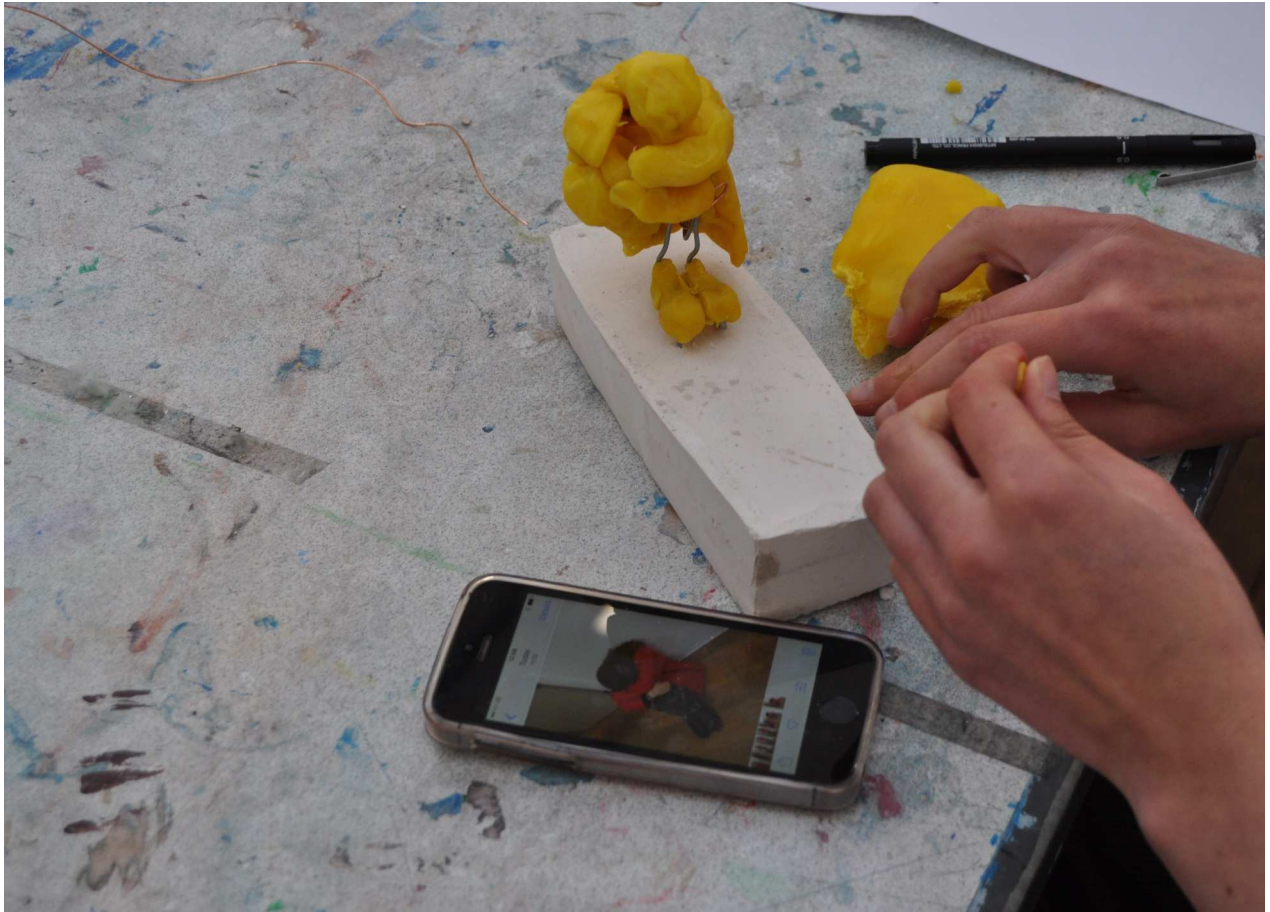

Plate 102 Wax figures from Grundy Art Gallery workshops *Just wait for me* (2012)



Plate 103 Wax figures from Grundy Art Gallery workshops *Just wait for me* (2012)

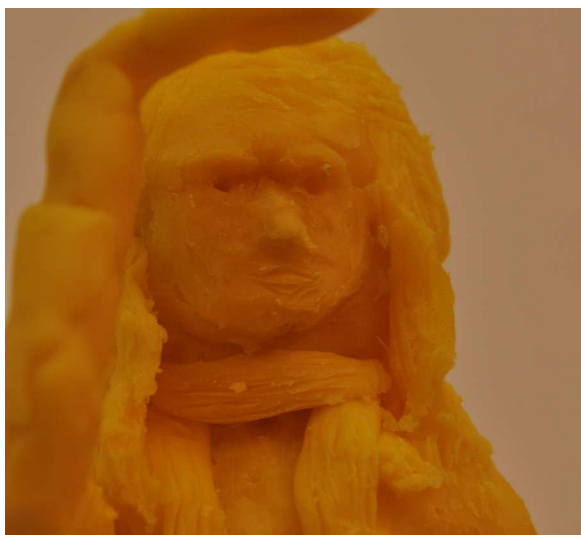

Plate 104 Wax figures from Grundy Art Gallery workshops *Just wait for me* (2012)





Plate 105 Wax figures from Grundy Art Gallery workshops *Just wait for me* (2012)



Plate 106 Wax figures from Grundy Art Gallery workshops *Just wait for me* (2012)



Plate 107 Wax figures from Grundy Art Gallery workshops *Just wait for me* (2012)



Plate 108 Wax figures from Weatherhead High School workshops *Just wait for me* (2012)





Plate 109 Wax figures from Weatherhead High School workshops *Just wait for me* (2012)



Plate 110 Wax figures from Grundy Art Gallery workshops *Just wait for me* (2012)

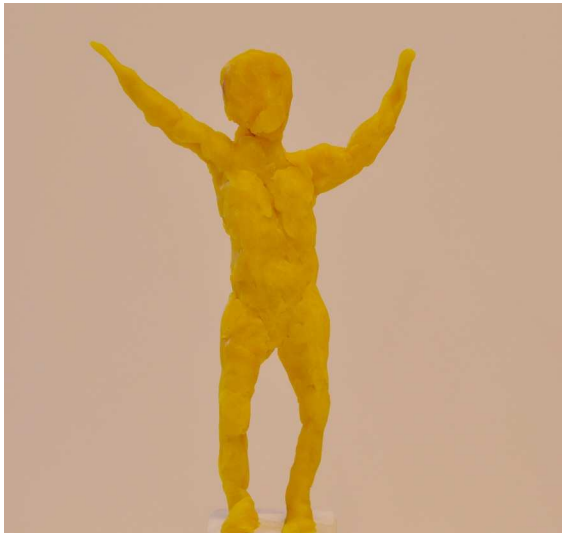

Plate 111 Wax figures from The Hub workshops *Just wait for me* (2012)



Plate 112 Wax figures from The Hub workshops *Just wait for me* (2012)





Plate 113 Wax figures from The Hub workshops *Just wait for me* (2012)



Plate 114 Wax figures from St Mary's Catholic College workshops *Just wait for me* (2012)



Plate 115 Wax figures from St Mary's Catholic College workshops *Just wait for me* (2012)



Plate 116 Wax figures from St Mary's Catholic College workshops *Just wait for me* (2012)





Plate 117 Wax figures from St Mary's Catholic College workshops *Just wait for me* (2012)



Plate 118 Wax figures from The Oldershaw Academy workshops *Just wait for me* (2012)



Plate 119 Wax figures from The Oldershaw Academy workshops *Just wait for me* (2012)





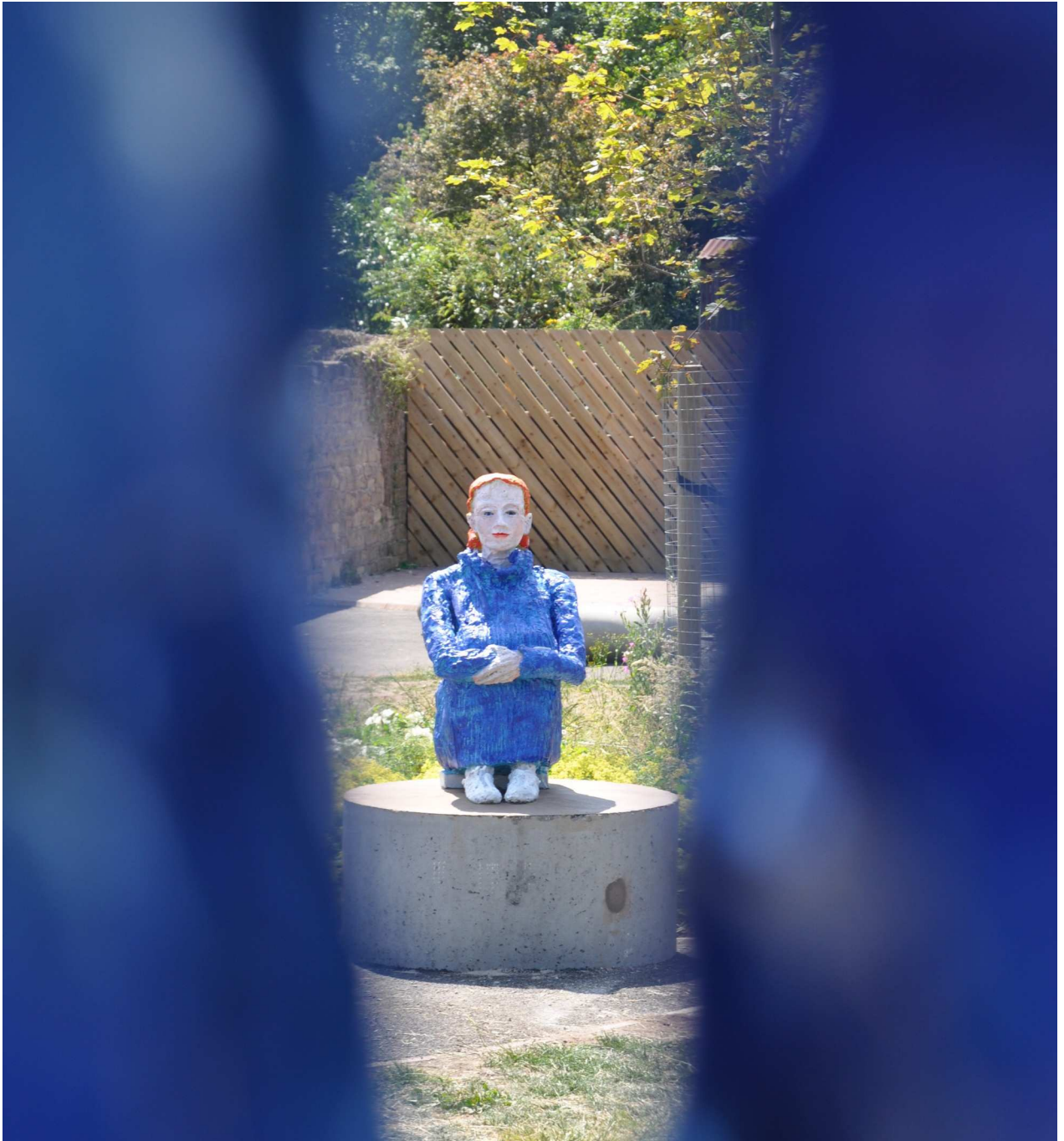

Plate 120 *Just wait for me* (2012-13)



Plate 121 *Just wait for me* (2012-13)





Plate 122 *Just wait for me* (2012-13)





Plate 123 *Just wait for me* (2012-13)





Plate 124 *Just wait for me* (2012-13)



Plate 125 *Just wait for me* (2012-13)





Plate 126 *Just wait for me* (2012-13)



Plate 127 *Just wait for me* (2012-13)





Plate 128 *Just wait for me* (2012-13)





Plate 129 *Just wait for me* (2012-13)









Plate 130 *Just wait for me* (2012-13)



All photographs Brigitte Jurack

2017

Cover image: *Study of hand* (2011)

## Part 2

*Why bother? Uncertainty, awkwardness and bravado in the sculptural representation of youth*

Brigitte Jurack

A thesis submitted in partial fulfilment of the requirements  
of the  
Manchester Metropolitan University for the degree of

Manchester School of Art  
Manchester Metropolitan University

2017





## Abstract

This thesis comprises a study of contemporary sculptural practice employed by the researcher to represent youth, including within socially engaged contexts. 'Youth' is interpreted here as a developmental stage between the ages of 12-20 and the research focuses on the iconography of sculptural representation of youth from Ancient Greece to present day. While existing studies of figurative sculpture recognise affinities with Ancient Greece, none have so far noted recurring motifs within the representation of youth, such as their relationship with site and the way they instantiate, or even demand, a combined studio and community-based practice. Conversely, although studies of socially engaged art analyse the complex relationships between diverse stakeholders, they lack detailed insight into artists' perspectives and practices in relation to specific local settings.

This research seeks to address these gaps, supported by Aby Warburg's findings that significant motifs permeate from Antiquity through to the present, and through the use of documentation and critical analysis of a large number of sculpture and relevant socially engaged practices in Merseyside. This is done in conjunction with the researcher's own creative practice consisting of 15 sculptures, 30 statuettes, a collection of drawings, works produced by young people and the permanent public artwork representing youth, *Just wait for me* (2012-13) in Central Park, Wallasey. All the works address motifs of youth that reflect uncertainty, awkwardness and bravado. The result is to fuse three iconographic motifs with a new hybrid method for 'local' artists working with communities, particularly young people, a local and artist-led approach that remains under-considered in the context of global 'curatorial-matchmaking' of socially engaged practice.

The documentation of and reflection upon the researcher's own sculptural work references and discusses the implications and strategies involved when reflecting on aspects of representation within making and interpretation of sculpture. The combination of the researcher's creative work and written text produces a thesis that demonstrates how key motifs, ur-experiences, the physical studio environment and the local community setting impact upon the sculptural representation of youth, culminating in a new locally engaged site-specific permanent sculpture.

The outcomes, also contributions to knowledge, are:

The portrayal of youth dating back to Ancient Greece is understood across three key motifs, namely the states of rehearsal, self-absorption and vulnerability.

The uses of the double figure as a form of three-dimensional reflection enhances this sculptural representation of youth as uncertain, awkward and being in limbo.

The knowledge of a 'local' artist from a different cultural background, enables the development of a new hybrid method for creating the socially-engaged site-specific permanent sculpture that regards all participation and engagement within a user-expert model.

A new public sculpture embodying and celebrating notions of youth's awkward presence and undetermined future has been added to the canon of public sculpture within Merseyside.

The reflective and transparent methodology employed in the studio, community engagement, exhibitions and specific site aligns this form of art practice to an artistic position concerned with the desire to reclaim public space for the celebration of uncertainty, awkwardness and bravado.

Director of Studies: Professor Jim Aulich

Supervisor: Professor Stephen Dixon

### **Acknowledgements**

I would like to express my gratitude to the following for their support during my research: Alan Dunn, all the young participants and staff from The Hub, St Mary's Catholic College, Weatherhead High School and The Oldershaw Academy, Alternator Studio, Arts Council England, Bluecoat Gallery, British School at Athens, Bryan Biggs, Castle Foundry, Central Park Partnership and Everyone's Café, Chris Butler, Chris Davies, Colin Simpson, Dave McNamara, David Hastie, DP Squared Ltd Structural Engineers, European Ceramic Work Centre, Friends of Central Park, Grundy Art Gallery, Heidi and Zak, Helen Wewiora, Holden Gallery, Jackie Smallwood, Laurie Peake, Lewis Biggs, Lisa Joy, Liverpool Biennial of Contemporary Art, Locws International, Lucas Wilson, Manchester Institute for Research and Innovation in Art and Design (MIRIAD), Manchester Metropolitan University, Naomi Horlock, Paul Kelly, Professor Jim Aulich, Professor Stephen Dixon, Rita Griffiths, Roger Cliffe-Thompson, Royal Society of British Sculptors, Sara-Jayne Parsons, Tony Trehy, Steve Chan, The Henry Moore Institute, Williamson Art Gallery, Wirral Council and Youth Support Service.

## Contents

### Part 1

	Page
Representation of youth through sculpture (Plates 1-130)	1-154

### Part 2

		Page
	Abstract	3
	Supervisory team and acknowledgements	4
	Contents	5-9
	Introduction	11
	The portrayal of youth: setting the scene	13
	Definitions of key terms	16
	Chapter outlines	17
Chapter 1	The messiness of the studio	
1.1	Pictures on walls	23
1.2	Embodied memory	26
1.2.1	Giving form (yeast, dough and iron)	27
1.2.2	The precious object	28
1.2.3	Light and darkness (life and death)	29
1.3	Mutterings in the studio	30
1.3.1	Chart of studio spaces	31
1.3.2	Occasional studio visits	33
1.4	Technology of making – tools of the research	33
1.4.1	Hands as primary tools of making	34
1.4.2	The temple and the forecourt	35
1.4.3	Drawings in the forecourt	37
1.5	Sculptural processes relating to modelling and casting	40
1.5.1	Modelling in plasteline	40



1.5.2	Modelling in clay and firing: ceramic	41
1.5.3	Modelling in clay for casting in stone or aluminium	45
1.5.3.1	Scale	46
1.5.3.2	Starting anew	46
1.5.3.4	Up-scaling tools	47
1.5.3.5	Casting shocks	49
1.5.4	Polychromatic surfaces on cast forms	50
Chapter 2	Pinboards tracing a historical context	
2.1	Pinboard 1, Motif 1: Youth in a state of rehearsing and displaying fitness and readiness through rituals, games, sport and dance	58
2.2	Pinboard 2, Motif 2: Youth in a state of inwardness and self-absorption	67
2.2.1	Gaze pinned down	70
2.2.2.	Eyes focused on an object and the interaction with that object	73
2.3	Pinboard 3, Motif 3: Youth in a state of physical vulnerability	75
2.3.1	Death and sleep	76
2.3.2	Violence	80
2.3.3	Physical Exploitation	81
Chapter 3	Interpretation of Gallery works	
3.1	Youth in a state of rehearsing and displaying fitness (readiness)	89
3.1.1	Taking care	90
3.1.2	Taking risks	95
3.2	Youth in a state of inwardness and self-absorption	97
3.2.1	Playful invisibility	97
3.2.2	Ostentatious withdrawal	99
3.2.3	Uncertainty	102
3.3	Youth in a state of physical vulnerability and fragile confusion	104
3.3.1	Death	104

3.3.2	Sleep	106
3.3.3	The passive and defenceless body: victimisation	108
3.3.4	Violence	111
Chapter 4	Celebrating waiting: context, development and interpretation of <i>Just wait for me</i> (2012-13)	
4.1.	Site-specificity and public art	115
4.1.1	Sculptural representations of youth on Merseyside	123
4.1.1.1	Youth as carriers of the future Empire	124
4.1.1.2	Youth as carriers of innocence	126
4.1.2	Features and undercurrents of the specific site in Central Park	128
4.2	Participation in contemporary art practices	131
4.2.1	Working with the Friends of Central Park, Wirral Council representatives and the Steering Group	138
4.2.2	Workshops with young people	140
4.2.2.1	The Hub	140
4.2.2.2	Schools	143
4.2.2.3	Grundy Art Gallery	145
4.2.3	Exhibitions of works from the workshops	145
4.3	<i>Just wait for me</i> (2012-13), interpretation	146
4.3.1	The approach	147
4.3.2	The piggybackers	148
4.3.3	The seated girl	148
4.4	Celebrating waiting	149
	Conclusion	
	The use of the double (one, two)	156
	One: the I in the world	156
	Two: the I and the representation of the I	157
	The significance of the double in the representation of youth	159
	Difference as a force for good	161

The user experience as a shared experience	162
Expert amongst experts	164
<i>Just wait for me</i> (2012-13), a statue of youth as carrier of 'awkward presence and undetermined future' sited in Central Park, Wallasey.	167
 Bibliography	 172-178
 Part 3	
 Funding and evaluation	
Arts Council application, October 2011	2-22
Arts Council interim report, July 2012	23-32
Arts Council final report, January 2013	33-40
Project Evaluation Report, Naomi Horlock, Jan 2013	41-73
 Structural Engineers Drawings	
DP Squared Ltd, August 2012	74-85
 Workshops	
List of workshops	86
Workshop handouts	87-89
 Minutes of meetings	
Minutes from Stakeholder meeting 09.05.2012	90-92
Minutes from Stakeholder meeting 19.06.2012	93-95
Minutes from Stakeholder meeting 12.07.2012	96-98
 Press articles	
Wallasey Riverside Labour, online, 19.11.2012	99
Wirral News, 31.10.2010	100
Wirral News, 1.11.2012	101
 Signage	

Sculpture plaque, October 2012	102
Sculpture interpretation panel, Dec 2012	103
Promotional material	
Birkenhead Park exhibition poster, Mar 2012	104
Leaflet for distribution in free newspaper, Sept 2012	105-6
Press release, Oct 2012	107-9
eflier invite, Nov 2012	100
Maps	
Merseyside	111
Studios and public sculpture of youth	112
<i>Just wait for me</i> (2012-13)	113





“The young are in character prone to desire and ready to carry any desire they may have formed into action. Of bodily desires it is the sexual to which they are the most disposed to give away, and in regards to sexual desire they exercise no self-restraint. They are changeful too and fickle in their desires, which are as transitory as they are vehement, for their wishes are keen without being permanent. They are passionate, irascible, and apt to be carried away by impulses. They are slaves, too, of their passion as their ambition prevents their ever brooking a slight and renders them indignant at the mere idea of enduring an injury. They are charitable rather than the reverse; they are sanguine too, for the young are heated by nature as drunken men by wine, not to say that they have yet experienced frequent failures.”<sup>1</sup>

Aristotle

## **Introduction.**

This ‘by-practice’ research explores the representation of youth through the development of new sculpture. The overall aim is to portray young people as awkward, boisterous, vulnerable and different in their relationship to themselves, each other and the world.

The research is driven by an ongoing sculptural practice and is submitted as artworks that are documented extensively within studio, exhibition and public settings. The research reveals recurring motifs within the sculptural representation of youth, such as their relationship with site and ‘community use’ from Antiquity to present day, and a large number of archive photographs of artworks are referenced throughout the thesis. In addition, historic evidential records such as minutes of stakeholder meetings, site maps, Arts Council funding application and handouts provide detailed evidence in support of the hybrid method for creating a socially-engaged site-specific permanent public sculpture for Merseyside.

In relation to the physical layout of the thesis, I weighed up two options for

organising this large amount of visual material, namely the substantial amount of referenced artworks, high quality documentation of my sculptural practice and the historic evidential records. One option consisted of collating all this visual material at the end of the written text; the other frontloaded the documentation of my sculpture, whilst inserting the referenced artworks into the text as and when they were discussed and adding the historical records at the end.

Based on this latter model, I have organised the thesis into three main parts. Part 1 consists of high quality large-scale photographs of my sculptural practice. Part 2 is the written text, interspersed with referenced artworks and thumbnails of my own work. Part 3 contains the historical evidence relating to the specific site, community and studio contexts. Submitting the research in these three parts may well be a little awkward, but after having considered the alternative option, I feel that the three-part approach provides the appropriate amount of space for high quality reproductions of both work-in-progress and finished sculptures whilst also allowing for referenced artworks to be viewed in detail throughout the text as and when they are discussed. To aid the reader throughout, the running order of the images in Part 1 corresponds to the chronological order in which the work is discussed in Part 2, which features smaller thumbnails.

Throughout the research I argue that the studio is the central locus of silent dialogues between *a priori* knowledge, the process of making new work and the incorporation and appropriation of the sculpture of the past. To make the significance of this non-linear dynamic transparent, I include work-in-progress photos in Part 1. Central to understanding the nature of the inter-connectedness between making in the here and now of the studio and the sculpture of the past is the methodology first introduced by Aby Warburg in his *Mnemosyne Atlas* (1924-29). Using pinboards that hold a variety of images from a range of sources and periods facilitates a different way of looking and thinking. The smaller photographs of my restaged pinboards and close-up photographs of referenced artworks throughout the thesis are included in Part 2. As mentioned, these referenced artworks, in both close-up and full, are located on the pages on which they are discussed, in support of the unfolding argument.

The running text of the thesis, albeit organised in chapters and subchapters, switches between past and present tense. This is perhaps in the English language an unorthodox use of tense, yet is an appropriation of my native German language. The switching between present and past is especially prominent in Chapter 1 and allows me to use the written word in its mimetic capacity, mirroring the open and fragmented thought processes that unfold in the making and the thinking. The restaged pinboards are chosen as visual vehicles that facilitate the extrapolation of youth-specific motifs in the cross-fertilisation between studio work and historical sculpture. A separate set of methods, including practical workshops and site analysis, is deployed in the development of the site-specific sculpture for Central Park. The statuettes produced during these workshops are made by 'experts' (see Conclusion) and are central to the development of the public sculpture and photographic documentation of them is included in Part 1. The research dedicates the separate and extended Chapter 4 to *Just wait for me* (2012-13) in the context of site-specific and socially-engaged public art, supported by the ancillary material including workshop hand outs, reports and press clippings as historical evidence in Part 3. Having provided the outline of the research strategy and its presentation across the three Parts, I will now set the scene for the research that commences and eventually returns to the specific context of Wallasey. This thematic and geographical setting of the scene is followed by essential definitions of key terms before concluding with an outline of the content of all the remaining chapters of the thesis.

### **The portrayal of youth: setting the scene.**

Imagine a society without the passion of youth, impulse or hope for the future. This would be a society that disregards its youth by creating conditions that are purely driven by the relentless expansion of a global market that "punishes all youth by treating them largely as commodities."<sup>2</sup> In his critique of the commodification of youth and the 'sell out' of potential futures, scholar and cultural critic Henry A. Giroux demonstrates the manners in which suppressive mechanisms such as night curfews for young people, privatisation of public spaces, education and the systematic dismantling of the democratic welfare state, in which everything has a monetary value, has already created a condition, where "any talk about the future has had less to do with young people than with short-term investment and quick turnovers."<sup>3</sup> His analysis into the marginalisation and subsequent commodification of young



black people within the American justice system makes grim reading, describing a highly commodified society selling out its potential future in two parallel ways. It forces young people into the combined shackles of student debt set against a highly competitive labour market or it economically marginalises young people to such an extent that their economic survival depends on low level but punishable crime which in turn feeds the privatised prison sector.

Whilst Giroux's book specifically highlights the plight of black youth in the USA, there are parallels with the post-industrial British context in which the research sits. My study begins in Wallasey, a densely populated urban district on the Wirral Peninsula, managed by Wirral Council within the Merseyside region. Cut off by the River Mersey, the cultural renaissance of Liverpool is largely inaccessible to young people on the Wirral. Living in the CH44 postcode (Liscard, Wallasey, Birkenhead), I see at first hand the area's high level of social deprivation (see 4.1.2), whilst eight miles away, families thrive in CH63 (Bebington, Spital), one of the most desirable areas in the UK.<sup>4</sup> As an artist and mother of children becoming teenagers I become aware of the contradictions of 'lack of opportunities' and 'too many opportunities' existing side by side. On one hand, adults and young people were giving up hope in relation to real and perceived lack of opportunities in education, employment or leisure, leading to second and third generation unemployment. On another, adults and young people thrive on the opportunities they have secured financially, driving profitable businesses in expensive gym clubs, afterschool activities and visits to Liverpool's gentrified shopping centre, Liverpool 1.

The research commences in the specific context of Wallasey and returns there for the installation of my permanent public sculpture *Just wait for me* (2012-13). The late sociologist Zygmunt Bauman claims "Giroux has been one of the most consistent and outspoken defenders and promoters of the life-prospects and human dignity of which young generations were robbed or which they were prevented to recognize as their birth rights."<sup>5</sup> Giroux's publications in the field of youth and education studies serve also as critical warnings to the future of democracy in neoliberal societies such as the USA. Like Aristotle, Giroux firmly believes that democracy and its future are linked to the wellbeing of youth. He asserts that the democratic future of a society was and is dependent on the recognition of the social contract between the generations as a moral and political contract. The manner

in which “a society imagined democracy and its future was contingent on how it viewed its responsibility toward future generations.”<sup>6</sup> These responsibilities should be understood as collective responsibilities of the guardianship for the young. This guardianship is demonstrated through education, training and the provision of resources. It is also through respect, tolerance of the other, dignity and freedom to develop in public and private spheres.

Many recent authors in youth studies<sup>7</sup> conclude that this freedom for young people to express themselves in urban areas and public spaces has increasingly been restricted by parents, police and other factors.<sup>8</sup> These other factors include young people self-restricting as a result of experiencing threats from other groups of youths stemming from territorial rivalry or alcohol-fuelled disputes.<sup>9</sup> The freedom of self-expression has been hijacked by today’s dominant media that underpins the neoliberal politics of the USA and the UK. Academics Susan Linn and Juliet Schor also observe a tendency to portray young people as either lazy, stupid, self-indulgent and unworthy of compassion or as consumers of designer goods and prime targets for global corporation marketing departments.<sup>10</sup> No longer “viewed as a privileged sign and embodiment of the future,”<sup>11</sup> youth is now “increasingly demonized by the popular media and derided by politicians looking for quick-fix solutions to crime and other social ills.”<sup>12</sup> An example in Wallasey would be the media and local politicians initially holding young people responsible for the vandalism of Liscard Hall (see 4.1.2). When young people are portrayed in the media as the cause of disorder and crime and roles available to them are largely those of the consumer, “the private sphere has become the only space in which to imagine any sense of hope, pleasure or possibility.”<sup>13</sup> As geographer Gill Valentine notes, when public spaces including local parks, town squares and streets become increasingly privatised and policed, their significance as spaces of cultural activity, community participation, public stories and political struggle diminishes.<sup>14</sup>

The research into the sculptural representation of youth takes place within this context of cultural privatisation. My aim is to create a different image of youth in the specific contexts of public statuary on Merseyside and galleries. The research regards youths as future holders, guarantors and symbols of tomorrow. It does this by representing youth as a state of being that demands compassion, trust and respect. It realises this through a locally situated and artist-led approach that brings

together recurring motifs from the representation of youth with detailed insights into my perspective on and sculptural practice in relation to specific local settings. As such, the research registers the symbolic imagery of youth as “a guarantee that the present has the power, even in unpredictable ways, to shape the future.”<sup>15</sup>

### **Definitions of key terms.**

Prior to outlining the content and emphasis of Chapters 1-5, I will provide a brief framing of the key terms used. By the term *youth* I mean the relative age of young people who hold a position of semi-dependence, at some time reminiscent of childhood (dependence) and prospective of adulthood (independence).<sup>16</sup> The term youth allows for the inclusion of historical examples of representations from Greek Antiquity that left behind significant numbers of statues and statuettes depicting youth.<sup>17</sup> Although it has been argued that the term *adolescence*, deriving from Latin *adolescere* (to grow to maturity),<sup>18</sup> has been used since the end of the nineteenth century, the introductory quote by Aristotle demonstrates that the characteristics of youth, such as bashful demeanour, violent impulses and emotional exertions are far from new. Youth is widely regarded as “a period in life in which choices begin to be made and identities are formed.”<sup>19</sup> Thus within the context of this research, I also use the word adolescence to describe the period between the twelfth and the twentieth year, a time of transition into adulthood.<sup>20</sup>

The term *sculpture* in the context of this research is used alongside the terms *statue* and *statuette* to refer to three-dimensional objects made in materials such as stone, bronze, wax, ceramic, plaster and polyester. The term statue, deriving from Latin *statua* (to stand) refers to figurative works depicting humans or animals that are free standing to be viewed in the round. The materiality, the surface and form of sculpture ‘speaks’ without words; mute, but nevertheless with an intimation that is immediate, infinite (boundless) and magical.

“The language itself is not fully expressed in the things themselves. This theorem has a double meaning for the transmitted and sensuous meaning: the languages of things are imperfect, and they are mute. The pure linguistic principle of form - the sound - has failed. They can communicate with each other only through a more or less material community. This community is

immediate and infinite, like that of any linguistic communication; it is magical (for there is also magic of matter).”<sup>21</sup>

Walter Benjamin

Throughout this research the term *figurative sculpture* is avoided, preferring the afore-mentioned terms statue or simply sculpture. The term *representation* is used to describe the outwardly recognisable elements of the sculpture. More fundamentally, representation refers to the *imitation* that is omitted from the sculpture, and what Benjamin terms *Das geistige Wesen* (the spiritual essence).<sup>22</sup> Thus by representation I refer to the material element of the depiction of adolescent boys and girls and the spiritual essence or soul of these three-dimensional images. Philosopher José Ortega Y Gasset describes this form of representation as a construction that is not a copy of nature yet possesses substance of its own.<sup>23</sup> Sculpture and the reflective making and thinking through sculpture are the core elements of the thesis. In order to make transparent the interdependence between making and its context, the emphasis of each chapter shifts from the close up perspective of the studio to the wider perspective of the historical context before returning to closer scrutiny of the artworks submitted. Finally, I use both the terms Liverpool (city) and Merseyside (region) to describe my working context, with the former being used more in reference to specific projects (eg the Liverpool Biennial).

### **Chapter outlines.**

Chapter 1 is concerned with the studio environment. The physical nature of the studio, the pictures and drawings pinned to the walls, the materials and processes employed in the making and the *a priori* experience of the artist/researcher influence the development of the sculpture through silent dialogues. The focus of Chapter 1 is on the articulation of these dialogues, through notions of *ur*-experiences, contrived and non-contrived modes of making as stipulated by the art historian Edgar Wind and philosopher Benedetto Croce. Chapter 1 concludes with a closer investigation into the modeling processes, malleable materials, surface colours and their effect on form-finding.

Chapter 2 examines the historical context of the sculptural representation of



youth. Acknowledging that all artworks are interdependent and borrow from “signs, symbols, materials, and syntax that have already been developed”<sup>24</sup>,

Chapter 2 postulates that there are three primary motifs specific to the sculptural representation of youth that permeate from Antiquity to the present. By applying art historian Aby Warburg’s methods of *Bildtafeln* (pinboards), first introduced in his *Mnemosyne Atlas* (1924-29, Fig. 29), it is possible to recognise the recurrence of motifs across sculpture representing youth. Appropriating this method in my own studio and research aided the understanding of the dialogue between the making and its historical influences. My restaging of pinboards is illustrated through details and fragments and captures examples of subconscious pictorial influences. It is not one single *über-Atlas*, partly due to the shifting studio contexts discussed in Chapter 1. Instead it is a representation of a process. There are three distinct and overlapping motifs that permeate through all the quoted historical artwork: namely youth as states of rehearsal, inwardness, withdrawal and vulnerability. Chapter 2 considers these motifs in relation to sculpture by other artists dating back to Antiquity.

Chapter 3 focuses on my sculpture exhibited in galleries and develops the previous chapter’s consideration of motifs, referring to and including thumbnails from the Part 1 Plates. The Chapter addresses each motif and discusses my own work in relation to them. In doing so, each is further broken down into a series of ‘almost opposites’, each category containing its own contradiction. For example, the rehearsing of physical fitness shifts into taking risks and vulnerability mutates into victimisation and fragile confusion. Chapter 4 examines the development and realisation of my public sculpture *Just wait for me* (2012-13) in Central Park in Wallasey (see maps in Part 3, p.111-113). It outlines the process behind self-initiating a major work of public art, through personal local experience, site analysis, workshops with young people in formal and informal settings, securing funding and permissions from Arts Council England (ACE) and Wirral Council respectively and community liaison. It appraises notions of site-specific and participation in a public art context, considering the writings of Claire Bishop, David Harding and Grant Kester to question current thinking around who produces – and with whom – locally-based public art. Chapter 4 is supported by the appendix in Part 3, consisting of meeting minutes, workshop itinerary, funding application/reports and project evaluation.

The Conclusion draws out the unique contributions the research makes to the sculptural representation of youth. It begins with the uses of the single, double and triple figure(s) and its impact on extending the three motifs. In relation to Benjamin's idea of a sculpture's 'spiritual essence', I consider how the tensions between the figure as an *I* and its surroundings in *the world* are expressed sculpturally. Following on from Warburg's suggestion that art "expresses psychological tensions between irrational and rational impulses"<sup>25</sup>, I apply Otto Rank's psychoanalytical literary study *The Double* (Rank, 1971) to the interpretation of the nature of representation expressed in the use of the double figure(s). Specifically, through my research the double figure is understood as a representation of the three-dimensional reflection of the figure as self with its own image in time and space. As such, the double figure extends the three motifs of sculptural representation of youth by amplifying the states of uncertainty, awkwardness and being in limbo.

The next section of the Conclusion concentrates on the empowering use of distance, difference and the user experience as the conceptual glue that holds together *Just wait for me* (2012-13). Within the context of public statuary of youth on Merseyside and the 'curatorial matchmaking approach' to socially-engaged practice, the methods underpinning the evolution of *Just wait for me* (2012-13), and the actual sculpture, itself fill two significant gaps in knowledge. The first gap is in relation to methods of socially-engaged, 'local' and site-specific public art. By developing a method that instantiates a combined studio and community-based practice within a context that is local to the artist, *all* participation and engagement is defined as a *user-expert* experience. This is an alternative model to that of major institutions such as Liverpool Biennial as discussed in Chapter 4. The second gap is marked by the distinct lack of new site-specific public sculpture celebrating notions of youth's awkward presence and undetermined future. My conclusion highlights that in the context of public statuary of youth on Merseyside, *Just wait for me* (2012-13) adds a new and contemporary representation of youth that embodies states of ambiguity: vulnerability and strength, awkwardness and elegance and uncertainty and bravado.<sup>26</sup> These states are rehearsals of relationships with the world, the self and each other and as such they occupy and claim space as 'holders of the future', requiring attention and compassion in the public domain.

## Endnotes

1 Aristotle *Rhetoric*, 4th century BC, quoted in Vitale, G., *Anthropology of Childhood and Youth: International and Historical Perspectives*, 2014, Lexington Books, Maryland, pXIX.

2 Giroux, H., *Youth in a suspect society: Democracy or Disposability?* 2009/10, Palgrave Macmillan, New York, pXII.

3 *ibid* pX.

4 Wirral View, *Bebington - England's most desirable place to live (still!)*, online, available at: <https://tinyurl.com/k6ceasl>, [accessed 10.4.2017].

5 Bauman, Z., *THE TWILIGHT OF THE SOCIAL: RESURGENT POLITICS IN AN AGE OF DISPOSABILITY*, 2012, online, available at: <https://tinyurl.com/k8tz2zg> [accessed: 9.4.2017].

6 Giroux, p12.

7 Examples include: Sukarieh, M. and Tannock, S., *Youth rising? the politics of youth in the global economy*, 2015, Routledge, New York/London. Helve, H. and Wallace, C., *Youth, citizenship and empowerment*, 2001, Ashgate, Aldershot. Heath, S. and Walker, C., eds. *Innovations in youth research*, 2012, Palgrave Macmillan, New York/London. Tienda, M. and Wilson, WJ., eds. *Youth in cities: a cross-national perspective*, 2002, Cambridge University Press, Cambridge. Horschelmann, K. and Colls, R., eds. *Contested bodies of childhood and youth*, 2010, Palgrave Macmillan, New York/London. Valentine, G., *Public space and the culture of childhood*, 2004, Ashgate, Aldershot. Skelton, T. and Valentine, G., eds. *Cool places: geographies of youth cultures*, 1998, Routledge, New York/London.

8 Schildt, A., ed., *European cities, youth and the public sphere in the twentieth century*, 2005, Ashgate, Aldershot, p92.

9 *ibid* p103.

10 Giroux, p14.

11 Linn, S., *Consuming Kids*, 2004, Anchor Books, New York, p58.

12 Giroux, p19.

13 Linn p54.

14 Valentine, G., *Public space and the culture of childhood*, 2004, Ashgate, Aldershot.

15 Grossberg, L., *Caught in the crossfire: kids, politics, and America's Future*, 2005, Paradigm Publishers, London, quoted in Giroux (2009/10), p28.

16 Kleijwegt, M., *Ancient Youth - The ambiguity of Youth and the absence of Adolescence in Greco-Roman Society*, 1991, J.C. Gieben, Amsterdam, pXIII.

17 *ibid* p30, Kleijwegt argues that adolescence as we now know it did not exist in pre-industrial time. Youth did however and was regarded in ancient Greek and Roman times as the "period leading up to

social acceptance into the adult world” which was longer and different in character.

18 Shute, R and Sleet, P., *Child Development: Theories and Critical Perspective*, 2015, Routledge, Oxford, p58. Acknowledging the impact of G. Stanley Hall’s publication *Adolescence: Its Psychology and its Relations to Physiology, Anthropology, Sociology, Sex, Crime, Religion and Education*, 1904, Shute and Sleet argue that the concept of adolescence existed prior to Hall’s child development research.

19 Schildt, A. and Detlef, S., eds. *European cities, youth and the public sphere in the twentieth century*, 2005, Ashgate, Aldershot, p135. See also Schindler, N., *Guardians of Disorder: Rituals of Youthful Culture at the dawn of the modern age* (pp240-282) in Levi, G. and Schmitt, J-C., eds. *History of Young People*, 1997, Belknap Press, Harvard University Press, Cambridge, Mass. and London, p246. Youth is described as a formative period void of material worries and usually ending with the setting up of one’s own home and leaving the parental home.

20 Erikson, E., *Identity, youth and crisis*, 1968, W. W. Norton Company, New York, p4.

21 Bullock, M. and Jennings, M., eds. *Walter Benjamin: Selected Writings, Part 1: 1913-1926*, 2004, Belknap Press, Cambridge Mass. and London, p147. The original German reads: “Die Sprachen der Dinge sind unvollkommen, und sie sind stumm. Den Dingen ist das reine sprachliche Formprinzip - der Laut - versagt. Sie können sich nur durch eine mehr oder minder stoffliche Gemeinschaft einander mitteilen. Diese Gemeinschaft ist unmittelbar und unendlich wie jede sprachliche Mitteilung; sie ist magisch (denn es gibt auch Magic in der Materie).” From the essay *Über die Sprache überhaupt und über die Sprache des Menschen* included in Tiedemann, R. and Schweppenhäuser, H., eds. *Gesammelte Schriften II*, 1977, Suhrkamp Verlag, Frankfurt/Main, p140-157.

22 *ibid* p141.

23 Gasset, J., *The Dehumanization of Art and Notes on the Novel*, 1925, reprinted 1951, NY Peter Smith, with permission of Princeton University, p23.

24 Levine, C., *Provoking Democracy: Why We Need the Arts*, 2007, Wiley-Blackwell, UK, p149.

25 Hatt, M, and Klonk, C., *Art history, Critical introduction to its methods*, 2006, Manchester University Press, p99.

26 Kleijwegt p43.



## Chapter 1 - The messiness of the studio.

This chapter focuses on the slow drip of thought that underpins the messy activity of a sculptor's studio work. It articulates the feel of the studio, the silent dialogues and the clutter and comings and goings of studio visitors, with the aim of taking "the making along with the talk about the making."<sup>1</sup> The studio work evolves out of apparently accidental encounters while working with a variety of source materials. Together these provide the context for the development of the original artworks submitted. I use the term encounter to describe an unexpected meeting or experience, a rubbing against something new and perhaps difficult, a meeting that may not have been actively sought but that appears or springs upon the artist/researcher and demands some type of reaction. This chapter considers the nature and content of these encounters in terms of the visual surroundings (1.1 and 1.2), the physical and peer surrounds (1.3) and the tools required (1.4). The chapter concludes with reflective interferences caused by the various sculptural processes used throughout the research (1.5). Contrary to the simultaneity of space and time in the studio, these chapter sections lay out on a flat surface what are fundamentally 'in the round' encounters in time and space with a variety of embodied *ur*-experiences, silent dialogues with the images on the wall, the work unfolding and the verbal comments made by studio visitors. It is important here to explain my use of the term *ur*-experience that has no direct English translation. As a prefix, *ur*- refers to the original, the proto or the primitive, namely the foundations before conscious experience. An *ur*-experience hence is one that occurs before intellect dissects and understands its significance.

## 1.1 Pictures on walls.



Fig. 1 Postcards on wall of Alternator Studio (restaged 2017). Image by Brigitte Jurack.

Pictures on walls feature in this chapter and in the historical context in Chapter 2. The studio wall visually resembles Aby Warburg's *Mnemosyne Atlas* (1924-29, Fig. 29) discussed in that chapter and stimulates the active thought process in the studio. Whilst Chapter 2 critically reflects on the importance of Warburg's work to my research, the following images of paintings, sculpture and other objects are of equal significance and are shown to illustrate the *a priori* and background to my studio practice (Fig. 1):

Colour photograph of bronze arm and hand, from The Antikythera Shipwreck, dating from the Hellenistic period, National Archaeological Museum, Athens, photograph by Brigitte Jurack.

Colour postcard of the statue of Stefano Maderno *Santa Cecilia* (1599), Basilica di S. Cecilia in Trastevere, Rome.

Colour postcard of the Paolo Uccello painting *Young Lady of Fashion* (1397-1475), Isabella Stewart Gardner Museum, Boston.

Colour photograph of a folded frottee towel, British School Athens.

Colour photograph of injured Anjouan man, photographer: Jose Cendon/AFP/Getty.

Colour postcard of Giovanni Lorenzo Bernini *Estasi Di Santa Teresa* (1647-52),

Cornaro Chapel, Santa Maria della Vittoria, Rome.

Colour postcard of Eduard Vuillard *Girl wearing an Orange Shawl* (1894-95), National Gallery of Art, Washington DC.

Colour postcard of *The Dormition of St Ephrem the Syrian (details)*, Holy Meteora.

Colour postcard of the Two-Headed Calf, born in the 19<sup>th</sup> century in Upper Teesdale, The Bowes Museum, County Durham.

Black & white photograph of Torso of Apollo. Roman copy after a statue of the school of Polykleitos, ca. 430–420 BC, photograph by Brigitte Jurack.

Each of these images has an impact and a silent lingering presence. Everything is constantly in the background, with each image hovering for attention like post-it-notes. They are reminders of the enormity of the world. At this stage I wish to introduce the work of Dutch sculptor Mark Manders, whose ceramic work and writings are highly relevant to my own research. Born in 1968, Manders' practice evolved through a series of figurative works, often displayed as split figures appearing at once vulnerable and strong. The figures are often presented in conjunction with functional furniture. For the figures' postures, hairstyles and facial features, Manders' appropriates sculpture from the past, especially the archaic and early classical period in Greek and Etruscan art. He articulates this ubiquitous presence of the past and its potency for work in his writing and as a practicing artist he feels that he has the whole world available to him and he can thus use the four walls of the studio as a conjuring space.<sup>2</sup> Having developed the concept for inhabiting a self-portrait as a fictional building since 1986, Manders states that "this building can expand or shrink



Fig. 2 *Uta von Naumburg*, Naumburg Cathedral, Germany (1250). Image from <https://tinyurl.com/hwkp6f4>.

at any moment. In this building all words created by mankind are on hand. The building arises, like words, out of interaction with life and things. The thoughts that surround him in his building are, materialized or not, always important and never gratuitous."<sup>3</sup>

From within the visual ambience of my studio, I focus on two images, firstly that of the *Uta von Naumburg* (mid-13C, Fig. 2), a statue in the Naumburger Dom in Germany.



Fig. 3 *Two-headed calf*, Bowes Museum (date unknown). Image from <https://tinyurl.com/zknjff9>

The second is a picture postcard of a two-headed stuffed calf on display in the Bowes Museum, Darlington. Not having seen the former, a masterpiece of the German Gothic, in the original, the black and white photocopy of her torso and head is integral to my understanding of what sculpture is able to perform. The statue commemorates one of the donors of the Naumburger Dom. Carved around 1250, it has been recognised as an idealised portrait of Uta von Ballenstedt (1000-1046) that, according to art historian Erwin Panofsky, signifies the dawn of a more expressive form of sculpture in Northern Europe. Whilst earlier medieval

sculpture in Northern Europe were void of a suggestion of a particular character, the unknown sculptor creates a statue that emits a sense of individual strength, drive and purpose, thus creating a portrait statue that connects the soul irreversibly to the individual body whilst also remaining simultaneously free from it.<sup>4</sup> Panofsky cites that at the time the Naumburger Dom founder figures were carved, Thomas von Aquino's (1225-1274) writing paved the way for a renewed understanding of the soul as intrinsically and non-dividable connected to the body; the soul is identified as the characteristic that differentiates being alive from not being alive. In short, *Uta von Naumburg* (mid-13C, Fig. 2) gains her significance due to the fact that she articulates a re-emerging individuality in German Cathedral statuary.

Panofsky describes her presence as a form of revelation, as if emotion emanates and glows out of the very fabric of the statue. Framed by the high collar of her coat, her face and gaze into the distance seem enlivened by an autonomous will and emotion. Yet, positioned in the cathedral as one of twelve statues of founders, this emanating and emerging individuality remains dialectically bound by the body - her own body - but also the body of the other donors and the church at large. As an undisputed masterpiece of early Gothic sculpture of Germany, she was also misused as a national icon during the National Socialist regime, representing the image of the ideal Germanic woman. On my wall, the black and white photocopy of her face, framed by the high coat collar, becomes the aspirational leitmotif for my studio-based research. The statue suggests glimpses of individual uniqueness embedded in the larger body of the afore-mentioned circle of founders and the site



of the cathedral. As such, she is the link between ancient Greek sculpture of the early classical period and the sculpture of Northern Europe. Just like the Greek *Kore* (Figs. 50,51) described in Chapter 2, she is part of a group of statues, occupying the walls of a sacred space above the congregation. She is there to be remembered and at one time celebrated. The postcard of the two-headed calf (date unknown, Fig. 3) on display at the Bowes Museum hangs on the same studio wall as a reminder of what Manders describes as “reality and its rich infinite vocabulary.”<sup>5</sup> A freak of nature from the nineteenth century in Upper Teesdale, the calf is displayed alongside tapestries, paintings and porcelains. The two heads are attached to each other and look in slightly different directions. They fix permanently what we normally experience as movement, which is looking from one side to the other. One-headed beings can at any one time turn and look only one way to the exclusion of the other. This two-headed calf appears to look both ways at the same time. The image of the double-head emanating from the reality of the Bowes calf provides a hook and a kind of germinating seedling for the double figures discussed in Chapters 3 and 4. This image begins my research into sculpture that can hold an image of what is often experienced as internal conflict such as vulnerability and control, left and right, play and violence or un/certainty, themes I shall return to specifically in the Conclusion.

## 1.2 Embodied memory.

My research and the sculpture in the studio are also influenced by what can be described as a re-surfacing of embodied memory of physical encounters with sculpture. These encounters, like year-rings on trees, grow outwards from a set of *ur*-experiences with three-dimensional materiality. The boundaries between the personal and autobiographical and the development of an aesthetically educated western European artist are slippery, yet these *ur*-experiences and subsequent physical encounters make up the author’s engine that sends the pulses for *Bildhauerei*. The German word for sculpture used here is nearer to the impulse for image making as the term *Bild* (in English, picture or image) is combined with the word for chiseling; literally the chiseling of an image out of a material. The seed for the impulse to actually make something, and being taken over by *that which is in the process of being made*, has been sown by *ur*-experiences and built upon through embodied experience.

This less obvious strata of experience has to be declared for the purpose of transparency and coherence. These *ur*-experiences form my belief in the animate within the inanimate. They are shaped by the cultural contexts of my upbringing and education which in turn influences the technology of making, the fetishisation of objects, the investment into dead material and the belief in the transformative power of the three-dimensional object. The cultural and historical uniqueness of these encounters mentioned below are embedded in the understanding of what art historian and theorist Hans Belting describes as an anthropological approach to image-making that proposes “a close and fundamental interrelation (and even interaction) of image, body and medium as components in every attempt at picture-making”<sup>6</sup> that commences with funereal images, “as it is in the *missing body* of the dead in whose place images are installed.”<sup>7</sup> For Belting, the “*lost body* is exchanged for the *virtual body* of the image ... that very contradiction which will forever characterise images: images make a physical (a body’s) *absence* visible by transforming it into iconic presence.”<sup>8</sup> For Belting, dreams, pictures, statues or artifacts are the tangible components that carry or hold an image. Anthropologist Michael Taussig situates the impulse for image-making and more explicitly representational image-making in the anthropological need to gain control, as an act of empowerment and “to see anew the spell of the natural where the reproduction of life merges with the recapture of the soul.”<sup>9</sup> Belting quotes from art historian Carl Einstein’s methodical aphorisms, “the image is a consolidation and a defense against death. Our existence is unalterably an experience of space. It is in this sense that art serves the dead: by restoring a space for their representation.”<sup>10</sup> The personal desire and ability to create images that may be held or emitted from tangible objects, but may also appear in dreams, mirages, music or dance is embodied in an anthropological *ur*-experience to which specific historical settings add personal experiences.

### **1.2.1 Giving form (yeast, dough and iron).**

Our family apartment was above the bakery in which my mother worked. Every week she would make a yeast-based dough on the kitchen table for cakes and bread. As a child I was fascinated by the transformation of a simple mix of yeast, flour and water into a solid form. The first encounter with the magic of transformation of a malleable material took place in that kitchen in which a woman shaped and

controlled form. My maternal grandfather had built a home forge in the back room of a hastily re-built post-War townhouse. During my school holidays I watched this former Nazi soldier forge metal into candlesticks and garden gates. I was again fascinated by the glowing metal being beaten into intricate shapes by a man who held unacceptable ideological views to me. He was the first person I had seen sketching intricate designs of forged gates and street furniture and later scaling up these drawings as patterns for the production process. To this day, we still use one of my grandfather's candlesticks in our family home. Both these experiences are crucial in the understanding of my deep-rooted belief in the power of *form-giving* and a more subtle awareness of the aura of objects, via the maternal kneading hands and the patriarchal anvil and fire.

### **1.2.2 The precious object.**

Being the child of parents and grandparents who literally lost everything in WWII, our family's almost intact gold-rimmed china coffee set and complete chest of family silver and dining Meissen crockery acquired a symbolic value of survival. Neither sold during pre- or post-war inflation nor destroyed in air raids, my relationship to these objects is marked by shame, guilt and wonder. The only remaining items apart from one cardboard-bound photo album were treated by the surviving generation with the utmost care and respect. Beyond that, all material objects such as furniture, house and car, both East and West of the Iron Curtain, were slowly assembled and cared for: not replaced, but considered to last. The acquisition of mundane objects and care for the gold-rimmed coffee set were invested with the symbolic values of survival and new beginnings. The aforementioned narrative and material uniqueness prohibited everyday use and thus heightens the sense of the aura of the china. Its usage was connected with special occasions such as birthdays or funerals and as such it warranted a regular 'coming to life' of a specific past. As symbolic carrier of this past its regulated usage prevented the past from receding completely and amidst the newly purchased everyday crockery; this usage also warranted that the past never overshadowed the present.

### 1.2.3 Light and darkness (life and death).



Fig. 4 Johannes Knubel *Pallas Athena* (1926). Image from <https://tinyurl.com/hs5xmye>.



Fig. 5 Mummy at the Bleikellercrypt (c1618), St. Petri Cathedral of Bremen, Germany, Image from <https://tinyurl.com/j2avwh8>.

My initial encounter with form was the transformation of malleable material into beautifully-shaped edible cakes and usable garden gates and candlesticks. This was followed by the introduction to functional forms, such as the china set as carriers of symbolic value. Whilst these *ur*-experiences took place in the family home, these next encounters were in the public and shared arena of churches and the built environment. These provided the initial introduction to the power of representational figurative art and its relationship with life and death. Glowing in the sunlight, the neo-classical gilded bronze *Pallas Athena* (1926, Fig. 4) by Johannes Knubel was the first statue I saw regularly as a child whilst traversing the River Rhein by tram. Standing high at the ramp that connected the Rhein Bridge with the 1920s brick-built German expressionistic Ehrenhof Exhibition Complex, the statue showed a simple frontal pose composition of ankle-length chiton with one arm hanging down at the side and the other holding a very long vertical spear. The statue seemed to belong to another world, a world of order and with exquisite proportions and a spectacular golden glow, she hovered above the noise and rattle of the tram. This encounter laid the foundations for an understanding that materials such as bronze and gold could emit a sense of steadfastness and reassurance and a very attractive bright glow. In contrast, experiencing a living material that has solidified yet appears dead took place in the dimly lit East Krypt (Bleikeller) of the St. Petri Dom of Bremen. As a child there, I saw *eight mummies* (c.1618, Fig. 5) lying in open coffins. It was said that the building's roofing lead stored in the East Crypt contributed to the mummification process. The dark subterranean surroundings of the display certainly added to the elementary understanding that without light, the life resemblance of the mummies had diminished. Unlike the gilded neo-classical *Pallas Athena* (1926, Fig. 4), the grey cadavers did not emit a bright glow but a



petrified and arrested dark silence. Their lead-colored folded hands, wrinkled skin and fingernails looked dead. Such memory images, together with the pictures on my studio wall, informed the *a priori* of this research into the portrayal of youth through sculpture. They signaled that the experience of sculpture, its making and reception, is always bound by the embodied experience of the *I*. This includes encounters with form-giving, the use of objects, and the experience of the image (*das Bild*) as *the other* that is actually ahead of the material presence. It also includes the continuous exposure to a range of artworks and artifacts of which reproductions hang on the studio wall as reminders, quiet infiltrators and challengers. Warburg's assembly of images derives from "numerous sources across cultures and history juxtaposed in ways that brought out their gestural, animated qualities"<sup>11</sup> and thus allows for the recognition that "images were not first and foremost units of signification, but elements in an essentially ritualistic handling of the world. Traces or effects of the attempt to tame the inexplicable forces of nature and to reconstitute or reconfigure social relations."<sup>12</sup> This method of assembling images on pinboards to facilitate thinking and understanding has recently been used by art historian Martin Warnke in *Flüchtlinge ohne Schlepper*.<sup>13</sup> Revisiting the image index of political iconography at the Warburg Institute demonstrates how similar the iconography of migrating people across centuries, including ours, really is. This is an important denominator within my research, namely extracting motifs from across cultures and eras to better understand the manners in which we use sculpture to develop our knowledge around the transitional period of youth.

### **1.3 Mutterings in the studio.**

Throughout the lifetime of this research, different studios and locations are used to develop and fabricate artworks. The physical nature of these studios, including dimensions, layout, temperature and location greatly impact upon the development of my work, most notably in relation to scale, number of figures, materials and technologies employed. It is of use here to introduce this *Chart of studio spaces* as locations for my practice. It is through this studio journey, the encounters and visual environments that the importance of physical space and the ability to create sets of figures emerges.

### 1.3.1 Chart of studio spaces.

The chart indicates the correlation between the dimensions of studio, ground floor accessibility, dimensions of kilns and the size of the work produced. It also indicates each studio's suitability in terms of working on several pieces simultaneously. Furthermore, factors such as quality of light and access to appropriate viewing distances of approximately 5-10m are noted. The locations of the Merseyside studios are recorded in the map in Part 3, p.112.

Venue	Description	Works produced there
Newcastle School of Art Summer studio (June 2002)	Large, well-lit ground floor studio with roof lights and sufficient distance to view the work. Double door and gantry available for lifting and moving sculpture.	<i>Boy with jacket</i> (2002, Part 1 Plates 80-82) Larger than life-size figure, modelled on welded metal frame, as one continuous piece, molded in plaster, cast in Jesmonite AC100.
European Ceramic Work Centre, Herzogenbosch, Netherlands (March and April 2009)	Fully equipped specialist ceramic work centre, including technical support staff, front-loading large kilns and hydraulic lifting devices. Lighting was poor (strip lighting) which flattens the surface. The square studio layout makes viewing from distance impossible.	<i>Boy with parasol</i> (2009, Part 1 Plates 59-63) First life-size ceramic sculpture, modelled in one continuous form, fired in one piece and fully glazed.
Summer studio in a former Technical College and 1960s Primary School, Bootle, Merseyside (July and August 2009)	Located in an empty 1960s primary school, it had stripped walls and was extremely well lit with daylight. I worked in a large classroom, big enough to work on two figures ( <i>Waiting</i> ) at the same time. Studio also had ground floor double door access and enough space to view the work from distance. Summer temperatures allowed for fast paced work as the clay dried quickly.	<i>Boy with mouse</i> (2009, Part 1 Plates 54-58) <i>Waiting</i> (2009, Part 1 Plates 25-30) First life-size figures, modelled in sections due to size of available kiln and transportation needs, driven in leather-hard state from Bootle studio to Manchester Metropolitan University for firing. Both fired in sections due to size of kiln.

British School Athens, Greece January studio (January 2011)	Attic room with poor light and a very narrow access. Availability of excellent archive and library.	<i>Untitled</i> (2011, Part 1 Plates 2-16) Group of smaller statuettes produced.
Domestic house studio, Wallasey (2003 – 2010)	Evenly-lit space with north facing windows in 6x5m former reception room with limited space to view from distance.	<i>Monument for Damian</i> (2008, Part 1, Plates 66-72) <i>Girl with fire</i> (2011, Part 1 Plates 64,65) The latter transported to and fired in Manchester Metropolitan University in sections due to size of kiln.
Privately-hired studio by NPO Motors, Oxtou, Wirral (April 2011-March 2012)	An attic room with narrow access stairs that made it impossible to move anything heavy or large up and down to the studio. Absolutely no viewing distances.	<i>Untitled</i> (2011-12, Fig. 17-24) Group of smaller statuettes, drawings (Figs. 6-23) and 1:4 model of sculpture for Central Park.
Purchased studio, Alternator Studio, a former Bakery, Birkenhead, Wirral (March 2012- )	A large Victorian Bakery dating from 1900 with ground floor access through double doors and enough space to stand back to look at the work from distance. Enough space to work simultaneously on two figures. The studio is damp (summer and winter) which allows for slow drying of clay. This is beneficial when working on two pieces simultaneously.	<i>Just wait for me</i> (2012-13) <i>Sleeping Beauty</i> (2015, Part 1 Plates 83-90) <i>Dunno</i> (2016, Part 1 Plates 73-79) <i>If only</i> (2015, Part 1 Plates 91-96) <i>Boy with knife</i> (maquette 2017, Part 1 Plates 97,98) A series of larger than life-size sculpture. The sculpture for Central Park was modelled on a metal frame, molded by Castle Foundry and cast off-site in aluminum. The other Central Park figure, the seated girl, was molded and cast in Jesmonite AC730 in the studio. Remaining figures created in clay, modelled in sections and pairs and fired at Manchester Metropolitan University.
Castle Foundry assembly shed, Liverpool (2012)	Large industrial unit with strip light.	<i>Just wait for me</i> (2012-13) Coating and painting of <i>Just wait for me</i> (2012-13).

As can be seen, the temporary use of the former Technical College was crucial in introducing the possibility of working on two figures at the same time. Or rather, two versions of the same figure; the mirror or double. Purchasing the former Bakery in February 2012 maintained my ability to work on more than one clay figure at a time. The former Technical College also introduced me to vernacular tables

and chairs that would become the support for the sculpture, not only in the studio but in exhibitions too. The use of eight differing spaces within this research may not have been ideal but the physicality of each studio contributed to and progressed my studio practice.

### **1.3.2 Occasional studio visits.**

Having charted the studio as a space in which materials, things and thoughts are in the process of becoming, it is important to also recognise the four walls as a space for critical interruptions. These are undertaken throughout the research by various stakeholders, significantly other creative practitioners, those advising on the ACE application (Part 3, p.2-22) young people involved in workshops and the Steering Group members assembled for the permanent sculpture discussed in Chapter 4. Studio visits other than those by the Steering Group during my research are not recorded but immediately followed by written notes of key comments. From the immediate arts community, Lewis Biggs (Director of Liverpool Biennial of Contemporary Art), Laurie Peake (Head of Public Sculpture and Engagement, Liverpool Biennial) and Sara-Jayne Parsons (Chief Curator, Bluecoat Gallery) provide encouraging support in the early stages of developing the ACE funding application for *Just wait for me* (2012-13). During their independent studio visits, we discuss the merits of a large-scale figurative public sculpture derived from the small *plasteline statuettes* (Part 1 Plates 2-16, 99-119). These statuettes are of young people in various stages of *waiting*: standing, sitting and shape-shifting. Both Peake and Biggs praise the uniqueness of the statuettes, their depiction of character and their fluidity and flow. Peake adds that “there are lots of interesting interactive street furniture around but I think these statuettes are far more interesting. Central Park and the people of Wallasey deserve something of this quality.”<sup>14</sup> These studio visits from high-ranking professionals, and the positive responses to the ongoing research, give me huge confidence to continue on that path.

### **1.4 Technology of making – tools of the research.**

In the afterword to the *Thinking through art* (2005) compendium of essays



by American and UK artists and researchers, James Elkins notes that a significant amount of art research is still too focused on conceptualisation of the research outcomes. Elkins urges studio art researchers to “address the day-to-day experience of making”<sup>15</sup> by being attentive and foregrounding the methods, knacks, skills and ‘feel of making’ in the studio. This next section provides insight into this day-to-day experience in which I articulate the feel of making with what Benedetto Croce describes as “the single reality of concrete spiritual production, which is all soul just because it is all body.”<sup>16</sup>

#### **1.4.1 Hands as primary tools of making.**

The primary tools of my research are fingers and hands. They are used just as vocal chords and facial muscles form sounds and words in the act of speaking. Staying with this analogy and following poet and author Heinrich von Kleist’s influential essay on the gradual construction of thoughts during speech, the hands in the act of modelling are carrying out the gradual formulation of thought.<sup>17</sup> The primary materials of my research are clay, wax and oil-based sculpting clay plasteline; the key processes are modelling, firing and casting. The shaping, pushing and pulling of plastic materials holds the artist’s attention in the constant movement between an *Ahnung* (inkling) and empathy for the moment at hand. This technology of making by/with the hand is imbedded in the bodily experience of touching, pushing, pulling, stroking, caressing, hitting, squeezing, squashing, padding, poking, cutting, scratching and trampling. Clay is earth, and a material that, according to Genesis, had the most profound impact on the history of mankind. Historian Giorgio Vasari proposes “the material in which God worked to fashion man was a lump of clay.”<sup>18</sup> God modelled us in his own image and animated us by breathing life into the clay figure. This clay figure of Adam then begins his own independent and disobedient life. The shaping of a lump of clay in the image of the other, a process that requires empathy, the breathing of life into the clay and the naming of the sculpted clay ‘Adam’, concludes with the dangerous moment when the sculpted object takes on a life of its own.

Mark Manders considers the sculptural process in the studio as having parallels with the above sequence of events. He chooses clay when making

figurative work and, perhaps in acknowledgement of the creation myth of Genesis, declares it as the most basic and natural material to use. Based in the Netherlands, a country without mountains or rocks but with clay-rich soil readily available, Manders has easy access to clay and it appeals to him because of its low monetary value and commonplace status. Irrespective of whether the clay is later fired or cast in a different material, Manders paints his sculpture to look as if they are in *wet clay*. “I ended up painting the sculpture to look like it was made of wet clay. For this reason, it exhibits an extreme, vulnerable nakedness, and it seems as if you could just press your fingers into it at any time ..... it’s of no importance whatsoever that I had to fire the sculpture in the kiln, then cast it in bronze, and finally paint it to look like wet clay. I don’t want to use my material symbolically but in a more actual and direct way.”<sup>19</sup> He observes how the movement of an arm in one of his figures seems to instill the figure with life. His work mimics the non-petrified and more fragile state of the material that is clay.

Having previously referenced the kneading hands of my mother as *ur*-experience in relation to making, the malleability and accessibility of clay takes on centrality in my work too. I use it as the most appropriate material for my sculpture. For the smaller maquettes, I favoured the bright yellow Pelikan Nakiplast wax and plasteline since both have much finer particle sizes and do not dry. On smaller scale works such as those of 10-20cm height, clay dries very quickly and thin edges are prone to break off. How the change of materials alters the surface of the forms will be discussed in relation to a specific selection of works in 1.5.

#### **1.4.2 The temple and the forecourt.**

Whilst the plasticity of the materials seems at first glance extremely suited to a free flowing improvisation, there are two interlocking forces at work in the studio. Wind uses the metaphor of *the temple and forecourt* in discussing artistic production.<sup>20</sup> Croce also distinguishes between the pre- and post-production reflection and “the single reality of concrete spiritual production.”<sup>21</sup> Both agree that whilst artists have a plan or framework of ideas, the actual making and bringing to life is a less straightforward process. Wind uses the metaphor of the forecourt to describe the pre- and postproduction planning and organisation. The forecourt encompasses the

decision-making process that takes place prior to commencing his/her work, when the artist makes a work plan and decides on the tools and techniques. The forecourt also includes any discussions and negotiations with commissioners, art dealers and critics. Within this space, the choices the artist makes are not arbitrary but always in full knowledge of the plasticity of the materials and processes available. It is in the forecourt that the will of the artist is at work in regard to point of departures, scale and material, all parts of the general framework of ideas, including when the work is ready to be released into the world and when it should be withheld. In the forecourt, all planning and preparation of materials and vague notions of 'what is going to happen' take place.

In the development of the larger outdoor sculpture such as *Just wait for me* (2012-13), the forecourt would contain an implicit understanding of logistics such as transportation, administration, organisation, weather considerations, risk assessments including potential vandalism and public health and safety. There is also fund-raising, liaising with partners and fabricators, press and publicity, the making of measurements, armatures and producing scale models. In the forecourt, source material including drawings and photographs are gathered, armatures made, materials ordered, clay rolled out, overall dimensions mapped out and colour tests made. It also contains the afore-mentioned tacit decisions and experiential knowledge around materials' inert properties, including the crucial shrinkage of clay, an awareness of environmental factors affecting drying times, understanding of gravitational pull and sensibility around mass, proportions and light. The actual work on the other hand, that is the gradual formulation of thought in the process of making with the hands, takes place in the temple, and it is within the temple that the statue "gains through its sensuous fidelity something of the power and personality of that of which it is a model."<sup>22</sup> Within the temple and during the act of making, the will of the artist is suspended. It is replaced by a mental and physical act of empathy, of a going along with or aligning oneself with the growing shape. It is a losing of oneself in that shape to a degree where the boundaries between subject and object, touch and being touched, perceiver and perceived are dissolved. When I am absorbed in the other, I become one with the other by losing myself within it, when the *I* becomes *willenlos* (non-contrived) and loses its self-awareness. There are moments during the process of making in which I invest the lump of clay with the belief that the clay will become a statue of a young person and fulfill the vague image I have in my

head. As the clay is rolled and pushed into approximate shape, the shape starts 'talking back' and 'demands' or 'tells me' where I need to add a bit and take away a bit until it is 'right'. 1.5 will further articulate these material interferences and their impact on the overall appearance of the work. Returning to Genesis, it is clear that the shaping of the clay requires some form of image, an inner image and experience of features and characteristics of, within this research, young people. The moment where 'inner image' and outer realisation in the lump of clay meet satisfactorily slips into the moment of animation. The sculpted figure of an adolescent girl or boy assumes a life of his/her own, confirmed by the naming process (titling), which also acknowledges the completed creation as *the other*. At that moment the work is ready to be released, to be photographed, exhibited and critically evaluated.

### 1.4.3 Drawings in the forecourt

Having mentioned, that the forecourt includes work plans, this selection of my drawings (Figs. 6-23) are included uncommented, demonstrating the inkling of emerging ideas prior to the making.



Fig. 6 *Untitled drawing* (2012). Image by Brigitte Jurack.



Fig. 7 *Untitled drawing* (2011). Image by Brigitte Jurack.



Fig. 8 *Untitled drawing* (2014). Image by Brigitte Jurack.



Fig. 9 *Untitled drawing* (2011). Image by Brigitte Jurack.



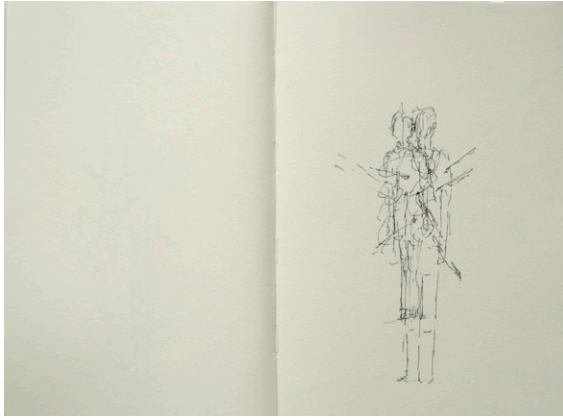

Fig. 10 *Untitled drawing* (2011). Image by Brigitte Jurack.



Fig. 11 *Untitled drawing* (2015). Image by Brigitte Jurack.

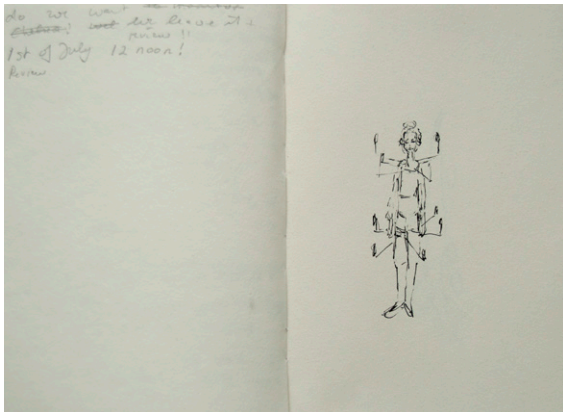

Fig. 12 *Untitled drawing* (2011). Image by Brigitte Jurack..

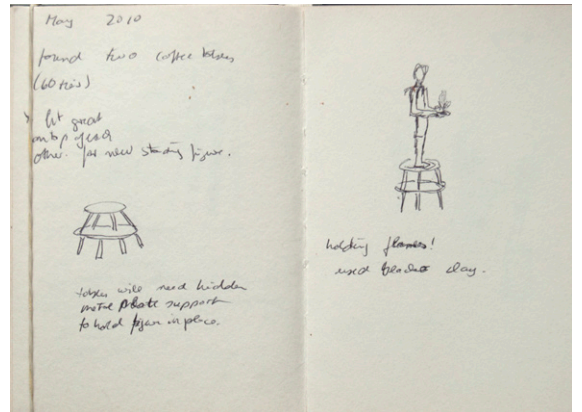

Fig. 13 *Untitled drawing* (2011). Image by Brigitte Jurack.

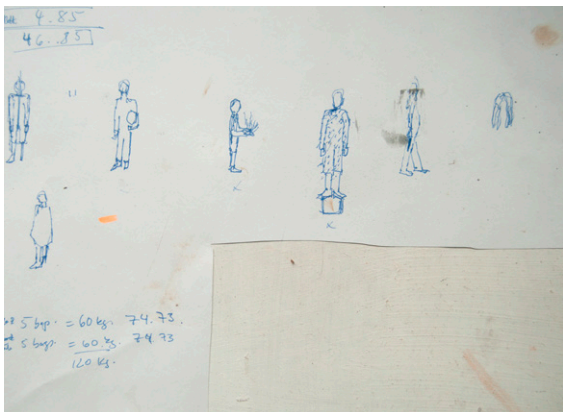

Fig. 14 *Untitled drawing* (2009). Image by Brigitte Jurack.

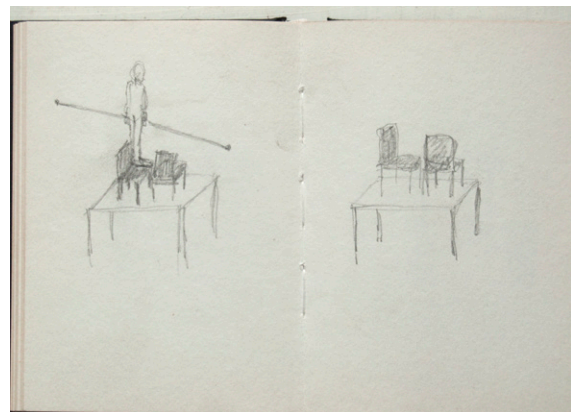

Fig. 15 *Untitled drawing* (2009). Image by Brigitte Jurack.

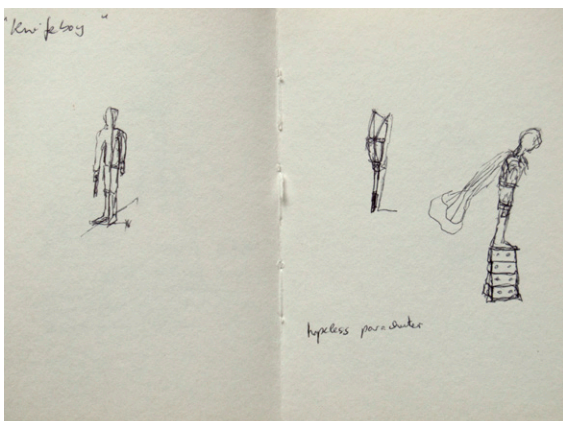

Fig. 16 *Untitled drawing* (2009). Image by Brigitte Jurack.

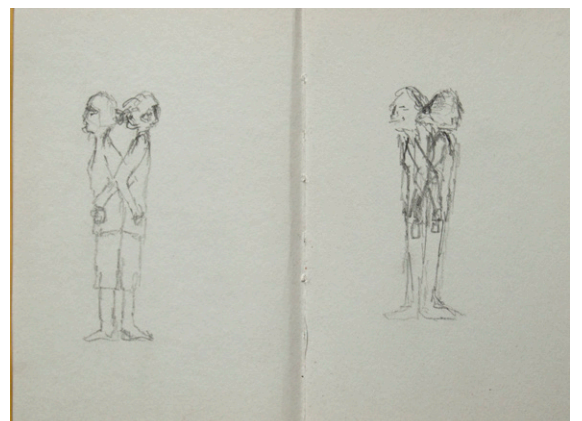

Fig. 17 *Untitled drawing* (2009). Image by Brigitte Jurack.



Fig. 18 *Untitled drawing* (2014). Image by Brigitte Jurack.

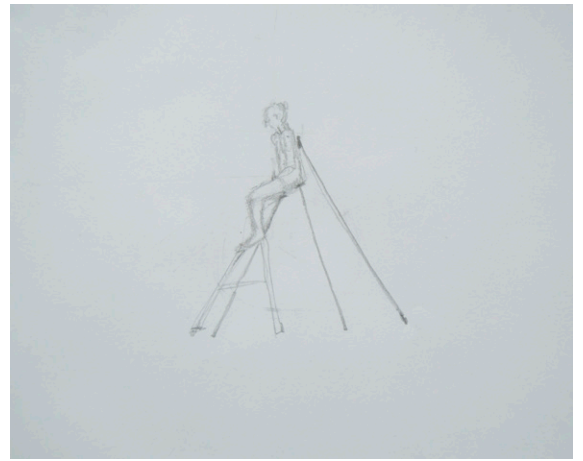

Fig. 19 *Untitled drawing* (2011). Image by Brigitte Jurack.

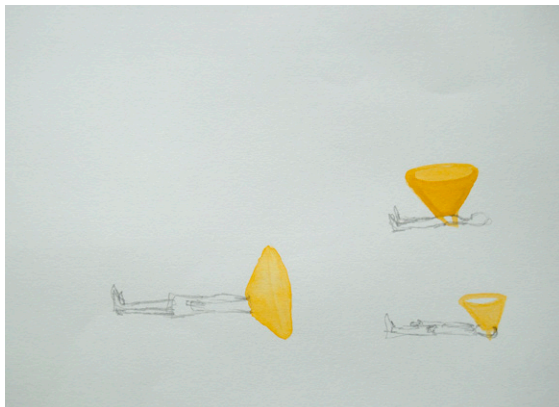

Fig. 20 *Untitled drawing* (2011). Image by Brigitte Jurack.

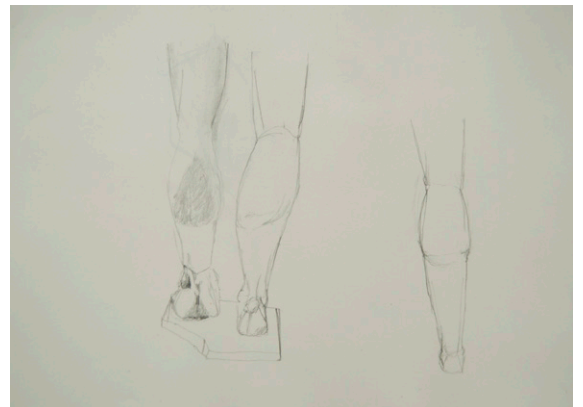

Fig. 21 *Untitled drawing* (2011). Image by Brigitte Jurack.



Fig. 22 *Untitled drawing* (2011). Image by Brigitte Jurack.

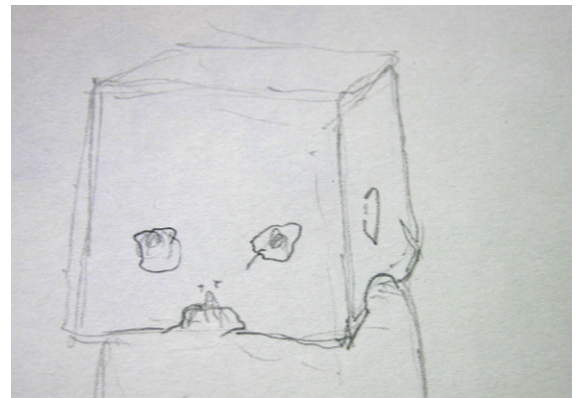

Fig. 23 *Untitled drawing* (2008). Image by Brigitte Jurack.



## 1.5 Sculptural processes relating to modelling and casting.

Having considered the visual stimuli and physicality of the studio and the dialogues within, the possibility of working simultaneously on more than one figure, the relationship between planned and non-contrived work in the studio, this section will concentrate on the reflective interferences caused by the sculptural processes themselves. I will do this through sampling work in far greater detail, dividing my overall sculptural processes into four sections based on different raw materials. All of this sculpture is illustrated in Part 1 and interpreted in Chapter 3.

### 1.5.1 Modelling in plasteline.

Artist Bridget Riley differentiates between working periods in which “the ground is stable and where one can exploit, develop, tool if you like, and those periods when a radical re-orientation is necessary and the basis has to shift.”<sup>23</sup> The radical re-orientation of my works commenced in Athens and continued in Oxtou and was caused by the nature of the studio environment, available time and access to firing facilities. The properties of a particular material, NSP plasteline, also had a profound effect during the early stages of my studio research and *Just wait for me* (2012-13) as public sculpture would not have emerged without plasteline. Originally introduced in 1993 and developed to eliminate the sulphur filler in professional sculpting clay, NSP sulphur-free plasteline by Chavant is oil-based and has no shrinkage. It is made of the finest ballclay, meaning no grains or impurities, and is ideal for small-scale modelling and repairing towards casting in a more durable material. It proves a perfect medium for me to work with and using it for the first time in the Athens studio I quickly discover that it has no internal strength. It therefore requires an inner support structure, such as wire, even on a 10cm scale with the maximum statuette produced being 18cm high. Despite it being oil-based, the plasticity of the material does shift with temperature. In the extreme case, such as holding a heatgun to it, it melts and drips. Only through the heat generated by hand movement does the material actually become malleable, reverting back to a more stable state at room temperature. The plasticity of the material at 26/28°C, combined with the wire support structure, affords me a freedom and fluidity I had not experienced with clay. Working on this scale and being very close to the forms, one single push of the thumb makes a coat, a leg or a hood and a single cut with the tip of a knife

creates cavernous shadows. This is liberating and one work flows from the previous. It enables me to become flippant. Sculpture takes minutes rather than weeks.



Fig. 24 Willem de Kooning *Clamdigger* (1972). Image from <https://tinyurl.com/zqs4335>.

Whilst producing the *plasteline statuettes* (Part 1 plates 2-16) in Athens I am aware of the daily procession of protesting young people lining the streets. The nature of the plasteline means I do not worry about centres of gravity nor heavy sections falling off or splitting. Edges become thinner, heads morph and the ideas of a statue of a twenty-first century youth first enter my head. Attaching each one to a little plaster plinth, the plasteline figures become equivalent to the kouroi (Figs. 50-52) discussed in the next Chapter that once lined the winding path up to the Acropolis. In those small studios in Athens and Oxton, I begin to wonder how the flux and fluidity of plasteline on this scale might be enlarged for a public artwork. Which tools and materials would allow a magnified equivalent of the push of a thumb or the speed and shiftiness of the sculpting action? Which material would best say fragility? Willem De Kooning's *Clamdigger* (1972, Fig. 24) and one of the pieces discussed in the next chapter, Rebecca Warren's *Girl 13* (2003, Fig. 38), have some of that shiftiness. Both are originally made in clay, they capture the notion of an ever-shifting and changing body without the need for overtly descriptive modelled surfaces. I firstly consider a mechanical upscaling of the work but following discussions with Castle Foundry, it becomes evident that these maquettes are too small and soft to use with the mechanical Pantograph scaling tool. For the alternative method, digital scanning, the statuettes contain too many deep and complex undercuts and overhangs that could not be read by the digital scanning process and that would lead to incomplete data with large 'holes.' Instead, I rethink my studio environment and production processes, as discussed in detail in 1.5.3 and 1.5.4.

### 1.5.2 Modelling in clay and firing: ceramic.

The two-figure sculpture *Waiting* (2009, Part 1 Plates 25-30) is made out of clay fired to stoneware. It emerges from a period during which one work immediately generates the next and, as artist Michael Craig-Martin describes this momentum,



“one work realises the possibility of another.”<sup>24</sup> In this section I take this work as an example of modelling in clay for firing to articulate the hitherto silent reflective processes stored within the actual process of making. In the previous section I considered the losing of the *I* in the process of making. Riley asks “can you plan a piece of work, a painting in bed: think it through so to speak? .... although one longs to use one’s intellect as such, one finds that one cannot do so in a way one normally does. What is in that way viable turns out to be beside the point. It seems to be less a question of successive thinking than instantaneous response.”<sup>25</sup> Whilst she is exclusively discussing painting, I am proposing that her notion of instantaneous response is equally applicable to the sculptural process.

Thus ‘having a plan’ for a piece of work is often based on habitual preferences and is necessary but at the same time ‘beside the point.’ This plan may include the use of a particular clay for example alongside the rituals of preparing sturdy surfaces, assembling accouterments such as bricks, timber and plastic sheeting, laying out the basic tools of cutting wire, knives and three modelling sticks, mixing the clay with supporting material such as flax, preparing 3.5-4.5cm diameter clay coils up to a week in advance, depending on the weather, and having some measurements and photos for reference. As the instance of making approaches, there emerges a moment that Riley beautifully refers to as “looking through one’s own sight ... a screen or veil between oneself and the external reality ... which is made up of your own practice or habits of seeing.”<sup>26</sup> These habits of seeing relate to distance and the relationship to scale of both the individual surface bump and the surface as a whole. This subtle understanding of distance also refers to the distance of perception and thus impacts on the empirical size of the artwork as a whole and its separate components. However, this is slightly more complicated when planning to work in clay towards a ceramic. Not only is the wet clay moist, malleable, plastic, heavy and temperamental, it also requires a certain adherence to basic structural building techniques. Most notably, it needs to be built up hollow, and the thickness of the material should be similar throughout the entire form at approximately 2-2.5cm.

I work with the heavily medium-to-large molochite grogged white Vingerling hand-building clay (K130 and K134) that has 3-5% green to dry shrinkage and 10-12% firing shrinkage and flax enhanced medium molochite grog clay (Paper Clay, ES 250) that has 5% green to dry and 10% firing shrinkage. The shrinkage

and solidification that occurs during firing has also to be taken into account as this drastically alters the original 'feel' from a soft and living material to something that has been dried out and petrified in the firing, leading to a change of texture, colour and reflective surface qualities. Before commencing *Waiting* (2009, Part 1 Plates 25-30), I know that I want two figures seated with outstretched legs and presented on tables. These tables establish the viewing height for the figures but I need to find ways in which to build in the shrinkage.

Since I start from scratch with coils of clay, I resolve this issues by using two aids. Firstly I photograph a model, my thirteen-year-old daughter, and measure up before mechanically adding 12% to all distances. This acts as a guide as I begin working through my more instantaneous and instinctive responses. Secondly, I squint my eyes and ask myself to imagine the work 12% smaller. That is, not only the totality of the work but each groove, cut, slash or smudge. I begin coiling the posterior first and then simultaneously work upward into the torso and forward into the legs. The first coils that push together on top of the shrink plate set the size and position of the sculpture. A shrink plate is the base for a large clay sculpture, usually made out of the same clay as the sculpture and covered with a cotton cloth and whose main function is to allow movement and pressure of the sculpted clay to be diverted, thus facilitating smooth and even drying throughout air drying and firing stages. At this point my hands, body and mind are entirely focused on pushing and pulling as fast as possible a foot, a leg, a torso into existence in rough approximation.

This initial full-scale sketch is comparable with the first washed outline on an empty canvas. It is something to respond to. Having prepared sufficient coil supply for uninterrupted work, the interaction with the building up, the interconnecting of the coils and the slow release of a form in the process is intensely close up. There is a nervous exciting buzz, since the call and response is so immediate. The clay that is initially coiled like an oval cylinder becomes 'torso' and literally grows out of the hands. At this point I am neither working from drawings nor photographs. The first sketch is a process of externalising and making real what I have rehearsed in my mind and observed when taking the initial photographs of the life model. During the first few days on each sculpture, no reflective distance is possible nor permitted for it needs to be this intensive close-up encounter. I emerge from this rough draft stage, perhaps halfway up the legs or the chest area, and step back for the first time.

This stepping out of the close-up usually coincides with at least one or two nights away from the work. From then onwards, every change is observed and reflected upon by stepping far enough back within the studio but also by stepping away from the work altogether. Riley continues “when you are in the thick of it, it is crucial that you recognize the different demands your work is making as it unfolds. You must be able to judge and criticize yourself.”<sup>27</sup> In the Bootle studio this is an exciting moment since I have lots of viewing space and ample directional light. The work is modelled at the height at which it will be seen. I remain unsure as to the actual size and constantly double-checked my intuitive first sketch with the tape measure. At that time the work is slightly too small in relation to the anticipated shrinkage and I need to expand outward and in height. I add 4cm to one section, using my eye rather than the spacing sticks favoured by some sculptors in the form of matchsticks applied all over the sculpture to illustrate enlargement. It looks right and I proceed to add 4cm all round. This however leads to the original clay walls becoming too thick with the threat of collapsing inwards, meaning that I have to begin carving away from the inside. Around the rib cage, the clay wall gets too thin, caves in and rips. This is amazing as the dark hollow inside becomes visible and at that very moment I understand that I need much deeper incisions throughout the sculpture in order to enhance the potential of light hooking into the surface and creating a stronger interplay between darkness and light.

I have finally understood the secret behind the high collar of *Uta von Naumburg* (mid-13C, Fig. 2) that dramatically hides sections of her chin. The thick collar also provides anchorage for the thin hand by creating a startlingly deep shadow that enhances the sense of fragility as the thin neck and head emerge from behind the shadow. I consider this moment a genuine breakthrough in which I perceive, in the bright sunlit former Technical College in Bootle, the contrast between light and dark enhancing the three-dimensionality but also emerging as one of the key sources of the illusionary ‘aliveness.’ This newfound sense of cutting deeper holes and creating exaggerated overhangs, explicitly evident later in the public work, in turn creates a new challenge. Where am I moving the pictorial naturalism? Am I going to shape ‘jumper’ or ‘jumperness’ – the specific or the general – or am I going to push the clay towards a representation though imitation? *Uta von Naumburg* (mid-13C, Fig. 2) remains on my wall, the statue that first shifts from the general to the idealised specific. Is *Waiting* (2009, Part 1 Plates 25-30) a specific portrait of the model (my

daughter) or am I trying to get to a point that is intrinsically dialectic, seeking to be both general and specific at the same time? Why is it important that I want to make the same thing twice? I will return to some of these questions in Chapter 3 and the Conclusion as I consider the overall *Just wait for me* (2012-13) project and the use of the double figure. These questions arise within the act of making and are answered through the responsive action of the hands and knife in the clay, the pacing in the studio, the crouching down in the corner, the looking, the making of slight changes, the looking again and the continuous altering. A sculpture gradually reaches a stage in which it has presence but is still 'not quite there yet', which means that there is an unresolved aspect. This is where the process of making becomes tricky and to some extent scary. The actual work slows down, for at this point I know what needs changing but also know that with each change I can destroy the aforementioned presence and condemn the work to a much earlier stage. Having arrived at a point in the studio, where the 'it's nearly there' turns into 'it's kind of there' in regard to a wet clay sculpture, also means that the time of making changes draws to a close. The clay is beginning to get too dry, especially at the extremities of the overhangs and the work needs to be moved into the space where the kiln is.

### **1.5.3 Modelling in clay for casting in stone or aluminium.**

I shall now reflect upon the studio development of *Just wait for me* (2012-13) that is permanently located in Central Park in Wallasey. Chapter 4 will describe the context, processes and concepts behind the project whereas this section shall consider it from the perspectives of scale, modelling clay over a metal armature, up-scaling tools, alterations made in the casting stages and finally the polychromatic surfaces. The overall process is illustrated in Part 1 Plates 31-53. Having arrived at the location for the sculpture described in Chapter 4, I need to find a way of working on a larger scale while maintaining the shiftiness of the plasteline figures (Part 1 Plates 2-24) and the dramatic three-dimensionality, inter-figure relations and becoming alive of *Waiting* (2009, Part 1 Plates 25-30). To reflect upon *Just wait for me* (2012-13), it is important to make two statements. Firstly, it should be noted that the decision to create the two piggybacking figures in cast aluminium and the seated girl in cast stone is purely financial within the budget that I raised for the project. That said, the inherent sculptural processes are similar. Secondly,



what follows is a consideration of the interferences and silent reflections within the process of making. It is not purely a technical guide to the technical aspects of molding and casting public art, and more detailed literature on those subjects exists. In this section I shall instead make use of the anecdotal and reflective notes made in my studio at the time.

### **1.5.3.1 Scale.**

Scale in contemporary sculpture is an important issue and the subject of Rachel Well's recent publication.<sup>28</sup> The first key question for me is the simple one: how big do I have to sculpt these figures of young people to make them *appear* life-size in Central Park? Site visits determine that all three figures would be better served on plinths 60-80cm high. At the stakeholder meetings (Part 3, p.90-98) it was decided that raising the statues above ground onto plinth would also make it less likely that the passing public would try to climb on them. Sculptural tradition suggests that one firstly works on a 1:4 scale model that is then scaled up for final work. In this manner, the up-scaling is either done entirely by technicians in foundries using point-by-point digital or analogue technology, or the artist asks for a 'partial' scaling up. That is, the armature is scaled up, but the artist then 'puts the flesh on the bones.' I decide to go for the partial up-scaling as I was not entirely satisfied with the figures in the *Just wait for me model* (Part 1 Plates 40,41) and did not think that a point-by-point up-scaling would solve this problem. On this issue, I agree with Wind's remarks that "the machine treats forms as if they were indifferent to size, although every perceptive sculptor knows that they are not."<sup>29</sup> As such, the 1:4 model constructed in clay over a wireframe and covered in wax is scaled up to include a 10% increase in the overall size of the figures, from 175cm to 192.5cm, to compensate for their raised platform and the various long distance viewing opportunities in Central Park. To reiterate, by this point of my research I have purchased the large Alternator Studio that enables me to work on figures simultaneously with enough viewing distance.

### **1.5.3.2 Starting anew.**

Initially I pack the steel frame with filling material of polystyrene and wire and cover this with clay, tickling out the shape. I find this process entirely different to

those described in 1.5.1 and 1.5.2 as I am trying to replicate the much smaller model rather than starting from scratch with only a vague internal image. The sheer Part and weight of the clay needed also transforms the responsive and intuitive process described previously into laborious work that is void of free flowing responsive modelling or critical looking. Very quickly, the whole sculpture looks terrible. It appears 'knitted', 'pedestrian', dead or, as Panofsky terms it, *gewollt* (forced). Artists know about this and every artist has a different trick to get out of this kind of situation, ranging from total destruction to drastic interventions. With total destruction not an option within a very tight deadline, I opt for drastic intervention. I cover the 1:4 model with a black bin bag as I feel it is confusing me by inviting me to repeatedly look back at it rather than to look forward. I use a large clay-cutting hoop and clay wire to pull most of the clay off the armature. This is an aggressive act and highly liberating. Stripped back and without the burden of cross-referencing, I finally get into the work and begin to think from within the logic of Riley's *instantaneous response*. Rather than re-creating the model in large I am now in a position to make the piggyback sculpture anew. As a result of this, I begin to work more in the round, looking at what I am doing always from great distance, either by bending down or by stepping into the yard. Through this interaction I gain the confidence of becoming flippant and audacious again. The spirit of the plasteline figures of Athens and Oxtan return and the deep cuts initially discovered in *Waiting* (2009, Part 1 Plates 25-30) re-emerge. I become excited again about what I am doing. Riley describes this effortlessly as "working on what I have been doing in the studio without my being aware of it – absently."<sup>30</sup> When this happens, the next day you look at the work not only fresh but somehow as if something new has been understood. It is at that moment I know what I have to change and roughly speaking how to do so.

#### **1.5.3.4 Up-scaling tools.**

Whilst the push of the thumb is enough to articulate a hood or a leg on the maquette scale, and a press of the whole hand is enough to manipulate the surface on the scale of the figures in *Waiting* (2009, Part 1 Plates 25-30), the piggyback figure was too big for the immediacy of the finger and hand to influence the surface. This impacted on the level of pictorial representation in regard to the hoods and jackets of both figures. I want the top figure's hoodie to morph from the side view into

something that resembles the open mouth of a frog. Additionally I want the top figure to be piggybacked in such a way that it could leap over the figure below rather than pulling it down. In this way I appropriate the dynamic *Ephidrismos* groups (c300BC, Figs. 32,33) discussed in Chapter 2 in which the top figure appears to be flying off in her victorious state. The hood is sculpted from two large irregular-shaped slabs of thinly-rolled clay. I then allow gravity to come into play and let the material fall into position. I am thrilled as the deep shadow it casts is truly dramatic.

The opposite however is happening with the bottom figure's hood and torso. For a long time I am building up clay and taking it down. Nothing I do creates the required presence. At one stage I catapult wet clay into the middle section of the figure. This does not work but at least it is a flippant act. I become so angry and desperate that I throw some clay on the floor, remembering the myth of Martin Luther hurling his inkwell at the Devil. I pick up the thrown clay and bingo! The clay has picked up the floor's cracks and grooves and finally begins to appear as unforced as the smudges in the maquettes. I have inadvertently found a technique for creating the surface that is neither 'knitted' nor mannered but which provides the undercuts and irregular structure that catch the light. These concepts of forcedness and stiffness are difficult to convey outside of the silent reflective dialogue within the process of making. I have articulated the manners in which the growing form in the studio is caught between 'the inner image of the artist' and the outer reality talking to each other. This is not a systematic process, since the application of systems would revert the process of responding to visual sensations into a process of (blind) labour (1.5.3.2) with 'knitted' results. Riley adds "Sensations – visual sensations - defy attention, the moment they are focused upon they evaporate; they are extremely elusive things."<sup>31</sup> The engagement with the work has a bite and vitality that is driven by the curiosity towards new sensual experiences. The overall image for the piggyback sculpture, or what art critic and author John Berger terms "the conscious intension and deliberate striving"<sup>32</sup> is for something that incorporates the fluidity and shifting surfaces of the plasteline figures, both those made by myself and by the young people during the workshops described in Chapter 4. I want something like a leaping frog, a shiftiness, a change of identity, cockiness, laxness, joy and showing off. I am seeking surfaces that create the illusion of liveliness, a kind of becoming and the sensuous encounter I first feel during the making of *Waiting* (2009, Part 1 Plates 25-30).

### 1.5.3.5 Casting shocks.

With the clay figures complete, decisions have to be made on final materials. The budget does not permit casting in bronze and as a result aluminum becomes the only viable alternative for the piggybacking figures. The seated figure, being much simpler from a structural point of view, is cast in water-based resin Jesmonite AC730 silver grey granite, a composite material known as cast stone. I contract Castle Foundry, highly experienced in producing for artists, to undertake the casting of the piggybackers. I pay them to make the molds, wax master, aluminum cast and to deliver and install the work on site.

After the wax master is assembled it becomes clear that a structural engineer would be required to provide drawings and calculations in regard to load bearing and wind resistance. Castle Foundry have reservations about the thinness of the ankles, the top-heavy composition and the unsupervised nature of the Central Park site. Following structural engineering calculations (Part 3, p74-85) I increase the width of the ankles by 5cm to allow for a 2.5cm internal Corteen steel support to be inserted. Before signing off the wax for casting, I notice that part of the face of one of the figures and the deep hood has collapsed when cast in wax. I spend considerable time trying to rebuild the face whilst the figure is lying down. The deep cuts in the eye sockets have also been flattened out in the molding and wax casting and need re-constructing. This is not easy, since the eyes were initially modelled standing up with me looking up towards the face. It is also technically challenging since the thin ridges of wax I create would potentially fall off in the investment molding again. I include this reflection on the time in the Foundry as an important part of the process that can be traced back to seeing the high collar of *Uta von Naumburg* (mid-13C, Fig. 2) and the undercuts in the Bootle studio. In many senses, modelling for casting in aluminum or stone is a much freer process than modelling for ceramic. Issues around gravity and load bearing are resolved through heavy-duty invisible inner steel armature and problems of weight, sagging or collapsing clay are thus non-existent. The interferences in this making process are mainly caused by issues around scale and up-scaling of the whole sculpture but also of the individual mark and subsequent deep undercuts, that have to be made more shallow for the mold making, or which are on some occasions ripped off when the silicone rubber is removed.



#### 1.5.4 Polychromatic surfaces on cast forms.

I have previously touched upon the change in colour and light reflective qualities of clay through the firing process. This section will focus on the hitherto silent reflections in relation to the colouring of *Just wait for me* (2012-13). I have insisted that 'the image runs ahead' as it finds form through my hands and the firing and casting processes change these formulations significantly; pores close, wet becomes dry, soft becomes still and hues shift. Chris Butler, director of Castle Foundry, openly states that bronze gets better with age but cast aluminium gets worse as it oxidises into a dead dark light absorbent grey. My decision to go for bright colours for the sculpture is taken with this knowledge and also in relation to the specific site, its immediate surroundings and the poor light reflective quality of untreated aluminium.

The bright yellow wax figures (Part 1 Plates 99-119) and the positive relationship young people in workshops had with the yellow wax, suggest to me that without colour this public sculpture will not fare well. I plan a reduced palette of two colours for the trousers and hoodies leaving the face, feet and hands in the material colour. When I see the cast aluminium for the first time it becomes clear that this is not an option. The surface is far too dull and does not reflect sufficient light. In fact, oxidised aluminium turns out to be one of the deadest surfaces I have ever seen and comparable to the encounter with the mummies mentioned in 1.2.3. Sandblasted and cleaned, the aluminium oxidises immediately and is a darkish grey. All the blobs, smudges and splatters of clay appear copied in aluminium. Unfortunately some ridges around the eyes have snapped off. I had spent so long on the eyes yet now they were completely dead, lifeless and blind. They require complete reworking using a combination of power drills, welding seams and resin-aluminium composite. Reconstructions completed, I now have the task of bringing this petrified dead surface of the sculpture to life. Whilst the deep cuts, highlights, crevasses and grooves created in the clay enable the light to animate the surface, the light is just simply absorbed and muffled in the dull grey. I have no tacit knowledge on how or where to begin with the application of colour. I know that patination, though not an option due to financial constraints, would create a sense of fusion between colour and form that would be very difficult to achieve through painting. Sculptor Juan Muñoz's double bronze figure *Piggy back* (1996, Fig. 25-26) is patinated in

monochrome mustard yellow and emits a subtle glow that leaves the surface porous and susceptible to changing atmospheric conditions.

Stefan Balkenhol's few bronze casts such as *Kniender Mann* (2012, Fig. 27) are also patinated and mimic his polychromatic wood sculpture, leaving the base tone of the material before applying colour only to highlight lips, eyes, hairline and clothes. Other artists discussed in Chapter 2 including Duane Hanson, John Davies and the Chapman Brothers apply colour within the resin to achieve hyper realistic surfaces. For *Just wait for me* (2012-13), marine paint with high levels of weather and UV-resistance and a lifespan in excess of fifteen years becomes the best solution. The downside of this industrial paint is its high resin Polyurethane content required to prevent oxidization of the aluminium. Three coats of pale grey primer make the surface appear even flatter since the resin has sealed all the rough surface pores. My sculpture approaches total death. I am extremely disappointed, but with no turning back I push on. I entrust all my faith in the colours with some consideration towards realism. Let us have a maroon hoodie, grey tracksuit bottoms, blue-ish trousers and white-ish faces. Do I want to paint shoe or shoe-ness? It is back to the specific-versus-general question. During the modelling, the transition between the two hoodies for example is loose and a little undefined, pushed here and there into the clay, yet now I need to make one yellow and one maroon. As I am applying the colour onto the primer, everything becomes too stiff again. The paint dries totally flat and the strip lights in Castle Foundry do not counter this appearance. I am devastated. The sculpture looks deader and deader with each passing hour. I revisit my studio wall and the pinboards. I recall Balkenhol's sculpture from Kassel, *Man in the tower* (2006, Fig. 28), that is more what I was hoping to achieve, but unlike those patinated surfaces, marine paint is not absorbed in the cast aluminium. It dries on top.

I take an enforced break at this point despite deadlines. I travel to Porto and Lisbon and this transpires to be exactly the right decision. I am absolutely thrilled by ceramic walls and a set of polychromatic wooden statues. My mind plays over the piggybackers. I know something is wrong and that the colours do not work but have no idea yet how to remedy it. Upon my return, I try mixing two colours together, wondering whether it is a problem of the tones or the choice of actual colours I had bought. I order two more, of really red and really blue. I am faced with the situation

that the work looks unsatisfactory painted. I have nothing to lose. In a grand gesture, I mix very bright red, thin it down and apply it with a very large brush over the yellow hoodie. I quickly grab a rag and dab it off. The very fluid red runs into the crevasses and settles in puddles. With the rag, I swiftly dab off larger areas of the surface, but leave the red nestling in all the uneven surfaces. I step off the ladder and move back a few paces. I turn around to look and smile with relief. The sculpture has come back again. It is alive! Using this over-painting technique, there is light, nuance, difference and the surface has become animated. I have achieved the interplay between the bright yellow ground and the darker but translucent red top, creating precisely the orange I am after (Part 1 Plates 52,53), vibrant and shimmering rather than still and static. This moment is the 'it is working' moment and happens quite literally in an instant. The simple act of using the thick brush of thinned down red paint brings the sculpture into *the now* and gives it presence. After three weeks of painting



Fig. 25 Juan Muñoz *Piggyback with Knife* (2001), bronze with yellow patina. Image from <https://tinyurl.com/lclpa7f>.



Fig. 26 Juan Muñoz *Piggyback with Knife* (2001). Courtesy Marian Goodman Gallery, New York. Image from <https://tinyurl.com/zhkj2et>.



Fig. 27 Stefan Balkenhol *Kniender Mann* (2012). Image from <https://tinyurl.com/z34n4r8>.



Fig. 28 Stefan Balkenhol *Man in the tower* (2006). Image from <https://tinyurl.com/zg3wamz>.

the sculpture without any sense of it improving, the thinned layered paint finally adds the required impact. I want to say hands, but not fingernails. I want to say lips (Part 1 Plate 48) but without clearing up too many of the loose borders of the original pushed clay. I have finally found the delicate negotiation between 'saying too much' and 'not saying enough'.

In summary, the size and lighting of the particular studio had significant impact on my ability to work on two figures at the same time – the beginning of thinking

about 'the double' - and the recognition that undercuts and crevisses in the clay create shadows that enhance the illusion of 'coming alive.' I have discussed the differing materials and their aesthetic impact on varyingly-scaled works and my reflections on the trials and tribulations with colour and upscaling demonstrated the challenges of reimagining a piece of work after it is returned from an external fabricator.

Focusing on these processes, this chapter has articulated the hitherto implicit dialogues that underpin the formulation of thought in the process of making. Applying Wind's metaphor of the temple and the forecourt, I have demonstrated how making shifts between intuition and reflection. The 'messy' process of studio work is supported by a priori knowledge and the recall of experiences of encounters with other sculpture through the restaged pinboards I shall now discuss in greater detail.

## Endnotes

1 Elkins, J., *Afterword: On Beyond Research and New Knowledge*, in *Thinking Through Art: Reflections on Art As Research*, 2005, edited by Katy Macleod and Lin Holdridge, Routledge, London, p264.

2 *It is disappointing that we seem to observe the world as through a membrane*, interview with Mark Manders, 2001, Arnhem, online, available at: <https://tinyurl.com/zyuo4ph> [accessed 13.2.2017].

3 *The Absence of Mark Manders*, 1994, artist's statement, online, available at: <https://tinyurl.com/zyuo4ph> [accessed 13.2.2017].

4 Panofsky, E., *Die Deutsche Plastik des Elften bis Dreizehnten Jahrhunderts*, 1924, Kurt Wolff Verlag, München, p66.

5 *It is disappointing that we seem to observe the world as through a membrane*, interview with Mark Manders, 2001, Arnhem, online, available at: <https://tinyurl.com/zyuo4ph> [accessed 13.2.2017].

6 Belting, H., *An Anthropology of Images*, Princeton & Oxford, Princeton University Press, New Jersey, 2011, p3.

7 *ibid* p3.

8 *ibid* p3.

9 Taussig, M., *Mimesis and Alterity: A Particular History of the Senses: A Particular Study of the Senses*, 1993, Routledge, Oxford, p2.

10 Belting, p89.



- 11 Blom, I., *Media Animism: Rachel Harrison's Living Images in Art and Subjecthood in The Return of the Human Figure in Semiocapitalism*, 2011, ed. Isabelle Graw, Daniel Birnbaum, Nikolaus Hirsch, Sternberg Press, Berlin, p70.
- 12 *ibid* p70.
- 13 Warnke, M., *Flüchtling ohne Schlepper. Aus dem Bildindex zur politischen Ikonographie*, *Zeitschrift für Ideengeschichte Idee*, 2016, Heft XIII/4 Winter, online, available at: <https://tinyurl.com/kaygef3> [accessed 13.2.2017].
- 14 Laurie Peake comment during studio visit, 2012.
- 15 Elkins, p246.
- 16 Croce, B., *Criticism and History of the Figurative Arts: The Present Phase*, 1919 cited in *Philosophy, Poetry, History An Anthology of Essays by Benedetto Croce*, 1966, translated and introduced by Cecil Spigge, London: Oxford University Press, p362.
- 17 von Kleist, H., *On the Marionette Theatre*, 1994, cited in *Essays on Dolls*, 1994, trans. Idris Parry, Penguin Books, London.
- 18 Vasari, G., *Lives of the Artists (1568)*, 1965, Vol.1, trans. George Bull, Penguin Books, London, p2.
- 19 *Room, Constructed to Provide Persistent Absence*, interview with Mark Manders, 2002, Toronto, online, available at: <https://tinyurl.com/zyuo4ph> [accessed 13.2.2017].
- 20 Wind, E., *Art and Anarchy*, 1963, Faber and Faber, London, p90.
- 21 Croce, p362.
- 22 Taussig, p16.
- 23 Riley, B., *Dialogues in Art*, Robert Kudielka (ed.), 2003, Thames & Hudson, London, p58.
- 24 *ibid* p58.
- 25 *ibid* p40.
- 26 *ibid* p46.
- 27 *ibid* p59.
- 28 Wells, R., *Scale in Contemporary Sculpture: Enlargement, Miniaturisation and the Life-size*, 2013, Ashgate, Surrey.
- 29 Wind, p66.
- 30 Riley, p2.
- 31 *ibid* p78.
- 32 Berger, J., *Permanent Red: Essays in Seeing*, new edition 1979, reprint 1981, Writers and Readers Publishing Cooperative, London, p65.



## Chapter 2 - Pinboards tracing a historical context.

Having concentrated on the silent dialogues that take place with the malleable material in the studio, Chapter 2 zooms out from the specific problems associated with making. I do so in order to map out the wider landscape of the representation of youth through sculpture and to identify three recurring sculptural motifs. In this chapter I will deploy the model of Aby Warburg's sixty-three *Bildertafeln* (translated as *picture panels* or *pinboards*) entitled *Mnemosyne Atlas* (1924-29, Fig. 29), to form the basis of this exploration into recurring motifs. On a visual level, Warburg's picture panels are not dissimilar to my studio wall on which I recreate three pinboards (Figs. 30, 49, 68) of postcards, photocopies, sketches and photographs.



Fig. 29 Aby Warburg *Mnemosyne Atlas* (1924-29, unfinished). Image from <https://tinyurl.com/zkjervm>.

*Mnemosyne Atlas* (1924-29, Fig. 29) is an attempt at visually mapping out “how images of great symbolic, intellectual, and emotional power emerge in Western antiquity and then reappear and are reanimated in the art and cosmology of later times and places.”<sup>1</sup> Warburg “believed that these symbolic images, when juxtaposed and then placed in sequence, could foster immediate, synoptic insights into the afterlife of pathos-charged images depicting what he dubbed *bewegtes Leben* (*life in motion* or *animated life*).”<sup>2</sup> The wooden boards create intuitive *Denkräume* (thought-spaces) that allow for the development of themes that Warburg supplements with interpretive material.

Pinned to my studio wall, the side-by-side reproductions of artworks spanning from antiquity to the present day function as an externalisation of the amassed and

fluid experience contributing to the initially intuitive logic that infiltrates my research. This approach is best described as a continuous silent dialogue between images pinned to a wall and the formulation of thoughts and ideas through clay, plasteline and plaster. At the time of making sculpture in the studio, this silent dialogue takes place between material, hands and observations in the here and now, together with memories of encounters with the artworks discussed in this chapter. My pinboards consist of photographs and small sketches of sculpture that I study in original and online at the Tate (London), Walker Art Gallery (Liverpool), Metropolitan Museum (New York), the British Museum (London), the Art and Architecture Slide Archive (The Courtauld Institute of Art), The Henry Moore Institute (Leeds), the Getty Museum and Archive, the Royal Society of British Sculptors, the Public Monuments and Sculpture Association, VADS (Visual Arts Data Service) and The Decorated School (Faculty of Education, University of Cambridge).

Whilst I argue in 1.1 that the pinboards provided a springboard for thinking and making, for the purpose of clarity I am separating the deeper analysis of them from the interpretation of my own work in Chapters 3 and 4. The sculpture that I produce are the concrete articulations that emerge out of this fluid environment of other sculptural influences and the *exegesis* (critical explanation) of the sculpture is thematically driven by three motifs. These three motifs appear clearly in Greek antiquity and resurface in the representation of youth, both in history and in my work and are:

**Pinboard 1** (Fig. 30)

Motif 1: youth in a state of rehearsing and displaying fitness and readiness through rituals, games, sport and dance.

**Pinboard 2** (Fig. 49)

Motif 2: youth in a state of inwardness and self-absorption.

**Pinboard 3** (Fig. 68)

Motif 3: youth in a state of physical vulnerability.



## 2.1 Pinboard 1 (Fig. 30)

**Motif 1: youth in a state of rehearsing and displaying fitness and readiness through rituals, games, sport and dance.**



Fig. 30 PINBOARD 1: *Photographs on wall of Alternator Studio, 2012- (restaged 2017)*. Image by Brigitte Jurack.

These works are linked by their uses of swings, surfboards, sporting games, school plays, dance and rituals. The statues and statuettes give form to aspects of youth that are distinct from childhood and adulthood. They show youth as a stage where both male and female figures rehearse their fitness. We, the onlookers, stand witness to these rehearsals and as such these statues and statuettes continue to demonstrate the importance and value of the public display of the moment where a child transitions into adolescence and where the adolescent is shown as preparing and being prepared for his/her adulthood. Childhood and the education of the male and female youth in Ancient Greece is well documented by historian Giovanni Levi<sup>3</sup> while historian Claudia Müller's study of the educational role of rituals and cults during the Archaic period cites the Swing Festival (*Aiora*) as a ritual celebrating cleansing and redemption for children and unmarried girls.<sup>4</sup> Watched by adults, their movement through the air as a temporary weightlessness was understood as an act of kicking away bad omens to ensure a healthy and happy year ahead. *Aiora* celebrates children *and* unmarried girls together and swinging is understood as a magical act that provides blessing across the generations.



Fig. 31 *Woman sitting on a swing*, Hagia Triada (450-1300BC), Heraklion Archaeological Museum, Crete, photograph by Brigitte Jurack.



Fig. 32 *Girls Playing Ephedrimos* (ca. 300BC), The Metropolitan Museum of Art, New York. Image from <https://tinyurl.com/zd3sdcx> Rogers Fund, 1907 (07.286.4).

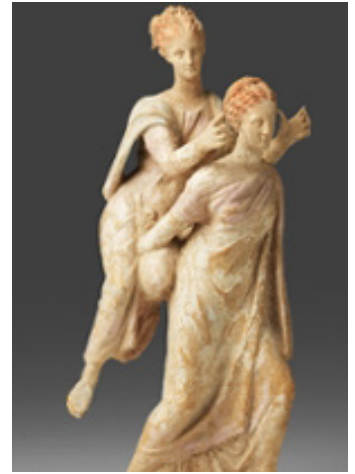

Fig. 33 *Ephedrimos group* (300-250BC), Allard Pierson Museum, Amsterdam, Netherlands. Image from <https://tinyurl.com/hw6hbbp>.

The ancient game of *ephedrimos* (piggybacking) was especially popular among young women and adolescent girls. Images of young males piggybacking do exist but the majority of surviving terracotta statuettes show two late-adolescent girls with billowing white chitons (tunics) during the latter stages of the game in which the winning person is being piggybacked by the loser. *Ephedrimos* groups of girls (c300BC, Figs. 32, 33) show a scene of everyday life with additional symbolic meaning. “The winner in this game, who is carried on the loser’s back, was seen by the ancients as symbolising Eros or Aphrodite ... with the representation of the girls playing ephedrimos also a sign that the winning girl is ... betrothed to be married.”<sup>5</sup> *Ephedrimos* groups (c300BC, Figs. 32, 33) as symbols of fitness and readiness to enter married life and their “erotic and epithalamic associations”<sup>6</sup> might explain why more females are portrayed in these groups and why the motif remains popular, as demonstrated by numerous nineteenth century replicas.

Today, adolescents piggybacking on the beach or at open-air festivals are seen as signs of them enjoying their physical fitness, sexual readiness and independence. Terracotta statuettes from Ancient Greece also depict adolescent girls dancing (300BC, Fig. 34). Many of these were found in Tanagra and became highly desirable objects in nineteenth century Europe. The symbolic value of dance as an expression of control of one’s own body as it transitions from childhood dependency to adolescent independence also becomes form in Edgar Degas’ *Little dancer aged fourteen* (1880-1, Fig, 35) and Duane Hanson’s *Cheerleader* (1998, Fig. 37).<sup>7</sup> Originally shown as a wax sculpture dressed in gauzed tutu,



Fig. 34 Terracotta statuette of a girl dancing (300BC), Metropolitan Museum of Art, New York. Image from <https://tinyurl.com/h6wnw9x>.



Fig. 35 Edgar Degas *Little dancer aged fourteen* (1880–1), Tate Gallery, London. Image from <https://tinyurl.com/zdxwjx5>.



Fig. 36 Ryan Gander *Little Dancer* (2008). Image from <https://tinyurl.com/j374lyx>.

cream coloured bodice, real hair and shoes, the three-quarter life-size *Little dancer aged fourteen* (1880-1, Fig, 35) shows a ballet student at the Paris Opera. The little dancer's chest is covered in a close-fitting bodice, stretched forward by the tightly clasped hands at her back. Her head and chin are directed up and her facial expression appears tense with a gaze directed up and away from that of the viewer. Her controlled and tense pose, together with the wrinkles in her tights, suggests that her independence has been gained through pain, endurance and total body control, in short through achievements in dance. Displayed on a 150cm high plinth at the Glyptotek Stockholm, the girl's independence is magnified though her elevated position, making it impossible for any viewer to meet her gaze.

This elevated isolation has recently been deconstructed in Ryan Gander's appropriation *Little dancer* (2008, Fig. 36). Gander creates further episodes in the dancer's afterlife, taking her off the pedestal and letting her behaviour become increasingly transgressive. Hanson's *Cheerleader* (1998, Fig. 37) epitomises cultural theorist Angela McRobbie's analysis of dance and fantasies of achievement in regard to the transition between childhood and adolescents. This life-size statue of an adolescent girl in mini skirt and tricot, stands still with her hands loosely gripping the pompom as if hesitant or unsure of herself as a cheerleader. With heavy make-up and coiffured hair,



Fig. 37 Duane Hanson *Cheerleader* (1988), Collection of Mrs. Duane Hanson. © Estate of Duane Hanson/Licensed by VAGA/New York, NY. Image from <https://tinyurl.com/h2n4r59>.





Fig. 38 Rebecca Warren *Girl 13* (2003), Courtesy Galerie Max Hetzler, Berlin. Image from <https://tinyurl.com/h7evcsa>.

the girl looks much older than her youthful cheerleader outfit suggests. Similar to *Little dancer aged fourteen* (1880-1, Fig. 35), her body and facial expression are tense. The sexual awakening of the *Cheerleader* (1998, Fig. 37) is visualised subtly by her hands framing the crotch, her silky red billowing jacket and red pompom. Her *attributes* (props) are inactive, demonstrating her sexual self-awareness yet simultaneously appearing uncertain about it. Whilst *Cheerleader* (1998, Fig. 37) depicts a sense of waiting, Rebecca Warren's *Girl 13* (2003, Fig. 38) strides boldly with one leg stretched high in the air into a space beyond the supporting board.

With a twig held high in one of her two raised hands, billowing short skirt and right foot on tiptoes at the edge of the board, *Girl 13* (2003, Fig. 38) is taking a giant unsupported leap. Indirectly referring to the movement of a majorette, this statue provides an image of an adolescent girl in full control of her body as it leaps into the space beyond her own physical confinement.

The statues and statuettes of games, rituals and dance demonstrate the fitness and readiness of female adolescents in the increasingly urbanised context of Ancient Greece. For the young male, athletics and other competitive sports, such as wrestling, were prioritised over hunting as a sign of social distinction in an age aspiring to radiance and physical perfection. *Statue of a victorious youth* (300-100BC, Fig. 39) and the *Boy of the bay of Marathon* (*Ephebe of Marathon*) (c340-330BC, Fig. 40) provide images of the athletic, upright and well-toned body of the *ephebe* (in ancient Greece, a young man of between eighteen and twenty) arrested in action. Their attributes such as ball, wreath or palm branch may on occasion be missing, but the outstretched arms and *contrapposto* (forward

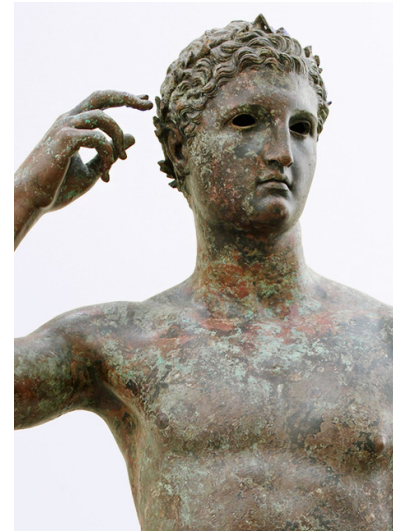

Fig. 39 *Statue of a victorious youth* (300-100BC), J. Paul Getty Museum, Los Angeles, USA. Image from <https://tinyurl.com/h7thrca>.



Fig. 40 *The boy of the bay of Marathon* (c340-330 BC), National Archaeological Museum of Athens, Greece. Image from <https://tinyurl.com/zt9eh5r>.



movement) of their bodies suggest a totally controlled physique celebrating success in sport. *Statue of a victorious youth* (300-100BC, Fig. 39) is one of the few surviving bronze statues of athletic statuary erected by the hundreds at Olympia, Delphi, Nema and Ishhmia, the sites of the Panhellenic Games and in the home cities of the victors. *Boy of the bay of Marathon (Ephebe of Marathon)* (c340-330BC, Fig. 40) is again life-size at 130 cm and shows a *mellephebe* (prepubescent boy). His features are delicate and the positioning of his arms, void of any attributes, has left scholars mystified as to what kind of activity he is engaged in.

The well-ordered life of the Greek city-state expressed itself through the education of its *paidea* (male youth) as guarantors for the city's future. The overarching aim of these educational practices was "to give young men a very precise idea of their role as future citizens."<sup>8</sup> *Statue of a victorious youth* (300-100BC, Fig. 39), with fine facial features, small genitals, delicate neck and slender body was seen as a state of grace and young men in particular were regarded as objects of desire for every citizen. Outstanding achievements in sport were honoured with statues celebrating particular people, however, "the enduring message of monuments representing real people, both political and athletic, would have depended over the years upon familiar, generic character and their inscriptions. The appearance was imaginary, illustrating the ideal, long after the particular would have been forgotten."<sup>9</sup> *Statue of a victorious youth* (300-100BC, Fig. 39) captures the unconquerable grace of the handsome body of late adolescence and *Boy of the bay of Marathon (Ephebe of Marathon)* (c340-330BC, Fig. 40) that of the prepubescent boy and both statues are best read as idealised *honorees* or publicly-rewarded achievers.

The public display of athletic youth at the cusp of entering adulthood reaches new heights in the public statues carved and cast during the Fascist and National Socialist periods in Europe. The Stadio dei Marmi serves in this context as an excellent example, proclaiming a seamless continuity of the Roman movement from Augustus through to Mussolini. Sport as a symbol of fitness and competitive strength is explicitly on public display at the Stadio dei Marmi at the Foro Italico (Foro Mussolini) in Rome, inaugurated

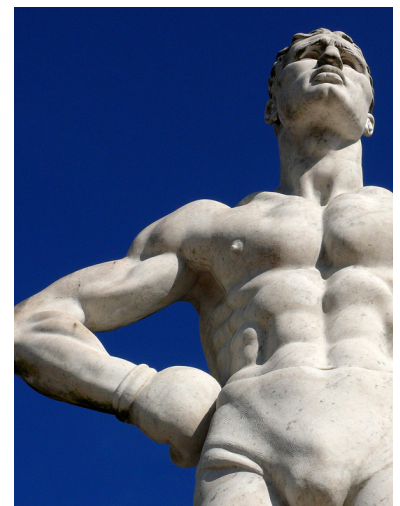

Fig. 41 Statue at Stadio dei Marmi at the Foro Italico (Foro Mussolini) (1932), Rome, Italy. Image from <https://tinyurl.com/jkbwove>.



Fig. 42 Statue at Stadio dei Marmi at the Foro Italico (Foro Mussolini) (1932), Rome, Italy. Image from <https://tinyurl.com/gq5q2by>.

in 1932. Sixty statues rise above the top tier seats of the stadium. They are significantly larger than life-size, dwarfing the spectator and represent young men in relation to various Olympic disciplines. Though appropriating *Statue of a victorious youth* (300-100BC, Fig. 39), the athletes flanking the Stadio dei Marmi (1932, Figs. 41, 42) are super-sized and overpowering in their 'ready-to-win' poses. Thick necks, powerful ankles and strong wrists replace the delicate and vulnerable ankles and wrists of the life-size ephebes. Towering above the spectator, their postures appear arrested at the starting block. They visualise a very different image of youth, one so big and powerful that

it is destined to win on the basis of its super strength. Together with the site, the newly constructed and originally named Mussolini Stadium, the motif of the sporting young male becomes a symbol of a 'new future' and 'new super strong race.' On closer consideration, we begin to question these super strong heroes due to their distasteful political function and exaggerated muscles and proportions more akin to the Incredible Hulk. In reality, they do not embody a standard of appearance and self-presentation that is heroic and simultaneously attainable.

A very different aspect of the value of sport in rehearsing and displaying male and female fitness during adolescence is shown in the two reliefs by artist László



Fig. 43 László (Peter) Peri *Relief of Boys Playing Football* (1951-2), South Lambeth Estate, London, © Historic England. Image from <https://tinyurl.com/hy5nouj>.



Fig. 44 László (Peter) Peri *Folk dancing* (1956), Scraftoft North Primary School, London. Image from <https://tinyurl.com/h37j5v5>.

(Peter) Peri, commissioned during the post-WW2 building programme of new social housing and schools in London. In both instances the social aspect of sport is foregrounded, but site is also crucial in the interpretation of these works. Newly-commissioned social housing for London and the new school building

programme heralded the dawn of a new era of social welfare and aspiration for a healthy and peaceful childhood for those destined to become the stakeholders of the post-war welfare state. Peri's *Relief of boys playing football* (1951-2, Fig. 43) and *Folk dancing* (1956, Fig. 44) depict young people engaged in team activities. The relief figures are shown in action and in relation to the actual environments in which they live and work. *Folk dancing* (1956, Fig. 44) is a large concrete relief on the gable wall of a newly constructed school that shows a combination of three female and three male adolescents. Depicted in movement with one foot off the ground and billowing skirts, the group of six creates an almost heart-shaped formation of symmetric accord, in which males and females mirror each other's movement. The motif of dance emerges as a shared symbol of an independent and harmonious togetherness of



Fig. 45 Duane Hanson *Surfer* (1987), Collection of Mrs. Duane Hanson. © Estate of Duane Hanson/Licensed by VAGA/New York, NY. Image from <https://tinyurl.com/h2n4r59>.



Fig. 46 Duane Hanson *Surfer* (1987), Collection of Mrs. Duane Hanson. © Estate of Duane Hanson/Licensed by VAGA/New York, NY. Image from <https://tinyurl.com/h2n4r59>.

male and female youth. On the walls of the new school it also foregrounds dance as a socially acceptable form of equal and peaceful togetherness of youth. For art historian Anthony Blunt, the simplicity in the “formal arrangement is the exact expression of a psychological situation: the groups are united by play of plane and curve, but

these are supported by a unity of look and feeling.”<sup>10</sup> Peri's works are driven by an inquiry into the sense of the individual, the man and women of the street, in relation to world at large, not only society, but the universe.

Duane Hanson's *Surfer* (1987, Figs. 45-46) returns to the image of the athletic adolescent boy of life-size proportions. Cast from life and dressed only in shorts, the blond teenager is half holding and half leaning against his surfboard. His spare hand is pressed into his side, giving his posture an air of confidence and superiority. He smiles slightly, winningly and his gaze catches that of the viewer. Surfing is a sport that epitomises predominantly male supremacy over the forces of nature through total control of body, mind and tool and is expressed as a sign of



independence of the adolescent male as 'winner.'



Fig. 47 Miroslav Bałka *Souvenir of the First Holy Communion* (1985), Museum of Art, Lodz. Image from <https://tinyurl.com/jfomqf>.

Far less infused with this air of certainty are the statues of adolescent boys in Miroslaw Bałka's *Souvenir of the First Holy Communion* (1985, Fig. 47) and Charles Ray's *School Play* (2014, Fig. 48). The former depicts a significant ritual and the approving role of the adult audience. Religious maturity and independence is celebrated in Catholic communities through the public event of the First Communion that marks the transition from child to young teen. Produced as Bałka's graduation project, the sculpture depicts a life-size figure of a boy, probably between eight and thirteen-years-old, and is made from coloured concrete with a cast short trouser suit.



Fig. 48 Charles Ray *School Play* (2014), © Charles Ray. Image from <https://tinyurl.com/guakcww>.

He stands stiffly next to a small table that is covered with a tablecloth on which rests a photograph of a small child. The boy's right hand is resting on the table, preparing for a souvenir photo to be taken and on his lapel is a heart-shaped red pincushion. The graduation project's presentation was a carefully orchestrated event. Bałka invites his professors to an abandoned house in the suburbs, taking them there by hired bus but making them walk the final kilometre. During this last leg, they are passed by the artist, riding a small bicycle and dressed in a First Communion suit. Upon



entering the house, everyone receives a pin and is invited to insert it into the heart-shaped pincushion. Bałka aims for an artistic maturity with his ritual that is similar to the ceremony itself that confirms religious maturity. Within the sculpture, the image of the child is offset by the image of the boy in his rites of passage suit. The red heart on the lapel that is pricked by the professors, functioning in this instance as the approved adult authorities, suggests the interdependence of two generations and the symbolic pain caused by the process of conforming and confirming.

Ray's *School Play* (2014, Fig. 48) is a life-size statue of a boy of about twelve, dressed in a bed sheet toga. He has a sword in its decorative casing in one of his hands that droops down by his slim body. The statue is modelled and cast in stainless steel and tooling marks are left as an outward manifestation of a not quite formed mind. An indent in the back of the head is intended by Ray as an outward sign of the boy's impenetrable thoughts. The boy's face appears rather blank and out of focus, possibly a reflection of "being there and not being there."<sup>11</sup> The knot at the back of the toga is tied neatly by a caring adult and yet the boy appears distant, leaving the spectator at a loss to what boys at that age are really thinking about. Ray neither mentions the sword nor the fact that the adult spectator sees his/her own reflection in the polished surface of the statue. In relation to the other statues discussed from this first pinboard, the sword and the mirrored surface are highly significant. The boy is holding a theatre prop sword and is rehearsing what it is like to be a Roman warrior. The grown-up viewer of *School Play* (2014, Fig. 48) literally sees him/herself reflected in the statue, spectacularly highlighting ideas of 'projection' and 'imprint' of the older onto the younger protégé.

## 2.2 Pinboard 2 (Fig. 49)

**Motif 2: youth in a state of inwardness and self-absorption.**



Fig. 49 PINBOARD 2: *Photographs on wall of Alternator Studio, 2012- (restaged 2017)*. Image by Brigitte Jurack.

The thread running through Pinboard 2 is the act of being engrossed in an activity that creates a closed circular movement between the figure and its occupation. This engrossment means not meeting the onlooker's gaze nor being present in a seemingly withdrawn absence. The artworks included here give form to an aspect of youth that is distinct from either childhood or adulthood as they show youth as a stage in which young males and females are preoccupied in their own world. This inwardness and self-absorption is fundamentally understood in relation to motion or inner turmoil. It is a motion that turns the onlooker into a perceptive state that "requires an identificatory attention - of an almost hypnotic type - through which an exchange takes place between the subject and the object."<sup>12</sup> The statue itself does not need to illustrate some expressive outward movement but it sets into motion the pulsing of presence and absence and locates empathy at the centre of the maker and those viewing the sculpture.

Ancient Greek culture again provides the initial statues discussed. The sheer number of *kore* (female, Greek for maiden, the plural is *korai*) and *kouros* (male, plural is *kouroi*) is staggering and it has been estimated that there are twenty



Fig. 50 *Kore* (maiden) (c550-540BC), found at Merenda, Attica, National Museum Athens, photograph by Brigitte Jurack.

Fig. 51 *Kouros of Tenea* (560-550BC), Glyptothek Munich, Germany. Image from <https://tinyurl.com/he4vzle>.

thousand in existence. Etymologically relating to the word *koros* (a seedling or shoot of a plant), the statues we know collectively as the kouros type were set up as votive offerings in sanctuaries, markers of Greekness (*sema*) or memorials (*mnema*) in a funerary context. Irrespective of their 'stylistic' development, they all embody the ideology of *kalokagathia* (beautiful goodness) and a heroising sentiment. The *Kouros* (c560-540BC, Figs. 50, 51) at the National Archaeology Museum in Athens and the Glyptothek Munich are excellent examples of these statues of maidens and young men. According to classicist Nigel Spivey, whether these statues represented gods, demi-gods or mortals is less important than the involvement of the viewer, created by their ubiquitous presence in places of worship and sport. Their youthful looks, broad shoulders, small genitals, lack of facial hair and the common pose of the left foot slightly advanced celebrate the body in its prime, "Neither standing nor walking, the *kouros* suggests the perfect 'nimble-footed' or 'swift in knees' (*laipsera gouna*) readiness of the Homeric hero."<sup>13</sup> Their gazes are directed into some distant space, as if present in their physicality but simultaneously absent in their aspirational ideology or god-likeness. People passing these statues in their original sites would have recognised their appropriate dedications to female or male deities, or their significance as memorials of deceased family members. In their new surroundings of museums, these statues continue to instigate the aforementioned pulsing of presence and absence.

Archaeologist and art historian Gisela Richter refers to this quality as aloofness and universality in relation to statues from the second half of the fifth century BC that have a "grandeur and idealism which remove them from nature"<sup>14</sup>

with an impersonality that makes them great. Not denying their impersonality, Spivey shifts the focus in the reception history by emphasising their usage in Ancient Greek culture. The statues are sculptural contributions to a heroic and heroising culture. They “set the physical tone for a practice of emulation and aspiration”<sup>15</sup> and show standards of appearance and self-presentation that are larger than life and at the same time attainable. In this respect, the typical and desirable is set against the individual and the general against the particular that “gives us a peculiar sense of

exhilaration because it can translate us from the narrow personal plane to an impersonal one.”<sup>16</sup>



Fig. 52 *Youth (Kritios or Kritian boy)* (c480 BC), Acropolis Museum, Athens. Image from <https://tinyurl.com/juddnwl>.

*Youth (Kritios or Kritian Boy)* (c480BC, Fig. 52) exists at the end of the ubiquitous use of the kouros type and before the ‘action statues’ made possible by the development of bronze working techniques that allow for more expressive forms of modelling. It is displayed in the new Acropolis Museum and as Spivey reminds us, “it is easy to forget, that this statue once possessed a proper identity ... a simple legend to the statue, which may in aesthetic terms, explain why the figure of the boy is at once both restrained and assertive. He is an

athletic victor, hence proud; dedicating his image to Athena, hence grateful.”<sup>17</sup> The cleaned and slightly smaller than life-size marble in the colour of warm white sand is mounted on a plinth that places the viewer about a head below the boy’s gaze. His inlaid eyes are missing but his gaze is directed towards the far distance. *Youth (Kritios or Kritian Boy)* (c480BC, Fig. 52) is a figure celebrated for “his taut, but not over-muscular body, a pert bottom, a clean jaw and a rather moody set of features”<sup>18</sup> that conforms to norms of male beauty assessed as part of the regular Panathenian games. *Youth (Kritios or Kritian Boy)* (c480BC, Fig. 52) is based on a particular winner of the boys’ footrace but he is also the embodiment of the kalokagathia ethic. His sensually sculpted body emits a genuine sense of presence and his gaze into the distance seems unreachable, as if he is there and not there at the same time, simultaneously present and absent. The tension between the touchable body and this unattainable gaze draws the viewer in. His *being in time* and *being outside of time* creates a tension that leads to empathy. The adolescent boy’s immediate visible form ultimately warrants re-visiting since it embodies vulnerability and strength



at the same time. Philosopher Georg Wilhelm Friedrich Hegel and art historians Edgar Wind, Erwin Panofsky and Gisela Richter all understand the high quality of ancient Greek art as a visual peak that demonstrates the synergy between *The Idea* and the physically visible present form. The kouros type was understood as the embodiment of this, with gods having human traits in Greek culture, “the artists’ subject matter was the way in which human existence could come to be imbued with divine spirit, or The Idea.”<sup>19</sup> Spivey specifically seeks to re-contextualise the kouros within their societal usage and explains the divineness of the sculpture as “In ancient Greek usage, to declare a sculpture ‘godly’ (*entheos*) was not simply an aesthetic response, but an article of faith ... the viewers of divine or heroized forms believed that their sculptors had done more than provide souvenirs of greatness. A spirit, an animated power, had been caught in the stone, clay or bronze ... They were accessible; they communicated and what they communicated was mostly encouragement and consolation to the viewers.”<sup>20</sup>

### 2.2.1 Gaze pinned down.



Fig. 53 Bernhard Bleeker *Spear carrier (Der Speerträger)* (1940), at Lietzensee Park, Berlin. Image from <https://tinyurl.com/zt4az44>.



Fig. 54 Siegfried Charoux *Youth* (1948), Tate Gallery, London. Image from <https://tinyurl.com/zvhxddr>.



Fig. 55 Bernard E. Spence *Highland Mary* (post 1852), Walker Art Gallery, Liverpool. Image from <https://tinyurl.com/zlklxep>.

This aloofness is understood as a state of youth itself. Appropriations of the afore-mentioned ancient sculpture remain infused with a sense of aloofness. This detachment is on a purely formal level recognisable in the downward gaze of the male and female youth in Bernhard Bleeker’s *Der Speerträger* (1940, Fig. 53), Harold, J. Youngman’s *Ishmael* (1933, Fig. 59), Bernard Spence’s *Highland Mary* (1852, Fig. 55), John Davies’ *Young Man* (1969-71, Fig. 57), George Minne’s

*Fountain of kneeling youth* (1905, Fig. 61), Siegfried Charoux's *Youth* (1936, Fig. 54), Ron Mueck's *Ghost* (1998, Fig. 58) and Betty Rea's *Kore* (1963, Fig. 56). These



Fig. 61 George Minne *Fountain of kneeling Youth* (1905), Folkwang Museum Essen, Germany. Image from <https://tinyurl.com/hnsabl9>.

works are connected by a gaze fixed towards the floor at a point approximately 50-100cm from the sculpture's base, as opposed to some distant vanishing point. The majority of these contraposto figures have straight shoulders, flat and muscular chests, small genitals (male) and many of the male figures have attributes such as a spear, ball or stick.

*Der Speerträger* (1940, Fig. 53), *Ishmael* (1933, Fig. 59) and *Youth* (1936, Fig. 54) are specifically modelled in bronze, wood and terracotta respectively as imitations of *Youth (Kritios or Kritian Boy)* (c480BC, Fig. 52). The adolescent boys are rendered not in gigantic rhetorical distortions but with tender empathy. Slightly elongated in their lank and lean bodies, they appear fragile, vulnerable, shy and a little uncertain of the strength of their own bodies. *Youth* (1936, Fig. 54) draws inspiration directly from Greek sculpture. The terracotta figure holds in one slightly outstretched arm a small ball. We see a dreamy, inward-looking boy with a contemplative posture that visualises adolescence as a period of tenderness. The five identical figures around the basin of a circular fountain in *Fountain of kneeling youth* (1905, Fig. 61) show a more severe form of inwardness. The boney boy, repeated five times with his hands clutching his own shoulders and a downward gaze, is a figure that expresses anxiety and resignation. If the fountain is filled with water, the single but repeated statue of the kneeling boy would gaze into his own reflection leading to further multiplication of self-absorbed resignation. *Highland Mary* (1852, Fig. 55) clutches the bible in her right hand. Her head and shoulders are covered with a large shawl held in position with her other hand. The work references ancient sculpture of maidens at the cusp of entering full adult life and her downward gaze is a sign of modesty and purity of the unmarried young adult.

The larger than life-size *Ghost* (1998, Fig. 58) presses her back against the wall with hands tucked in behind and elongated legs that add to the unease. Her downward gaze avoids eye contact with the viewer and her whole demeanour encapsulates



Fig. 56 Betty Rea *Kore* (1963), Old Harlow, London. Image from <https://tinyurl.com/jfh4jve>.



Fig. 57 John Davies *Young Man* (1969-71). c/o Malborough Fine Art, London. Image from <https://tinyurl.com/z54l4nc>.

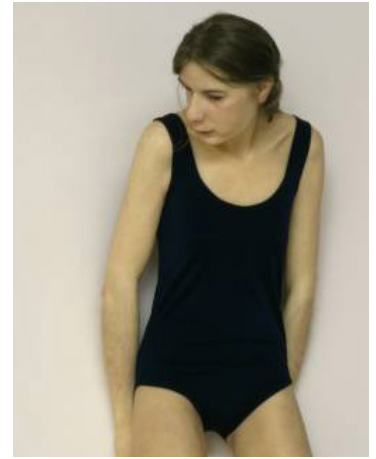

Fig. 58 Ron Mueck *Ghost* (1998), © Ron Mueck, Tate Gallery. Image from <https://tinyurl.com/gr4qj7k>.



Fig. 59 Harold, J. Youngman *Ishmael* (1933). Image from *Modern British sculpture, 1939*, Royal Society of British Sculptors. Published 1939



Fig. 60 *The Spinario* (Roman copy of a Hellenistic work of the 300BC), British Museum, London. Image from <https://tinyurl.com/jjrlp44>.

the bodily discomfort associated with adolescence and is exposed and highlighted by the swimming costume. The heightened scale of the sculpture echoes the manners in which the teenager feels anxious at being the subject of others' attention and curator Susanna Greeves suggests that "*Ghost* is the embodiment of teenage self-consciousness, the projection of a stage at which our bodies become suddenly large and strange and acutely embarrassing to us."<sup>21</sup> *Young Man* (1969-71, Fig. 57) is also uncomfortably positioned near the wall with his downward gaze and slightly awkwardly fitted suit and *Kore* (1963, Fig. 56) is only slightly less uneasy in her own body. Also near a wall, her gaze is slightly lifted, but again she avoids eye contact with us. Her arms are held close to her body and her posture projects a reserved vacantness and unease. Less rosy and dimpled than Rea's earlier work, *Kore* (1963, Fig. 56) is "leaner, tougher, more loaded and concentrated."<sup>22</sup> Free from rhetorical devices, this work is a sign of the artist's humanist idealism and her hopes for a better life, one that celebrates domestic themes such as children playing or resting and adolescent girls being in time.

## 2.2.2. Eyes focused on an object and the interaction with that object.

*The Spinario (Thorn-Puller)* (Roman copy of 300BC, Fig, 60) visualises self-absorption in a different way. Here we see the youth occupied with himself in an activity that keeps the rest of the world outside. The sculpture shows a boy of about twelve bending to extract a thorn from his left foot and, though the illustration shows a Roman copy of a Hellenistic work of the third century BC, the “natural pose has all the suppleness of Hellenistic art”<sup>23</sup> and was the most copied antique visible in Rome. The tension within the figure is particular evident in his back that



Clockwise from top left: Fig. 62 Vrutos Georgios *The Boy with the Crab* (1891). Image from <https://tinyurl.com/z63do6h> . Fig. 63 Edward Onslow Ford *Peace* (1887-1889), Walker Art Gallery, Liverpool. Image from <https://tinyurl.com/gp8dnny>. Fig. 64 George Fullard *The skipping girl*, (1955). Image from <https://tinyurl.com/guev8mu>. Fig. 65 Gyzis Nikolaos *Girl Sewing* (1898), Nikolaos Ioannis Iliopoulos Bequest. Photograph by Brigitte Jurack.

is bent to dislodge the thorn. The intensity of this effort is supported by the overall composition whereby the torso and head together with the bent leg form a closed double loop of the figure of eight. This in turn creates a sense of autonomy, suggesting that *The Spinario (Thorn-Puller)* (Roman copy of 300BC, Fig, 60) is in perpetuity in his own world into which the viewer cannot enter. He is looking at his own body that has been ruptured by nature and this now requires his full and unadulterated attention.

*The Spinario (Thorn-Puller)* (Roman copy of 300BC, Fig, 60) as an image demonstrates an absorption in the self that is prompted by the outside world.

Vrutos Georgios' *The Boy with the Crab* (1891, Fig. 62) and Edward Onslow Ford's *Peace* (1887-89, Fig. 63) are two examples that revisit this motif in relation to nature, whilst Gyzis Nikolaos' *Girl sewing* (1898, Fig. 65) and George Fullard's *The skipping girl* (1955, Fig. 64) exchange nature with that of the gendered culture of sewing and skipping. Different in scale, modelled surfaces and material, their compositions echo the figure of eight as if 'freezing' the sense of concentrated detachment of the sculpted youth forever. *Girl sewing* (1898, Fig. 65) and *The skipping girl* (1955, Fig. 64) are both small statuettes of adolescent girls absorbed in controlled and caring activities. The posture of their bodies and the attributes of thread, fabric





Fig. 66 Siegfried Charoux *Seated boy: The dreamer* (1936), Collection H. Kreitman Esq, London. Image from <https://tinyurl.com/zl3m56c>.



Fig. 67 Paul Bronisch *Schauender Junge* (1954), Kassel, Germany. Photograph by Brigitte Jurack.

and string create a sense of absorption into an action representing a world that is discreet, private and detached. Reference to games and play resurface in Fullard's work to emphasise the therapeutic or repetitive aspect of play.

*The skipping girl* (1955, Fig. 64), held within the figure of eight composition

is the physical manifestation of the intangible and incalculable and reveals "time through a sense of moments not consecutive but simultaneous and integrated into a single totality of the instant."<sup>24</sup> The easy magic of the girl is captured as an element of life.

The final two images from Pinboard 2 demonstrate a different but related withdrawal. Paul Bronisch and Siegfried Charoux create the seated adolescent boys *Seated boy: The dreamer (Träumer)* (1936, Fig. 66) and *Schauender Junge* (1954, Fig. 67) respectively. *Seated boy: The dreamer (Träumer)* (1936, Fig. 66) has his legs tightly drawn in and is leaning back a little with his very strong hands half resting on and half caressing one of his calves and knee. He is muscular with his head slightly bent and his eyes are closed. He is listening, inward-looking and dreamy. The slightly larger than life-size *Schauender Junge* (1954, Fig. 67) sits beside a staircase in the pedestrianized shopping street of Kassel. With one leg drawn in and the other supported by his left hand, he presents his lean and flat torso while appearing relaxed and at ease with the world. His facial features are even and he gazes into space without looking, a 'listening' look that has not yet focused on a particular goal.

### 2.3 Pinboard 3 (Fig. 68)

#### Motif 3: Youth in a state of physical vulnerability.



Fig. 68 PINBOARD 3: *Photographs on wall of Alternator Studio, 2012- (restaged 2017)*. Image by Brigitte Jurack.

Being physically vulnerable is the thread running through Pinboard 3's images. I use the term vulnerability here in regard to the not yet fully matured body and identity that has already surfaced on Pinboards 1 and 2. The focus now lies on the physical vulnerability of youth during sleep and when faced with both physical and mental threat. In this section, youth is shown as a state of physical fragility and vulnerability. The ultimate vulnerability of the living human being lies in death, when the living body turns into a dead object, having come to extreme harm. Pinboards 1 and 2 captured sculpture of youth that conveyed images of strength, virility, joy, hesitation and inwardness. As such, they stand witness to the magic of dead material coming to life. Pinboard 3 emphasises shifts towards dead material visualising death itself and the constant proximity of death and suffering. These statues and statuettes serve a different function to the works discussed earlier. Depending on their historical and societal context, they call for responses such as grief, shock, anger, piety or political engagement.

### 2.3.1 Death and sleep.



Fig. 69 *Statuette of a Dead Youth* (480-460BC), J. Paul Getty Museum, Los Angeles, USA. Image from <https://tinyurl.com/jzqjg5g>.



Fig. 70 *Kline Monument with a Reclining Girl*, Roman (140-120BC), J. Paul Getty Museum, Los Angeles, USA. Image from <https://tinyurl.com/zhasfn8>.

*Statuette of a Dead Youth* (480-460 BC, Fig. 69) shows the release of death with the male youth lying on his back and lifeless limbs spread. His head is tipped back and his general posture, together with a mark on his shoulder, indicates that this scene may have once included a supportive figure or depiction of a rocky landscape. Unlike the many funerary depictions of children and youth during Antiquity for which the *Kline Monument with a Reclining Girl* (140-120BC, Fig. 70) is an excellent Roman example, *Statuette of a Dead Youth* (480-

460 BC, Fig. 69) shows the moment in which life is replaced by death almost in the action of death itself, as if the liquid bronze has just stiffened. *Kline Monument with a Reclining Girl* (140-120BC, Fig. 70) has a Latin hexameter (inscription) that translates as “here reposes the most beautiful girl, what a pity in such a young age”<sup>25</sup> and the image is identifiable as a funerary sculpture. Art historian Hans Belting and anthropologist Michael Taussig both note that death, marking the end of a person, his/her status in clan, family, society and his/her ‘internal images’, in short the images as experiences of lived life, cause tumultuous ruptures within communities. Death and the subsequent invisibility of this member of the community provides the impetus for the creation of the first images that *represent* the status of the deceased and thus bring him/her back to life.

The funerary monuments of children and young people mark their untimely death and re-instate their visibility in a life-like manner. In *Kline Monument with a Reclining Girl* (140-120BC, Fig. 70), the dead girl is depicted gazing at her pet



dog and holding her toys. Behind her head, Amor (*Eros*) is shown, describing *Todesschlaf* (the sleep of death). Looking down on children and women, Amor symbolises the beauty and grace of the deceased and, in the shape of an eternal god, refers vaguely to an afterlife, symbolically reaching beyond the message of the hexameter. This monument replaces the now lifeless body with an image that is intrinsically bound to an artificial body, namely the marble carving of the figure and its attributes. Belting terms this *the medium*. It is the image of the beautiful but dead girl that needs embodiment in order to acquire visibility. The hexameter, Amor and the scene itself together make up the virtual body of the image, making the physical *absence* visible by transforming it into iconic *presence*. The visible kinship to life and the aliveness of the dead depicted is perhaps what shocks most in *Statuette of a Dead Youth* (480-460 BC, Fig. 69) and *Kline Monument with a Reclining Girl* (140-120BC, Fig. 70).

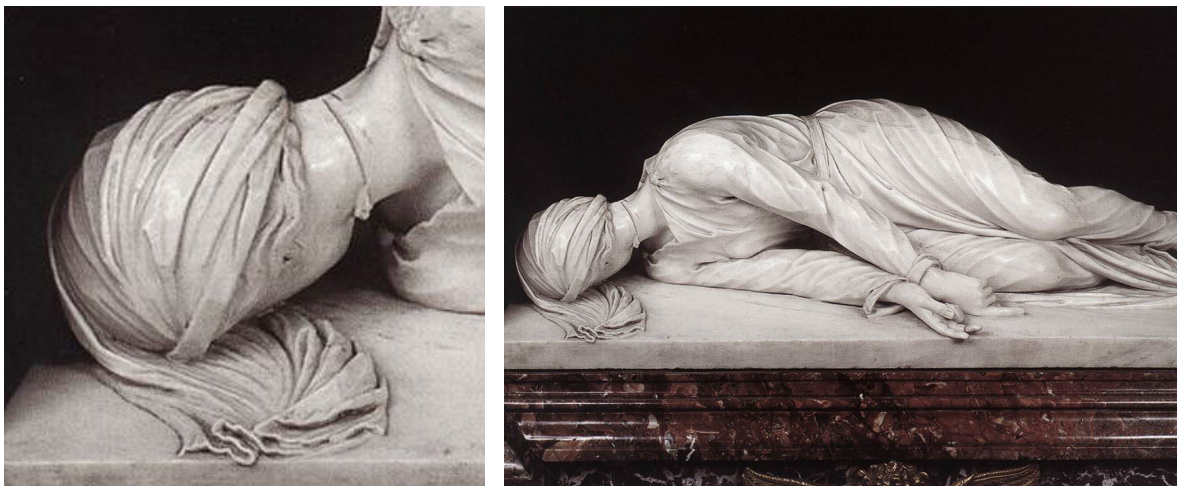

Fig. 71 Stefano Maderno *The martyrdom of Saint Cecilia* (1600), Church of Santa Cecilia in Trastevere, Rome, Italy. Image from <https://tinyurl.com/jdfly3f>.

This aliveness is also present in Stefano Maderno's *The martyrdom of St. Cecilia* (1600, Fig. 71) that is presented alongside the artist's testimony that St. Cecilia is modelled 'from life' after the sculptor claims to have seen the exhumed, intact and uncorrupted body of her before her re-burial. "The sculptor presents her as she was found, her severed head turned away from the spectator, her right hand pointing towards her feet."<sup>26</sup> Though Cecilia's age is not known, her delicate body seems to be that of a young adult or late adolescent female, with face downward and knees drawn together, only her naked feet and hands are visible from underneath the long simple tunic. Her head is covered in a cloth and reveals a delicate neck that displays a cut. "Stefano aims to directly engage the feeling of the viewer with this





Fig. 72 Mark Manders *Isolated bathroom* (2003), Sammlung Goetz, Munich. Image from <https://tinyurl.com/jyh29y6>.

work of art, the body still looks warm while a mark on the neck indicates the axe blow that ended her young life.”<sup>27</sup>

There is a kinship between *Kline Monument with a Reclining Girl* (140-120BC, Fig. 70), *The martyrdom of St. Cecilia* (1600, Fig. 71) and the three lying figures of Mark Manders’ *Isolated bathroom* (2003, Fig. 72). Manders’ figures are covered in polythene and adjacent to a bath that has a wooden tap extended by a ball pen on a string from which water dribbles. He replaces the tunic enveloping the Ancient and Renaissance sculpture with polythene sheets that, albeit nearly see-through, provide an image of delicateness and protection. The figures are cast in bronze and mimic the colour of wet clay and are protected in a way sculptors prevent damp clay from drying out before completion. The figures are also nearly identical. “Two of them are ten percent smaller than the third. The differences appear to have come about inadvertently while trying to make an identical copy of one figure. This cloning is an attempt to show the figure at three adjacent moments in time.”<sup>28</sup> Based on hairstyle and untarnished smoothness, we can perceive the figures as young. They have their heads wedged up and forward. They have no arms and appear not to be finished. This time they are not overlooked by Eros, but supported by blocks of unused clay. The figures are arrested in a state of flux and they repose in a total state of incompleteness, appearing strong and simultaneously susceptible to physical change. The bath is similar in shape and size to an Etruscan sarcophagus and has a wooden tap with water dripping from the pen. The association of water and sarcophagus heightens the sense of the physical vulnerability of the figures, which could either dissolve in water or crumble into dust. The allegorical figure of Amor has been replaced by bathtub and water and their allegorical reading as life nourishing and eroding force. *Isolated bathroom* (2003, Fig. 72) makes the physical *absence* present by transforming it into an iconic *presence* and invites the viewer to observe the fragility of the body as an actuality ‘unfolding’ in front of him/her. “They look very fragile and changeable, but they seem to feel secure in their surroundings. Another reason they have no arms is that I wanted them to look unfinished, and I realised they would then look more alive. The figures have been sprayed to appear wet and



Fig. 73 David d'Angers *Le Jeune Barra (The Young Barra)* (1843), Musee des Beaux Arts, Angers, France, Copyright: © Courtauld Institute of Art. Image from <https://tinyurl.com/zlr9p4f>.



Fig. 74 Paul Thek *The Tomb-Death of a Hippie* (1967), Kourosh Larizadeh Collection, Los Angeles. Image from <https://tinyurl.com/zakn9dq>.



Fig. 75 Pia Stadtbäumer's *Schlafendes Kind mit Pferdchen* (2000), Heidelberg. Image from <https://tinyurl.com/zfmqvmh>.

covered with thin plastic. In a strange way, the plastic also makes them more alive, but at the same time it conveys the uncanny feeling of not being able to breathe, of murder."<sup>29</sup>

The untimely death of a specific individual youth and its significance for a larger cause, such as the French Revolution, is marked by David d'Angers' *Le Jeune Barra (The Young Barra)* (1843, Fig. 73). Too young to enlist in the war, twelve-year-old Barra joins as a drummer and is killed even before the battle begins. It is said he dies pressing the rosette of the tricolour onto his heart. Lying on his side with his legs drawn in, the right hand clutches the rosette. Sculpted in the nude, the smooth young body looks unharmed and his longish hair flops in full waves around his delicate facial features. The left foot remains hidden in a stocking and his groin is covered by the belt that holds the drum. His right hand is outstretched and grasps the drumsticks. The tragedy that strikes this specific youth is not in vain, since the statue immortalises the young Barra. Like the *Statuette of a Dead Youth* (480-460 BC, Fig. 69), this statue provides the viewer with an image that seeks to freeze the moment of death with the early adolescent boy holding his drumsticks and his eyes still half open. These statues and statuettes capture death as occurring in a manner more akin to sleep or rest, rather than death in its physical form

as we know it from bog bodies, Renaissance boxwood carvings of *momento mori* or Paul Thek's *The Tomb-Death of a Hippie* (1967, Fig. 74). Perhaps sleep-likeness is considered more appropriate for children and adolescents that die prematurely. Pia Stadtbäumer's *Schlafendes Kind mit Pferdchen* (2000, Fig. 75) shows a pre-adolescent child cast in an off-white composite material lying on its side with legs slightly drawn in and head resting on one hand. Curled up into a half a ball, the figure, just like *The Spinario (Thorn-Puller)* (Roman copy of 300BC, Fig, 60), emits a sense of being contained and safe in its own world. Isolated in the centre of the roundabout-like plinth, a white horse appears to trot around the child, enhancing the notion of the otherworldliness of dream, the temporary exclusion of the world which sleep provides.

### 2.3.2 Violence.



Fig. 76 Ron Mueck *Youth* (2009), Hauser & Wirth. Image from <https://tinyurl.com/ho7wsvc>.

The proximity to death as violent rapture for early male adolescents is expressed in Ron Mueck's *Youth* (2009, Fig. 76). Displayed on a high plinth that raises the small figure to the eyelevel of the spectator and dressed in baggy jeans and white T-shirt, the black adolescent boy lifts up his blood stained T-shirt on the right-hand side of his chest, pointing and perhaps touching with his left hand a stab wound. His gaze is directed towards the violent injury. He is standing upright and we, the viewer, realise that what we see is a near miss and the solitude within which the adolescent boy 'has to deal with it.' The "tiny size of the figure signifies the fragility of youth along with our collective responsibility to care for and protect that fragility .... and it mitigates any sense of menace that might have been associated with such a figure, which is the conventional attitude to young men, especially young Black men."<sup>30</sup> Furthermore, the vulnerability is shown here as a "function of their youth and inexperience, but also of living in a society that conventionally positions them (young black men) as 'problematic' and 'potentially dangerous'".<sup>31</sup> *The martyrdom of St. Cecilia* (1600, Fig. 71) and *Le Jeune Barra (The Young Barra)* (1843, Fig. 73) commemorate the violent death of unique young individuals who die for the causes of Christianity and Revolution respectively. *Youth*



(2009, Fig. 76), in the context of contemporary London, is also a political statue that makes visible the increased levels of knife crime, especially amongst young black men. In his isolated vulnerability, *Youth* (2009, Fig. 76) is comparable to the martyr status of Cecilia and Barra, but he remains nameless and as such is perhaps more representative of the everydayness and randomness of knife crime and prejudice. But what has he been sacrificed for, other than a society that creates such dangerous urban environments? Far from being sacrificed for a good cause, this image of a vulnerable black adolescent boy becomes a signifier of societal problems, as “socially and politically, the sculpture argues our individual responsibility for the protection of the young and for the creation of a social environment within which our interconnectedness is recognized and respected.”<sup>32</sup>

### 2.3.3 Physical Exploitation.

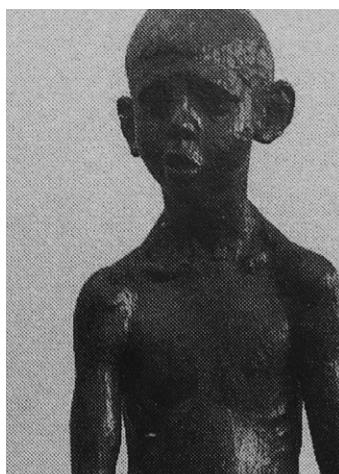

Fig. 77 Christoph Voll *Nackter Junge (Joseph)* (c1925/6), Von der Heydt-Museum, Wuppertal, Germany. Image from Von der Heydt-Museum, Wuppertal.



Fig. 78 Maurizio Cattelan *Untitled* (2004), The Fondazione Nicola Trussardi. Image from <https://tinyurl.com/junv493>.



Fig. 79 Maurizio Cattelan *Amen* (2012-13), Centre for Contemporary Art Ujazdowski Castle, Warsaw, Courtesy of Maurizio Cattelan's Archive. Image from <https://tinyurl.com/grm7vxg>.

Vulnerability as physical exploitation of the adolescent body is visualised in Christoph Voll's *Nackter Junge (Joseph)* (c1925/6, Fig. 77), Maurizio Cattelan's *Amen* (2012-3, Fig. 79) and *Untitled* (2004, Fig. 78) and Chapman Brothers' *Zygotic Acceleration, Biogenetic, De-Sublimated Libidinal Model (Enlarged x 1000)* (1995, Fig. 80).

*Nackter Junge (Joseph)* (c1925/6, Fig. 80) is a woodcarving of a skinny but muscular boy with large hollow eyes and very short hair. He appears awkward in front of the viewer. This early adolescent boy seems malnourished and his body



distorted by a combination of manual labour and lack of food, as evidenced by his large hands and eyes. His sloping shoulders add to the sense of despair. Without any attributes, this figure itself becomes a carrier of a concrete social concern; *Nackter Junge (Joseph)* (c1925/6, Fig. 77) shows what children were robbed of and cheated out of during a childhood in the 1920s.

*Amen* (2012-3, Fig. 79) and *Untitled* (2004, Fig. 78) are statues of fully clothed late childhood/early adolescent boys that hang with their eyes wide open from nooses strung up in trees and flagpoles. Their appearance is lifelike, in as much as they appear to be wearing real jeans and shirts and have genuine hair. Cast in polyurethane (resin), the facial features and hands are similar to those of Mueck and Hanson, with the uncanny resemblance of mannequins and wax figures. The boys are suspended high above the viewers' heads. They have become victims of a world gone mad. Dangling from trees in Italy and flagpoles in Poland, the environments within which they are exhibited contribute to the shock value of the image. It is as if a nightmare has been acted out and fiction such as Jeffrey Eugenides' *Virgin suicides* (1993) has been translated into sculptural reality.<sup>33</sup> Again, the artist focuses on pre-adolescent boys as if to highlight the problem of violence in relation to male identity formation.

*Zygotic Acceleration ...* (1995, Fig. 80) hastens the idea of a world gone mad. In this conglomerate of multiple life-size mannequins that represent bodies of early adolescents, exploitation is shown as a form of over-sexualisation and designer consumerism. The figures are distorted into a nightmare



Fig. 80 Jake and Dinos Chapman  
*Zygotic Acceleration, Biogenetic,  
De-Sublimated Libidinal Model* (1995),  
Saatchi Gallery. Image from [https://  
tinyurl.com/h7flqq7](https://tinyurl.com/h7flqq7).

come true. This group of molded-together mannequins appears cloned with caricatured orifices and genitals growing from their faces whilst their feet are stuck in designer brand trainers. Shocking in many respects, the sculpture is a discomfiting representation of the sexualisation of children. *Zygotic Acceleration ...* (1995, Fig. 80) presents late childhood and early adolescence within a deformed reality. Alluding to science fiction and medical research, the work is particularly disturbing since it affronts what we wish to preserve as natural and protect.



Fig. 82 Ernest Eugene Hiolle *Narcisse* (1868), Palais Beaux-Arts, Lille, France. Image from <https://tinyurl.com/zkqoqt8>.

Ernest Eugene Hiolle's *Narcisse* (1868, Fig. 82), George Segal's *Girl Looking into Mirror* (1970, Fig. 81) and Manders' *Unfired Clay Figure* (2005-6, Fig. 83) show vulnerability of youth as a silent dialogue with the externalised self. *Narcisse* (1868, Fig. 82) appropriates the form and mythology of Antiquity. Narcissus is the extremely beautiful late adolescent who becomes obsessed with himself and is condemned by Echo to fall in love with his own reflection in the water. The statue shows the moment where the beautifully rendered youth looks into the water, his adolescent body turning and twisting as if corkscrewing itself into the act of looking with the fingers of his right hand touching his reflected image. This illustrates the torment of the soul and the abandonment of the body to his impossible love. The fate that follows, namely his death, is announced through the use of narcissus flower heads in his loose hair. Hiolle's rendering of the adolescent boy in the nude follows the double circles of the figure of eight, as if to suggest that the figure remains in perpetuity in the moment of touching or succumbing to death by self-love and an indulgence with self that omits others.



Fig. 81 George Segal *Girl Looking into Mirror* (1970), Collection Mr and Mrs Frederick R. Weismann, Beverly Hills.

*Girl Looking into Mirror* (1970, Fig. 81) freezes the everyday scene of watching oneself in the mirror that is also a form of self-observation and scrutiny. We see the ghost of the girl (the plaster shell) with her human presence stilled and muffled inside the plaster shell. The potential danger of self-love visualised in the vis-à-vis of Narcissus with his own image has been extended to include the audience in *Girl Looking into Mirror* (1970, Fig. 81) where the ghost of the girl,



Fig. 83 Mark Mander's *Unfired Clay Figure* (2005-6), Dakis Joannou Collection, Athens. Image from <https://tinyurl.com/zyuo4ph>.

her image and the spectators and his/her image are entrapped. The scene illustrates the vulnerability of the figure in relation to her own past (the act of making the mold), present (the act of looking) and future (the act of being looked at). *Narcisse* (1868, Fig. 82) and *Girl Looking into Mirror* (1970, Fig. 81) embody vulnerability of youth as a weakness that is caused by the recognition of the self in the reflection, not only the literal reflection of mirror and water, but the reflective surfaces as metaphor for externalised dialogue with self, with the potentially dire consequences of death or self-loathing under the scrutiny of oneself and of the

others. The hollow girl looking in the mirror is whole and complete; her double is her image in the actual mirror.

*Unfired Clay Figure* (2005-6, Fig. 83) makes three-dimensional reality of the split of one figure into two, whereby mirroring surfaces are replaced by worn timber cobbled together like a driftwood raft. Vertically split, the cut through the figure is just off-centre and the sections line up imperfectly as the smaller half sits a few centimeters above the other. Suspended slightly over three school chairs, the gender of the *Unfired Clay Figure* (2005-6, Fig. 83) remains undetermined. The facial features, modelled hair and limbs appear to belong to youth more than childhood or old age. The floorplan of a house created from remnants of the artist's studio lies below the figure, which appears strong in its vulnerable state, despite being violently split. Though we see only one figure, the slight shift in the alignment of the two parts across the wooden board and the fact that the figure hovers above the floorplan suggests the reading of the figure as double or split self.

In summary, this chapter has revealed three key motifs in the sculptural representation of youth.

The first motif of rehearsing and displaying fitness demonstrates the transition from child to adolescence and onto a readiness to enter adult life and can be traced back to Ancient Greece. Whilst artefacts from that period epitomise eudemonia (happiness of body and mind) as a result of stringent education, the larger than

life and distorted rendering of the athletic during Fascism celebrates an image of youth as superhumans. These are “set up to outperform their ancient ancestors as proclaimed on the inscription over the front entrance of the stadium: ‘Italians, let the glories of the past be superseded by the glories of the future.’”<sup>34</sup> The flipside of the victory and physical strength displayed in the statues of Pinboard 1 is the uncertainty of dialectic forces such as the push and pull of sexual self-awareness, the independence gained through assimilation and the self as it is perceived by others in the context of the public performance of ‘near readiness.’

The second motif of self-absorption visualises aloofness and awkwardness. This motif was identified as a feature of the kouros and combines in one single figure a universal and yet attainable quality. For Spivey, the kouroi are “like a wound-up spring ready for action.”<sup>35</sup> Youth (Kritios or Kritian Boy) (c480BC, Fig. 52) is specific and generic at the same time and together with The Spinario (Thorn-Puller) (Roman copy of 300BC, Fig, 60) have been the most influential Ancient sculpture of young people during late childhood and adolescence. These statues render these developmental phases as states of inwardness at once restrained and assertive. Rea, Charoux, Bronisch, Youngman and Fullard focus on the dreamy and precarious state of self-absorption that is associated with youth while adding humanism to the motif. Mueck and Davis shift their attention towards a withdrawnness that is caused by the awareness of the gaze of the other in defining the growing self. For Ford and Spencer, withdrawal is depicted as a sign of innocence that is challenged by Minne’s fountain work that mirrors and magnifies a sense of despair and resignation that may occur during adolescence.

The third motif of physical vulnerability and fragility is problematic in terms of defining harm in relation to the ultimate physical vulnerability, namely death. Harm and death have different cultural significance in relation to age, thus making the death of and harm to children and young people particularly traumatic experiences. The works on Pinboard 3 illustrate that far from being portrayed as strong and invincible guarantors of the future, the strong and healthy body of male and female youth can wither away through violent trauma including sudden death and injury, exploitation and suicide. The scandal of premature death and destruction has been visualised in three different ways; statues as stand-ins for the deceased adolescent and warranting some form of afterlife for family, religious believers and the nation



(Maderno, d'Angers); statues as *momento mori* visualising vulnerability arrested as a moment of strength (Hollie, Manders, Segal) and finally statues as social critique, visualising the sexual, commercial and physical exploitation of the adolescent body (Chapmans, Voll, Cattelan).

## Endnotes

1 Johnson, C., *About the Mnemosyne Atlas*, date unknown, online, available at: <https://tinyurl.com/k7wnone> [accessed 13.2.2017].

2 *ibid*

3 Levi, G., ed. *A History of Young People in the West, Part I: Ancient and Medieval Rites of Passage*, 1999, Cambridge Mass. and London.

4 Müller, C., *Kindheit und Jugend in der griechischen Frühzeit*, 1990, Focus, Giessen, Germany.

5 Good, A., *Archaeology of Daily Life, Ephidrismos Group (Piggyback Girls)*, date unknown, online, available at: <https://tinyurl.com/mmtvrdv> [accessed 03.01.2016].

6 *ibid*

7 McRobbie, A., *Feminism and Youth Culture*, 1991, Macmillan, Basingstoke, p201.

8 Schnapp, A., *Young People in the Greek City State*, 1997, in Giovanni, L. and J-C Schmitt, eds, trans. C Naish, Cambridge Mass. and London, Belknap Press of Harvard University Press, p28.

9 Mattusch, C., *The Victorious Youth*, 1997, Getty Museum Studies on Art, Los Angeles, p41.

10 Blunt, A., *Peter Peri*, 1936, *The Spectator*, online, available at: <https://tinyurl.com/kosadgx> [accessed 10.4.2017].

11 *Video Postcard: Charles Ray's School Play*, 2015, Art Institute of Chicago, available at: <https://tinyurl.com/mte8nkr> [accessed 29.03.2016]

12 Michaud, P-A., *Aby Warburg and the Image in Motion*, 2007, Zone Books, New York, p84.

13 Spivey, N., *Understanding Greek Sculpture, Ancient Meanings, Modern Readings*, 1997, Thames & Hudson, London, p101.

14 Richter, G., *The sculpture and sculptors of the Greeks*, revised edition, 1967 (first edition 1929), New Haven and London, Yale University Press, p54.

15 Spivey, p122.

16 Richter, p58.

17 Spivey, p22.

18 *ibid* p36.

- 19 Richter, p58.
- 20 Spivey p228.
- 21 Catalogue entry, Tate, online, available at: [http:// https://tinyurl.com/gr4qj7k](http://https://tinyurl.com/gr4qj7k) [accessed 13.2.2017].
- 2 Rea, B., *1904-1965 Sculpture (Retrospective Exhibition of Sculpture)*, 1965, Zwemmer Gallery, London, p3.
- 23 Bober, P., and R. Rubinstein, *Renaissance artists and Antique Sculpture, a handbook of sources*, 2011, Harvey Miller Publishers, Oxford University Press, p235.
- 24 Fullard, G., *Sculpture and Survival*, 1959, originally published in: *The painter and sculptor*, Vol.2, Nr.2, Summer, no pagination.
- 25 Koch, G. and K. Wight, *Roman Funerary Sculpture: Catalogue of the Collections*, 2006, Getty Publications, Los Angeles, p11.
- 26 Boucher, B., *Italian Baroque Sculpture*, 1998, Thames & Hudson, London, p31.
- 27 *Visual Arts Cork: Stefano Maderno (1576-1636)*, online, available at: <https://tinyurl.com/kkvx3ar> [accessed 13.2.2017].
- 28 Manders, M., *Isolated Bathroom*, 2003, artist's statement, online, available at: <https://tinyurl.com/mtgmvz5>, [accessed 13.2.2017].
- 29 ibid
- 30 Cranny-Francis, A., *Sculpture as deconstruction: the aesthetic practice of Ron Mueck*, 2013, *Visual Communication* 12(1), online, available at: <https://tinyurl.com/l9snec4> [accessed 16.09.2016], p14.
- 31 ibid p16.
- 32 ibid p16.
- 33 Eugenides, J., *The Virgin Suicides*, 1993, Farrar, Straus and Giroux, New York.
- 34 Prettejohn, E., *The Modernity of Ancient Sculpture*, 2012, Tauris, London, p219.
- 35 Spivey, p110.



## **Chapter 3 – Interpretation of gallery works.**

The previous chapter identified three motifs that resurface in the sculptural representation of youth since Ancient Greece. It should be restated that these motifs only revealed themselves to me during and as part of the process of making in the studio, as described in Chapter 1, and the recalling of other artists' sculpture, as discussed in Chapter 2. Having previously considered the motifs in isolation, this chapter shall now take each motif and discuss my own works in relation to them. In doing so, each is further broken down into a series of 'almost opposites', each category containing its own contradiction. For example, the rehearsing of physical fitness shifts into taking risks and vulnerability mutates into victimisation and fragile confusion.

### **3.1 Youth in a state of rehearsing and displaying fitness (readiness).**

*Boy with mouse* (2009, Part 1 Plates 54-58), *Boy with parasol* (2009, Part 1 Plates 59-63) and *Girl with fire* (2011, Part 1 Plates 64,65) are works that represent pre-/adolescent girls and boys in various states of play. They reflect adolescents' rehearsals of fitness in regard to their sexual self-awareness and their ability to determine a place in the world for themselves.



### 3.1.1 Taking care.



Title	<i>Boy with mouse</i> (Part 1 Plates 54-58)
Date	2009
Media	Ceramic, plasteline, wooden stools, wool, rubber
Dimensions	Figure height 140cm (other versions stand on 50cm high stool)
Exhibited	<i>Artschool</i> , 2009, Holden Gallery, MMU, Manchester <i>Fresh</i> , British Ceramic Biennial, 2011 <i>Pink Parachute</i> , Grundy Art Gallery, Blackpool, 2012 <i>Figuring</i> , RBS Gallery, London, 2014

The desire to look alike is woven into Peter Brook's film adaptation of William Golding's *Lord of the flies*.<sup>1</sup> In the film a group of pre- and early-adolescent schoolboys are stranded on a Pacific Island and have to fend for themselves. As one group of boys slips into the dress and 'make up' codes imagined to be indigenous to the island, the other group remain in the robes belonging to their school uniform. For both groups the clothes denote different types of engagement with the new, exotic, adventurous and potentially dangerous situation. The robes signify the boys' desire to apply the rules and authority of the school and the establishment, in order to regain control over the traumatic situation. The loincloths signify the other group's desire to abandon those rules and replace them with imagined more 'natural' rules. Specially designed clothes also feature in Sam Taylor's novel *Republic of Trees*, a republic

in the woods created by five runaway adolescent boys and girls.<sup>2</sup> In the story, the utopian community built around Jean-Jacques Rousseau's *Social Contract*<sup>3</sup> turns into a dystopia with violent consequences. The turning point from utopia to dystopia is marked by the designing and making of new robes and the adoption of increasingly coded language and rules. Both Golding and Taylor's narratives explore the imitation of societal structures and ideologies through the lens of play. Within the fictional reality of both novels, what initially appears as quasi-innocent play that mimics the idea of a life free from repressive rules turns into a fictional reality that becomes increasingly disturbing and murderous.

*Boy with mouse* (Part 1 Plates 54-58) embodies the dress-up and playful rehearsal for adult life. The sculpture acknowledges Golding and Taylor's fictional wilderness settings and, on a formal level, Miroslaw Bałka's *Souvenir of the First Holy Communion* (1985, Fig. 47) and Charles Ray's *School Play* (2014, Fig. 48). The work shows a singular figure in an attentive upright posture with arms and hands partially hidden under a wool robe. Together with his grey and brown face, the outfit is suggestive of camouflage for hunting. This work has been exhibited four times, with the most recent installation at the Royal Society of British Sculptors Gallery in 2014 being the most resolved. Between the first and the most recent installation, the statue has been altered dramatically in as far as the originally white and mostly hidden face, has been replaced by a two-coloured face, vertically split in the middle on the cusp of the nose. The right side of the face is covered in brown and the left in grey plasteline. The cape, originally made of packing felt, has been replaced with blue uniform heavy-duty wool. The figure is raised up on an IKEA stool and around one of the ankles is a rubber band fashioned from a bicycle inner tube. The stool is old and marked by studio use with dirt, colour and cut marks. Facing it is the same stool again, and on the first step sits a life-size ceramic mouse. In its first incarnation *Boy with mouse* (Part 1 Plates 54-58) is standing on the floor. His head only just emerges out of an aperture in the felt cape and two mice are on the floor at his feet. As the viewer looks down on the figure, he appears fragile and timid as if caught in the moment of a dressing-up play. The later raised version turns this impression on its head. Now standing higher than the average viewer, the stiff and frontal figure with his two-coloured face exposed appears more powerful, confident and in control. The heavy wool cape covering his torso is more solid and his ankle band mimics an identity tag. The two-coloured plasteline is applied to the face like

make-up with visible edges near the hairline and ears. The coloured vertical split across the face is disconcerting in as far as it signifies two different purposes for the camouflage. Does the figure belong to a club of boy warriors or young shepherds? Is he rehearsing stewardship or war whilst positioned on his domestic makeshift podium? The mouse provides another clue. The mouse is an essential part of the ecosystem yet becomes a pest in urban man-made settings. A mouse may also be used for bio-chemical experiments to test out the side effects of newly developed cosmetics. Echoing the two-coloured face, the mouse embodies both a positive and negative potentiality. Samuel Johnson's poem uses the metaphor of making an elephant out of a mouse, suggesting the dis/proportionality of reaction in the face of adversity.<sup>4</sup>

*Boy with mouse* (Part 1 Plates 54-58) initially appears as a picture of play yet his attire and attributes leave no doubt that this dressing-up game has military undertones and pastoral associations. The game he seems to play facilitates the learning and assimilation of future roles. He embodies both the shepherd and the hunter, the destroyer and the nurturer. Holding two options in the balance, he is literally positioned one step above the mouse and above the viewer's gaze, suggesting that his future role is out of the viewer's current reach. The rehearsal is held in balance here, yet ultimately it remains unknown whether proportionality will prevail.



Title *Boy with parasol (Part 1 Plates 59-63)*  
 Date 2009  
 Media Ceramic, parasol, wooden cupboard  
 Dimensions Figure height 130cm, standing on 90cm high cupboard  
 Exhibited EKWC, Hertogenbosch, The Netherlands, 2009  
*Fresh*, British Ceramic Biennial, 2011



Fig. 84 Hertogenbosch Cathedral.  
 Image by Brigitte Jurack.

Alongside the side roof gables of the cathedral in Hertogenbosch stand a series of carved figures. One of these is a young looking knight (Fig. 84) holding his shield in front of him. He is not depicted in action, but in an upright, still position with the shield resting as if a protective screen in front of his mostly hidden body. Like a guard, his significance lies in his protective role, symbolically defending the cathedral and its values. *Boy with parasol (Part 1 Plates 59-63)* appropriates this idea of protection but situates it in a completely different context, namely a domestic setting within an art exhibition. He holds a readymade parasol and his surface of an unsettling bubble glaze that smudges and distorts his facial features. The work is first exhibited on pallets and a sculpture trolley and whilst these provide a less fixed base, neither are satisfactory due to production faults within the sculpture



itself. Shrinkage of the clay during the drying period is rushed, leading to proportional distortion of the legs that become too short in the process. Unlike all the other figures discussed in this chapter, *Boy with parasol* (Part 1 Plates 59-63) is not modelled at height nor with distance of vantage point in mind. This leads to misjudgements in regard to the lack of eventual elongations of lower limbs. The cupboard deployed as a plinth provides the right height but there remains a sense that the whole scene is odd or 'not right.' Taking into consideration some of these issues, the distressed surface covering the intricate features of the boy in shorts is reminiscent of some form of corrosive growth, or a growing old before one's time, possibly an allergy or physical reaction to trauma. Pockled with blisters, this surface ageing, unlike that on ancient bronze statues, cannot be cleaned off. If the figure embodies a boy grown old before his time, what is he doing on the top of a domestic cupboard clutching a parasol? Has he quite literally burned in the sun? Has his protective shield failed him? Has the domestic environment failed him? Should he have been protected rather than being a protector? In this work, the ambivalence of meaning is unsettling, alluding to summers spent playing in the garden hiding under parasols for shade. The parasol signifies a yearning for lengthy summer holidays as periods of easy outdoor living. It protects from the sun and reminds us of times when we are freed from school or work. In the hands of a boy who appears to have aged before his time, the parasol signifies opposing possibilities. It remains uncertain whether the boy embodies a childhood from a distant past that has resurfaced through the presence of the parasol or if, alternatively, he is in the midst of his childhood but his protective play shield has failed him and left him scarred with irreparable blemishes.

### 3.1.2 Taking risks.



Title	<i>Girl with fire</i> (Part 1 Plates 64,65)
Date	2011
Media	Ceramic, wooden table, burning paper and ash
Dimensions	Figure height 140cm, standing on 30cm high table
Exhibited	<i>Fresh</i> , British Ceramic Biennial, 2011

In Chapter 2, Hanson's *Cheerleader* (1988 Fig. 37), Degas' *Little dancer aged fourteen* (1880-1, Fig. 35) and Warren's *Girl 13* (2003, Fig. 38) highlighted manners in which dance signifies the growing independence of adolescent girls. *Girl with fire* (Part 1 Plates 64,65) appropriates the notion of the performing adolescent girl whilst simultaneously altering the sport and the attributes. The work is mounted on a small circular wooden coffee table and she meets her viewers at eye level. She stands tall and upright with her leg muscles tense and wears tight gymnastic shorts and cropped sleeveless vest, all modelled in clay. In full frontal view, her head is held high on a stretched neck, her hair falling in pigtails by the sides of her straightened shoulders. Her gaze is pinned ahead into the distance beyond the viewer's gaze. With her upright posture and gaze, she is self-assured and forward, even bordering on flirtatious. The lower arms are bent forward at ninety degrees and her hands are held out with palms facing up. Inside each palm lies a small burning paper ball of real fire or burnt ash. During the exhibition display, highly combustible paper is

placed on the ceramic palms and set alight. After a few seconds of flames flaring, the burnt paper collapses into a small amount of ash that is left on the open palms. The idiom 'playing with fire' refers to the dangers that come with engaging in a risky activity, such as the forbidden love, risky flirtations or dating the 'wrong' person often quoted in pop lyrics. *Girl with fire* (Part 1 Plates 64,65) lures, both literally and metaphorically. The hot flickering in her palms creates a temporary attraction and pull but it is soon gone. What remains is a hue of burnt paper that rapidly disintegrates into dust. In her posture, she appears ready to perform an acrobatic routine. Her body oozes control and self-confidence. This is a trained and fit body, and the upright frontal position enhances a sense of her demanding our respect and adoration.

By contrast, the slightly flimsy thin-legged Formica coffee table she stands on provides a counter that is certainly less stable than the solid plinth of *Little dancer aged fourteen* (1880-1, Fig, 35). The table can barely support the figure and is reminiscent of circus props that bridge height differences and enhance the visibility of a shorter performer. If jumping off or stepping down from the table, the figure would not only be shorter in relation to the standing viewer, it would simultaneously lose the vis-à-vis and with it the possibility of showing off the well-toned and controlled body that make her feel grown up and mature. The use of ready-made furniture and those newly constructed but mimicking furniture from the 1950s-70s, namely an abandoned modernity of offices and schools, is a common feature in many of Manders' installations. Office or domestic chairs and tables hold, prop and raise his figurative elements, imbuing his installations with a provisional feel. Is the work still in progress, vulnerable to the elements and hence likely to change? The coffee table under *Girl with fire* (Part 1 Plates 64,65) provides a temporal context more akin to the makeshift platforms used by gymnasts and acrobats to elevate the performer. A coffee table rather than a professional gymnast platform is used as if to turn the domestic setting into a stage. The work captures a state of being that is *other*, that condenses the moment of awareness of sexuality of the growing and athletic self on the beholder. It signals a state of precarious explosivity, controlled and yet on the edge of the wobbly table, pretending to be equal to the adult viewer and very obviously artificially raised to meet our gaze. Its allegorical turn brings into presence not only the celebrated athletic, beautiful and young body, but also the dangers of timing in regard to sexual readiness for the other.

### 3.2 Youth in a state of inwardness and self-absorption.

*Monument for Damian* (2008, Part 1, Plates 66-72), *Waiting* (2009, Part 1 Plates 25-30) and *Dunno* (2016, Part 1 Plates 73-79) are statues that represent adolescent girls and boys in a state of inwardness and self-absorption. These are visualised as playful invisibility, ostentatious withdrawal and irresolution.

#### 3.2.1. Playful invisibility.



Title	<i>Monument for Damian</i> (Part 1, Plates 66-72)
Date	2008
Media	Plaster, wax, timber, ceramic, scaffold planks, steel trestles
Dimensions	Figure height 150cm, standing on 160cm scaffold boards
Exhibited	<i>Next Up</i> , 2008/09 Bluecoat Gallery, Liverpool <i>Artschool</i> , 2009, Holden Gallery, MMU, Manchester

Childhood and early adolescence are not necessarily free from trauma and responses can vary significantly amongst siblings. In Frank Cottrell Boyce's novel *Millions*, brothers Damian and Anthony Cunningham suffer the loss of their mother and attempt to start a new life with their father in a modern housing estate in Widnes.<sup>5</sup> The boys cope very differently with their loss. Anthony hides his grief behind delinquent behaviour, while the younger Damian withdraws into a cardboard



hermitage he constructs on wasteland near the railway tracks. He builds it from the boxes they use to move with and in his hermitage he becomes obsessed with Saints and starts communicating with them in the hope that his deceased mother will re-appear. He is coping with his loss through a physical and social withdrawal and a simultaneously expanding imaginative and spiritual hallucinatory capacity.

*Monument for Damian* (2008, Part 1, Plates 66-72) is a sculpture of a pre-adolescent boy who is hiding within the world he has constructed for himself. The statue re-visits *The Spinario (Thorn-Puller)* (Roman copy of 300BC, Fig, 60) and *The Boy with the Crab* (1891, Fig. 62) by moving from the pastoral context of these statues to a contemporary suburban setting. The attributes of nature such as thorn and crab are replaced by the attributes of provisional architectural structures, namely cardboard boxes and scaffolding. The work consists of a life-size bright yellow figure of a pre-pubescent boy in Wellington boots. He towers above the head height of the viewer. Standing with his externalised structural support on the high platform constructed from old scaffolding planks and used steel trestles, he holds a large cardboard box over his head and shoulder. Apertures for eyes are indicated on the surface of the box, but do not allow any view from either inside or outside the box. Sixteen multi-coloured ceramic cubes are randomly located on the scaffolding planks and on the floor of the gallery, looking as though they may have fallen out of the upturned box. *Monument for Damian* (2008, Part 1, Plates 66-72) is modelled directly in plaster over a mild steel framework and covered in yellow wax. The figure emits a glow and the overall arrangement of planks, trestles, cardboard box and cubes contributes to the precariousness and temporariness of imaginative play and as such triggers simultaneously responses of joy and sadness. The raised position of the statue, the use of bright yellow, the attributes and gesture make the work a monument that celebrates the power of imaginative play and described as “glorious and celebratory.”<sup>6</sup> With his head stuck in a box, the boy remains unreachable for the viewer. He is truly in his own world, rendering the rest of existence invisible.

### 3.2.2. Ostentatious withdrawal.



- Title            *Waiting (Part 1 Plates 25-30)*
- Date            2009
- Media            Ceramic, polythene, college tables
- Dimensions    Each figure height 160cm, sitting on tables 200x80x70cm
- Exhibited      Holden Gallery, MMU, Manchester, 2010  
*Figuring*, Royal British Society of Sculptors, London, 2014

In Chapter 2 I identified a lack of eye contact or distant gaze as indicators of inwardness and self-absorption amongst adolescent boys and girls. *Waiting* (2009, Part 1 Plates 25-30) is a sculpture of an adolescent girl and her double who refuse to see or engage with the world around. The sculpture revisits *Ecclesia* and *Synagoge* (c1230, Fig. 86) and *Parable of the wise and foolish virgins* (1250, Fig. 85) but places the scene in a contemporary educational environment. In the original parable, the five virgins who are prepared for the bridegroom are rewarded while those who were not remain unrewarded, the moral being *be prepared for Judgement Day*. Exhibited at the Royal British Society of Sculptors' main gallery space in London, the *Waiting* (2009, Part 1 Plates 25-30) girls sit on slightly scruffy large institutional tables with Formica tops, similar to those used by colleges and universities. Both sit upright with outstretched legs and arms pushed back to support the upper torso. They have broad, strong and slightly raised shoulders and their heads are held high

and leaning slightly forward. Both are modelled with deep undercuts in the torso, upper arms and knee area. The clothing is reminiscent of tight trousers and a loose short-sleeved t-shirt. The lower arms and feet are bare. The hair of both figures is tied up in a bun and both have their eyes blindfolded with polythene sheets loosely knotted at the back.

The two together appear strong and determined in their pose, despite their restricted sight; they are in a world of their own, not victims. The play of light and darkness across the rugged surface of the torso and neck area enhance their expression of liveliness and purpose. This stands in sharp contrast to the distance and temporary withdrawnness indicated by the blindfold and the physical distance between viewer and figures. The figures appear held in a state of solipsistic inwardness, refusing to recognise the world outside the perimeter of the table.



Fig. 85 *Ten wise and foolish virgins* (1250), Magdeburg Cathedral. Image from <https://tinyurl.com/hhvy5oo>.

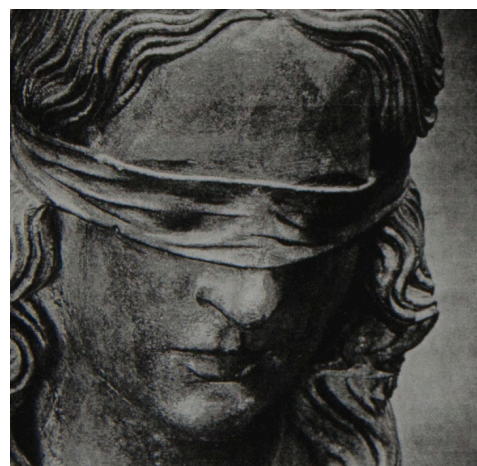

Fig. 86 *Head of the Synagogue* (c.1230) Strasbourg Cathedral. Image by Dr. Stoedtner, reproduced in Panofsky, 1924.

The blindfold as used in *Ecclesia* and *Synagoge* (c1230, Fig. 86) and the hands and veils covering the foolish virgins' faces are used to illustrate ignorance and refusal to recognise the proclaimed truth of the New Testament. Both these works are positioned antithetically to their opposite virtues, the allegorical depiction of *Ecclesia* and the Wise virgins, both carved as seeing with eyes wide open and directed forward and upward. *Waiting* (2009, Part 1 Plates 25-30) quotes this use of the blindfold as a device to illustrate wilful ignorance in regard to the rules prohibiting sitting on school tables and, metaphorically, in regard to being alert and receptive to the world outside. The work has been exhibited in various formations but always with a gap between the girls' feet that keeps the viewer at a distance and hence

keeps the adult world at bay. In this manner, *Waiting* (2009, Part 1 Plates 25-30) adds another dimension to the already discussed statues that demonstrate self-absorption. In this work, the self-absorption is ostentatious, stubborn and forthright. Self-absorption is depicted as active strength claiming its own space.



### 3.2.3. Uncertainty.



Title	<i>Dunno</i> (Part 1 Plates 73-79)
Date	2016
Media	Ceramic, paint, cotton, shellac, wax
Dimensions	Figure height 165cm
Exhibited	<i>Doppelgänger</i> , Arthouse Lewisham, London, 2016

The two adolescent girls in *Waiting* (2009, Part 1 Plates 25-30) are beyond reception and outwith our communicative reach. The two adolescent boys in *Dunno* (2016, Part 1 Plates 73-79) stare out into nowhere in particular. The work is a sculpture of one adolescent boy stuck halfway in a second skin. We see him twice and from herein I shall refer to *Dunno* (2016, Part 1 Plates 73-79) in third person singular. It is not clear whether this second skin is intended to come on or off. The skin is pulled up/down to the waist, mimicking neoprene surf suits and body ‘armour’ used in other sports. *Dunno* (2016, Part 1 Plates 73-79) re-visits *Youth* (*Kritios* or *Kritian Boy*) (c480BC, Fig. 52) and represents vulnerability and strength at the same time. The stillness of the pose in my work could be described as a charged stillness. The shiny waxed and half pulled down wet suit reveals an upright and taut, but not over-muscular, body. The adolescent boy has a strong neck and gazes off into the distance. He does not feel as assured as Hanson’s *Surfer* (1987, Fig. 46) but neither is he as shy or insecure as Youngman’s *Ishmael* (1933, Fig. 59). The neoprene suits

worn for surfing and swimming in cold water suggests a battling of the elements is about to commence. The boy has to prove his agility and endurance in relation to sport rather than hunting and gathering. *Dunno* (2016, Part 1 Plates 73-79) has both the motif of displaying adolescent fitness through sport and, due to the skin being neither on nor off, a moment of still contemplation imagining what lies ahead. In the development of this work, I observe surfers in Ireland and Portugal, particularly noting the moment when they stand and face the ocean, wetsuits half on, before they try to ride the waves like Homeric heroes. As with all sculpture presented here, the titling is crucial. The work suggests the dialectical push and pull between certainty as a future state and uncertainty as the state of the now. This quite literally relates to the idea of nimble-footedness and the ability of becoming the hero by embracing what lies ahead, symbolised by his (or their) second skin.

### 3.3. Youth in a state of physical vulnerability and fragile confusion.

*Boy with knife* (2016, Part 1 Plates 97,98), *If only* (2016, Part 1 Plates 91-96), *Sleeping Beauty* (2015, Part 1 Plates 83-90) and *Boy with jacket* (2002, Part 1 Plates 80-82) are statues that represent adolescent boys and girls in a state of physical vulnerability in regards to death, sleep, exploitation and violence.

#### 3.3.1 Death.



Title	<i>Boy with jacket</i> (Part 1 Plates 80-82)
Date	2002
Media	Jesmonite and PVC bunting
Dimensions	Figure length 190cm
Exhibited	Temporary installation commissioned by <i>Locws International</i> , River Tawe, Swansea

Reports such as the BBC's *Mapping UK's teen murder toll* suggest that the majority of suicides and fatal knife attacks in the UK affect adolescent boys and young male adults. *Boy with jacket* (2002, Part 1 Plates 80-82) is a sculpture of an adolescent boy who is weary, uncertain and on the edge. This edge is literally the end of the bridge column as a remnant of a distant past and not yet fulfilled future. This edge is where his awareness of death lies and his understanding of

self extends to the understanding of the self as mortal and within time. *Boy with jacket* (2002, Part 1 Plates 80-82) re-visits *Narcisse* (1868, Fig. 82) and *Fountain of kneeling youth* (1905, Fig. 61) and locates it in the post-industrial setting of the harbour town of Swansea.

At the time of the exhibition, one side of the river is industrial wasteland on which the Grade II listed wooden and vacant Scandinavian church stands. The church, wasteland and columns are remnants and non-gentrified signifiers of the city's industrial and maritime past. Narcissus is drawn to death by the lure of his own image and the boys in the *Fountain of kneeling youth* (1905, Fig. 61) are caught in anxiety and resignation. The youth in my work also seems racked with doubt and despair. Flanked on one side by boarded-up buildings and brownfield sites and on the other by the anonymity of re-developed land, he perches on a useless structure, the defunct railway bridge columns of the Swansea New Cut Bridge that once carried the Vale of Neath railway from the east side of Swansea into the centre. From the adjacent second bridge column I hang entangled red PVC bunting that plays on the idea of being left behind after the celebrations have long finished. His party is almost over. The River Tawe is 6m below him and his elongated legs, shoulders, upper torso and neck are bent forward as if being pulled by the water below. His gaze is mid-distance. Even from the closest viewing spot of around 40m away, we can observe that the surface of the figure is extremely roughly modelled, with deep undercuts and crevasses that allow for dramatic play of light and shadow. This enhances the overall vitality and uncertainty of the scene when seen from afar. We are additionally helpless, distant and unable to catch his eye. The solitary hooded figure remains on the edge. He may be contemplating jumping to his own death. Suicide lingers in the air. Perched on remnants of the past, the vulnerable *Boy with jacket* (2002, Part 1 Plates 80-82) appears completely uncertain about time, space and his role within it.



### 3.3.2 Sleep.



Title	<i>Sleeping Beauty</i> (Part 1 Plates 83-90)
Date	2015
Media	Ceramic, paint
Dimensions	Figure length 160cm
Exhibited	Vertical Gallery, Benzie Building, MMU, 2015

Sleep is the period in which bodily functions are reduced. It is a temporary shut down and disabling of the primary organ of sight. *Sleeping Beauty* (2015, Part 1 Plates 83-90) is a statue of an adolescent girl who is asleep. Once again, she is shown as two figures, but understood as one work. Her sleeping pose is mirrored in a second almost identical girl. Curled up on one side with legs drawn in and head nestling within the cradle formed by one arm, the scene emits a quiet stillness. This is disturbed by the visible disjointedness of the upper and lower parts of the bodies split in two and the mirroring of the sleeping pose. Having previously hidden the joints between the upper and lower body parts of the ceramic figures, this joint is laid bare and contributes to a reading of the work. *Sleeping Beauty* (2015, Part 1 Plates 83-90) revisits Maderno's *The martyrdom of St. Cecilia* (1600, Fig. 71) and d'Angers' *Le Jeune Barra (The Young Barra)* (1843, Fig. 73). Maderno depicts St. Cecilia with utmost dignity. Her head is turned away from the viewer, revealing the cut to her neck. The young Barra is modelled lying on his side as if sleeping but with no visible

indication as to the cause of his death. *Sleeping Beauty* (2015, Part 1 Plates 83-90) displays rapture, and whilst this initial impression of impalement is counteracted by the facial expressions of a sly smile and the tender nestling of the head, this rapture freezes the moment of vulnerability. She has her eyes closed and head slightly tilted downwards. She shelters from any onlooker who towers above her. The private act of sleeping has been almost entirely stripped of its privacy. She has no plinth or barrier and she appears exposed in shorts and sleeveless top, vulnerable to the viewer, the hardness of the floor and potential threats. It is not clear if one figure is mirroring the other as a three-dimensional reflection or if we witness the passing of time between two different sleep stages. The Conclusion will return to this question. Similar to Manders' work, the painted surface of the figures mimics the colour of wet clay. The illusion of unfired malleable clay rather than petrified ceramic adds to the sense of vulnerability and potentiality of change. The separating gap between the lower and upper body parts, the result of cutting the figures in half, destroys the idyllic associations the viewer might have when seeing the figure of a sleeping girl.

The title of the work leads us to think about Jacob and Wilhelm Grimm's original fairy-tale of *Sleeping Beauty* (*Dornröschen*) in which the fictional pastoral world of woodlands, castle, king, queen and their fifteen-year-old daughter is ruptured by a spell that leads to a hundred-year-old sleep under the protective growth of thorny brambles. Psychologists Bruno Bettelheim<sup>8</sup> and Marie-Louise von Franz sum up the core theme of this fairy tale in their respective psychological interpretations,<sup>9</sup> that being parental awareness of the sexual awakening of their precious daughter. What appears passive, that is, her sleep, is in fact seen as the time the adolescent girl's body is changing, and this change cannot be stopped by the parents. Bettelheim interprets the death-like sleep underneath the thorns as a warning of early sexualisation and as a symbol of narcissistic isolation. For him, the long sleep in the isolated chamber is symptomatic of adolescent behaviour. Within the various versions of the fairy-tale the waking-up of the adolescent girl is performed by a young male prince who cuts away the brambles, kisses and impregnates her even before she wakes up. Thus her virginity is lost through an act of violence. The mirrored and split figure of my *Sleeping Beauty* (2015, Part 1 Plates 83-90) embodies this fragility of the adolescent body alluded to in the fairy-tale and, quite literally cut in half, the sculpted figure is the victim of violence.

### 3.3.3. The passive and defenceless body: victimisation.



Title	<i>If only</i> (Part 1 Plates 91-96)
Date	2015
Media	Ceramic, paint
Dimensions	Figure length 160cm
Exhibited	Vertical Gallery, Benzie Building, MMU, 2015

The risk of sexual exploitation of adolescent girls has been highlighted in the recent Rochdale<sup>10</sup> and Oxford<sup>11</sup> cases. In both places, the desire of adolescent girls to be liked, loved and accepted was ruthlessly and violently exploited by older men. *If only* (Part 1 Plates 91-96) represents a lack of resistance and exposes a defenceless vulnerability of the late-teen female body. It is a body that becomes body for consumption only and not body as carrier of the emerging self. The work is a sculpture of an adolescent girl whose identity is hidden behind a ceramic facial cloth or flannel. She seems to have withdrawn from her body, making it appear detached and one to be looked at. In combination with the title, the statue holds the image of helpless vulnerability of the adolescent girl in danger of losing ownership and control over her own body.

*If only* (Part 1 Plates 91-96) comprises one figure in two states. Both are modelled in tight shorts and sleeveless strap tops. They are lying on the floor, flat

on their slightly arched backs and positioned in opposite directions to each other. The fingers of their half-opened hands nearly touch and their overall look and composition is very similar. Their arms rest parallel to their bodies that are split in half at the height of the diaphragm. Their slightly elongated limbs, pigtailed and hints of clothing inform us that the figures are of adolescent girls. Two-thirds of their faces are covered with what looks like a wet flannel that covers their eyes, forehead and nose, leaving only the lips visible. The viewer looks down on these figures that have become almost faceless and this high vantage point magnifies the frontal exposure of the bodies. What may initially be 'looking at' can slide unhindered into 'staring at' and a 'looking down' can become a devouring. These shifts turn our encounter with *If only* (Part 1 Plates 91-96) into an objectified relationship devoid of personhood or identity. The split of the figure at the diaphragm is significant. There is no doubt here that the bodies are hollow. Split bodies and visible air holes provide clear access as to the materiality of the statues. As in *Sleeping Beauty* (2015, Part 1 Plates 83-90), the sculpture has been cut in half, but this time below the ribcage rather than the waist. The cut is where we may perceive the 'seat of the soul' or the very part of the real body's deepest internal muscles that move, act and contract so readily to outside forces such as fear and danger. The sculpture re-visits the exposed body of *Nackter Junge (Joseph)* (c1925/6, Fig. 77) and the over sexualised mannequins of *Zygotic Acceleration, Biogenetic, De-Sublimated Libidinal Model (Enlarged x 1000)* (1995, Fig. 80). My work adds a new dimension to the motif of exploitation explored by Voll and the Chapman Brothers for while it is equally bleak in its depiction of exploitation, the flannel covering two thirds of the face, the splitting of the figures, the horizontal positioning of them on the ground, the sense of objectification and possible victimisation of the female body is acutely heightened. *If only* (Part 1 Plates 91-96) brings into presence a body that is over exposed and passive, pinned down by the gaze of the viewer. The dignity of the body has been compromised by its separation from identity hidden under the flannel.

The figure appears vulnerable and restrained, an impression that could be altered through a shift in vantage point of the viewer from the all consuming frontal downward view to the kneeling and thus aligning sideward perspective; from consumption towards empathy. Kneeling down, the tenderly opened hands and the very sly smile suggest an additional interpretation of this work. This emphatic alignment allows for the potential for literal and metaphysical touch. We are drawn



to touch and remove the flannel, giving light to the hitherto hidden face and restoring her identity. Metaphorically, touching *If only* (Part 1 Plates 91-96) from the kneeling position is an act of empathy, potentially leading to an acknowledgement of the reality of the embodied trauma without exploiting it further.

### 3.3.4 Violence.



Title            *Boy with knife* (maquette Part 1 Plates 97, 98)  
Date            2017  
Media           Jesmonite  
Dimensions   Figure height 160 cm  
Exhibited     *Foreigners*, Bury Art Museum & Sculpture Centre, 2017

Psychologist Teodora Gliga notes that “Many young people carry knives not with the deliberate intension to harm, but to protect themselves or to gain respect from peers.”<sup>12</sup> *Boy with knife* (Part 1 Plates 97, 98) is a sculpture of an adolescent boy who, like *Boy with jacket* (Part 1 Plates 80-82), is weary and uncertain. The weariness on this occasion is expressed in the carrying of a knife for defensive or offensive purpose and his apathy may stem from over exposure to prolonged fear or the desire to be respected.<sup>13</sup> In both ways, this work re-visits *School Play* (2014, Fig. 48), *Statue of a victorious youth* (300-100BC, Fig. 39) and, more directly, Mueck’s

*Youth* (2009, Fig. 76). My work is of a solitary figure. He is almost completely hidden under layers of baggy clothes, modelled with deep undercuts and crevasses. His head is dwarfed by the big hood with the thick neck part that covers his mouth. In the shelter and shadow of the hood, his facial features remain obscure. The sculpted clothes of *Boy with knife* (Part 1 Plates 97, 98) adopt metaphorical meaning in a manner similar to *Just wait for me* (2012-13). The sleeves of his baggy outfit are extra long and give the impression that his limbs are drawn in. The jacket becomes armour not unlike a tortoise shell into which the soft body parts seek sanctuary and emerge only when safe. These clothes are not only fashion items, but also shelter, oversized and tent-like with giant hoods. They become the protective armour and comforting home at the same time. As *Boy with knife* (Part 1 Plates 97, 98) shelters within his jacket, the tip of a knife nudges out from the inside of the left sleeve. Unlike the sword in *School Play* (2014, Fig. 48) that remains in its protective casing, the tip of this knife is out. We do not witness any violent action, but feel the latent potential of aggression. The knife is a symbol for the difficulties male teenagers may have in decision making, especially under challenging emotional or social conditions with a bias towards choosing immediate rewards such as gaining respect or responding aggressively when sensing hostility. His face is hidden and we do not see whether he has a face of retaliation or fear, but *Boy with knife* (Part 1 Plates 97, 98) presents the image of vulnerability of the adolescent boy. With low self-esteem, he carries a knife because he wants to protect himself or to be respected by peers.

In summary, my sculpture introduces to each motif their own inherent contradictions and opposites. The first motif of rehearsing fitness, primarily around sport, games and dance, is adapted to include taking care or taking risks. *Boy with mouse* (2009, Part 1 Plates 54-58) and *Girl with fire* (2011, Part 1 Plates 64,65) introduce this ambivalence to the notions of play and rehearsal – are these young people really at play and ease and are they aware of their place in the wider world? An apparent innocence of play (e.g. *Woman sitting on a swing*, Fig. 31) is shaken by the introduction of external threats, responsibilities, lack of protection and the implicit dangers of sexual awakening.

The second motif of inwardness morphs into playful invisibility and stubborn or confused withdrawnness. *Monument for Damian* (2008, Part 1, Plates 66-72), *Waiting* (2009, Part 1 Plates 25-30) and *Dunno* (2016, Part 1 Plates 73-79) take

the gaze pinned down (e.g. Ghost, Fig. 58) and introduce ambiguity and doubt. My sculpture blocks out the outside world with boxes or blindfolds. They refuse purposefully, rather than absent-mindedly, to recognise the outside world and appear caught in the dialectic push and pull between certainty as a future state and the uncertainty of the now.

Boy with knife (Part 1 Plates 97, 98), If only (2016, Part 1 Plates 91-96), Sleeping Beauty (2015, Part 1 Plates 83-90) and Boy with jacket (2002, Part 1 Plates 80-82) expand and add to the third motif of physical vulnerability. Their overarching emphasis lies in capturing the moment of imminent vulnerability that is latent in the transition from childhood to adulthood in contemporary settings. They embody the fragility that co-exists alongside psychological immaturity, uncertainty about self, the body and the perception of the self through others. The figures may initially impress as passive, helpless and impaled, however, they are 'not quite there yet.' They are shown at the tipping point where death, physical violence or sexual exploitation are visualised as potentiality rather than actuality.

## Endnotes

1 *Lord of the flies*, 1963. [Film] Directed by Peter Brook, UK: British Lion, based on William Golding *Lord of the flies*, Faber and Faber, UK, 1954.

2 Wood, S., *The Republic of Trees*, 2005, Faber and Faber, UK.

3 Rousseau, J-J., *Du contrat social ou Principes du droit politique*, 1762, France.

4 Butler, S., *The Elephant in the Moon*, poem, c1670, includes the line "shut between The two glass windows in restraint, Was swell'd into an elephant, ... A silly mouse ; this mouse, as strange, Brought forth a mountain in exchange."

5 Boyce, F.C., *Millions*, 2004, MacMillan, London.

6 Sarah Fisher (Director of Open Eye Gallery, Liverpool) and Ian Rawlinson (Head of MA/MFA at Manchester Metropolitan University) both commented independently at the exhibition preview how much the yellow statue had crystallised this very special and magic moment of completely absorbed play that they had witnessed as parents.

7 *Mapping UK's teen murder toll*, BBC News, online, available at: <https://tinyurl.com/brocuq> [accessed 13.4.2017].



8 Bettelheim, B., *The Uses of Enchantment: The Meaning and Importance of Fairy Tales*, 1991, Penguin Books.

9 Von Franz, M-L., *The Interpretation of Fairy Tales*, 1996, Shambhala Publications Inc, Colorado.

10 *Rochdale grooming case: nine men jailed for up to 25 years each*, 2016, The Guardian, online, available at: <https://tinyurl.com/hhkeh5d> [accessed 16.4.2017].

11 *Professionals blamed Oxfordshire girls for their sexual abuse, report finds*, 2016, The Guardian, online, available at: <https://tinyurl.com/myk6vbk> [accessed 16.4.2017].

12 Gliga, T., *The 'Knife Crime' phenomenon - A psychological perspective on youth knife culture*, date unknown, BPS Parliamentary Office, online, available at: <https://tinyurl.com/k5e38n6> [accessed 13.4.2017].

13 *ibid* p5.

## **Chapter 4 – Celebrating waiting: context, development and interpretation of *Just wait for me* (2012-13)**

Having interpreted the exhibited work in Chapter 3, this chapter focuses on *Just wait for me* (2012-13) developed for Central Park in Wallasey. The primary focus of the research is the representation of youth through sculpture, the particular nature of *Just wait for me* (2012-13) deems it necessary to consider the important notions of participation and site-specificity in public art and this will be done in relation to the writings of Malcolm Miles, Miwon Kwon, Claire Bishop, Grant Kester and the UK's first recognised Town Artist, David Harding. The chapter commences with reflections on site-specificity and public art and is followed by an analysis of existing sculptural representations of youth on Merseyside (4.1.1.) and an extrapolation of the features and undercurrents of the specific site in Central Park (4.1.2). Following on from this, a short recourse into participation in contemporary art practices (4.2), including examples of artworks created with young people on Merseyside, leads into subchapters on working with specific agencies including Friends of the Park, Wirral Council and the Steering Group (4.2.1) and workshops with young people (4.2.2).

### **4.1 Site-specificity and public art.**

The terms site-specific, social art and public art have been widely used since the late 1960s and a full exploration of the practices developed under these terms lies outwith the remit of this research. Nonetheless, for the development of my argument it is necessary to sketch out key voices from the discussions.

Arnold Hauser locates the beginnings of the separation of sculpture from architecture, that is, a splitting from its specific location and site, as early as 400BC. Due to the lack of an extensive temple building programme by the Athenian state, sculptors turned to private orders, resulting in the development of statuary which were “smaller size, more intimate in character and of a more readily movable type.”<sup>1</sup> Though the term site-specific entered art discourse in the late 1960s, the underpinning ideas around the relationship between artwork, site and site's usage is intrinsic to the history of *all* objects, sculpture and architecture. Lucy Lippard's short definition of public art includes the ingredients of audience, environment and art of any type. She writes, with my own italics inserted, that public art is “accessible

art of any species that cares about, challenges, involves and consults the audience *for* or *with whom* it is made, respecting community and environment...” in which any species of art includes “permanent or ephemeral, object and performance, preferably interdisciplinary, democratic, sometimes functional or didactic, a public art exists in the hearts, minds, ideologies and educations of its audience as well as in their physical, sensuous experience.”<sup>2</sup>

In the USA, the background for this enthusiasm for public art and *for whom or with whom it is made* is understood when considering the first New Deal Programme of the 1930s Depression period. The New Deal promoted art production in relation to specific sites and communities through the state-sponsored Federal Art Project (FAP) founded in 1935 under the directorship of Holger Cahill. FAP sought to bring art and artists into the everyday life of communities through the creation of community art centres, exhibitions, classes and Public Works of Art (PWAP). This *Art for the Millions*<sup>3</sup> must be understood in the context of an economic depression and the rise of art as propaganda, primarily in Fascist Germany and Italy. The overarching aim of these various Federal projects (FAP, WPA, PWAP) was to support artists by re-connecting art to the whole community and by making art participation possible for everybody. Cahill, influenced by the thinking of John Dewey, believed that this newly produced American Art would guide the American People by bringing order, design and harmony into society through the development of forms, symbols and allegories that revealed the character of American life and people; symbolic acts of renewal that resonate with the development of *Just wait for me* (2012-13).

The New Deal was abandoned in 1943 but in the post-war period, Baltimore became the first American state to introduce the *1% for Art Scheme* that was rolled out from the 1970s onwards as the Federal *Percent-for-Arts* programme, binding public artworks to new urban development budgets. Since then, the discourse on public art has also become a discussion around site-specificity and funding policies. As mentioned in relation to László (Peter) Peri’s work (see 2.1), the publically-funded school and housing building programme of post-war Britain echoed the belief in the harmonising, uplifting and aspirational potential of art for specific sites and diverse communities.

Miwon Kwon’s clipped genealogy of site-specific public art argues that the

changing conceptualisation of site-specificity in the public art context “indexes the changing criteria by which an artwork’s public relevance and its democratic sociopolitical ambitions have been imagined.”<sup>4</sup> She proposes a trajectory that moves from ‘plonking’ or parachuting large-scale abstract or semi-abstract sculpture onto American Plazas in an attempt to humanise the harsh reality of the modernist city, an approach exemplified by Alexander Calder’s *La Grande Vitesse* (1967), through to more design-orientated urban sculpture foregrounded in the 1980s by Scott Burton, Mary Miss and Nancy Holt, where artworks morph into landscaped environments, towards a more situation-specific approach. Kwon progresses her thinking towards a concept of site-specificity “distinguished by foregrounding social issues and political activism, and/or for engaging ‘community collaboration’”<sup>5</sup> with artists such as Suzanne Lacy, Tim Rollins, John Ahearn, Daniel Martinez in the USA and Loraine Leeson, to name a few. This fusion of activism and community collaboration came to acclaimed prominence in the USA in the seminal 1992-93 *Culture in Action: New Public Art in Chicago* exhibition curated by Mary Jane Jacob at Sculpture Chicago and in Germany with neighborhood projects such as *Park Fiction* (1994). Since the mid-nineties, the nature of ‘community collaboration’, site and the role and identity of the artist have been subjected to increased levels of ‘professionalisation.’ Bishop, Harding and Kwon in particular warn and partially condemn practices that are based on an overtly administrative or prescriptive approach, that Kwon calls *curatorial assignments*.<sup>6</sup> These approaches include a lack of consultation, most often discussed in relation to Richard Serra’s *Tilted Arch* (1981), or a misunderstood local matching of local artist and local site as in John Ahearn’s South Bronx sculpture commission (1991) or a racially driven match making as exemplified in the commissioning opportunity for Renée Green to develop work with African-American communities in Chicago as part of the *Culture in Action* (1993) which Green turned down on the grounds of being racially reductive.<sup>7</sup>

Despite persuasively arguing the trajectory from artwork as a finite object on a site towards art as participatory process and collaboration within issue-specific settings, Kwon overlooks a broader co-existence of approaches to site-specificity and also, as Claire Bishop observes, ignores a much longer history of participation and community art within the context of public art. The approaches to site-specificity in the UK for example as heralded by David Harding, Stephen Willats, Artist Placement Group and Loraine Leeson included similar radical ideas to those first



voiced in the 1930s WPA programme including collaborations between the artist and the public *for and with* which they work, an empathic and deep knowledge of the particular site and the socio-political context of its users and a spirit of cooperative learning and sharing.<sup>8</sup>

Whilst the resulting artistic practices ranged from temporary and permanent artworks to advisory roles, the approach was underpinned by the core beliefs on the part of the artists, that art and especially public art is more than putting sculpture on grass and that successful public art depends on “real solutions, integrated into the conceptual fabric of a place.”<sup>9</sup> To distinguish on a critical level between art that was shown outdoors and art that was commissioned or conceived from the outset for a public (outdoor) space, the term site-specific became increasingly important in the British context to relate art to place and place to identity, a topic I shall return to in my conclusion. Miles writes in 1989 that the role of art is to transform spaces into places and the public into people, which entails a merging of individual with common interests without contradiction: “art has this: it is personal, and shared.”<sup>10</sup> By referencing artistic practices such as Giotto’s fresco cycle in the Scrovegni Chapel, Padua and Jochen Gerz’s invisible *Monument against Fascism* (1986–93), Miles ascertains that there is no absolute formula in the relation to site. To confer identity upon a place, he proposes, requires an understanding of the three main aspects: the physical location, the people who use the space and the local history. What has been radically challenged, by prominent artists such as Jochen Gerz, is the level of certainty in relation to local history, identity and site. His seminal works to date, including the *Bremer Stadtbefragung* discussed in the next Chapter, confront culturally dominant narratives, not only in relation to site and history but also in relation to monumental sculpture and the spectacle.

As Bishop, Kester, Kwon and Miles agree, concentrating on the ‘specific’ aspects of the term site-specific can make critical evaluation cumbersome and this difficulty forces these authors to adopt an illuminating case study approach to examine particular artworks developed under distinct conditions for highly unique social and temporal situations. Artists’ approaches are then reframed within the context of the changing aims and objectives of state funding for the arts through Federal (USA) and Arts Council and Lottery Funding (UK) for example which, as Bishop points out, have evolved with the changing rhetoric of the ruling Governments.

Prior to the increasing professionalisation of the sector, Harding reminds us that “the attempts by artists to shift art out of the gallery and onto the streets in the 1960s were not simply about changing the location of where art could be viewed, but were about changing art itself, broadening its influences, born of democratic urges, and attesting, not that art was good for society, but that art was part of society and its systems.”<sup>11</sup> Despite the growth in art bureaucracy with its detrimental effect on the artists and a neutralisation in the development of public art, Harding remains an optimist and concludes that in a “very public way, the art can enrich a city, reinforce its culture, create identity, give rise to myth and humour, encourage risk, represent diversity, give voice to the unsung and allow us to remember.”<sup>12</sup>

Sara Selwood and Malcolm Miles list the empirical benefits of public and site-specific art as regeneration, lifting expectations and providing a sense of place and identity. Bishop, Miles and Harding reflect on the connection between various conceptual realities of art in the public domain, including their site and community settings, the curatorial concepts and the changing funding landscape. Not doubting the significant contributions made by Suzanne Lacy, Paul Tereul, Iñigo Manglano-Ovalle and Tony Streit (Street-Level Youth Media) in *Culture in Action: New Public Art in Chicago* (1992-93), Wochenklausur and Superflex in shifting the discourse from permanent public site-specific sculptures towards site and community specific interventions (both temporary and permanent), they have in themselves evolved out of community art and grassroots community action and require a critical reception that not only takes community art into account, but also their complicity with the aims of their funders and curators, which seek to make use of art as a tool or vehicle to increase employability, minimise crime, foster aspiration for the *excluded minorities*, to enhance ‘community cohesion’ or to address social isolation. The funding of artworks that support the ‘betterment of society’ is far from new. Kester suggests that the shift from finite single authored objects to dialogical practices is a move away from the idea of the artist as single author and producer of enlightened objects for specific sites to that of the artist as facilitator of interactive processes embedded in various social fields. In the context of radical neo-liberalism that believes in the monetary value of everything, including young people as discussed in the Introduction, whilst simultaneously allocating responsibility to the smallest unit (the individual), Kester understands dialogical art as a critical counter point and a necessary force for good.

Bishop in turn questions such an evangelical approach, whilst simultaneously acknowledging that although projects such as Superflex's *Superchannel: tenantspin* (commissioned by FACT in partnership with the Liverpool Housing Action Trust, 2001-13), Jeanne van Heeswijk's *2up2down* (Liverpool Biennial, 2011-4), Thomas Hirschhorn's *Bataille Monument* (Documenta, 2002) and more recently Assemble's *Granby Workshop* (Liverpool Biennial, 2015) focus on communicative processes in various fixed or unfixed community settings, they are never really without 'objects' or other aesthetic framing devices, nor can they be understood without seeing the signature of the individual author/artist and his/her conceptual idea formulated prior to the specific engagement with a particular community and/or site. Their collectively-driven work derives from site-specific practices and alternative pedagogic and grassroots initiatives and Bishop concludes with a cautionary note for all art, especially site- and/or situation-specific activist art for "At a certain point, art has to hand over to other institutions if social change is to be achieved: it is not enough to keep producing activist *art*."<sup>13</sup> In other words, art can set provocative, challenging or inspiring impulses, but should not be mistaken for a cure to all ills or as surrogate for much needed real social and political change. Kwon and Bishop both argue that the new type of site-specific exhibitions such as Skulptur Projekte Münster (1987) or Culture in Action (1992-93) influenced the emerging global contemporary art Biennials' definition of site. Site was to become addressed as "a *socially* constituted phenomenon, rather than as a formal or phenomenological entity."<sup>14</sup> According to Bishop, site, as an evocative formal backdrop for work imbued with historical resonance, became replaced by a site-specificity that is project-based and embeds the artist in a social field. Within the context of Merseyside for example, the Liverpool Biennial and its partner institutions Tate Liverpool and FACT followed this new concept of site by inviting and commissioning Superflex, Jeanne van Heeswijk and Assemble to develop new work within prescribed social fields in economically disadvantaged neighbourhoods. Without going into too much detail about these projects, I would like to focus on their commonality in relation to the process of creation, site, situation and community specificity. These artworks, together with the existing sculptural representations of youth on Merseyside that I shall consider shortly, provide the immediate context for *Just wait for me* (2012-13). Firstly, all three projects were situated in 'disadvantaged' neighbourhoods in Merseyside (including Aintree, Kensington, Everton and Toxteth) during and after the vacuum created by the policies of the Housing Market Renewal Initiative (HMRI)

and the Liverpool Housing Action Trust (LHAT). Secondly, all three projects were commissioned by major institutions such as the Liverpool Biennial or FACT. Dutch artist Van Heeswijk, Danes Superflex and London-based Assemble were 'brought in' from the outside, and the aim of all three projects was to initiate a framework that would encourage people "to become active citizens and enact social change within their own communities."<sup>15</sup> Thus *site* was not only contested site, but also an inhabited or peopled site.

Jeanne van Heeswijk's original brief was to develop a project with and for NEET (Young People Not in Education, Employment or Training). Superflex originally aimed to engage the largely elderly population of sixty-seven high-rise buildings earmarked for destruction while also developing Superchannels specifically with young people. Assemble were invited to Liverpool to engage with the fragile beginnings of a community self-initiated survival scheme. Beyond substantial funding, all three projects had at least one additional Liverpool-based artist or architect and housing officer aligned to it and an institutional project manager. Van Heeswijk provides detailed online accounts of the processes underpinning *2up2down* (2011-14) which give insight into the relationship between local experts, other local interests and the role of the artist in re-imagining social spaces. On her first visit she was accompanied by an artist who was born and raised in the area, and although she was "reluctant to give me the nitty-gritty details of what it meant to grow up there, her way of formulating the tensions and conflicts in the area are a great insight."<sup>16</sup> Van Heeswijk mentions numerous meetings with various stakeholders that were skillfully 'orchestrated' by the Biennial staff with whom she had an ongoing relationship. Paul Kelly was the community development officer that first facilitated the *tenantspin* (2001-13) project and his work straddled the Biennial and the Housing sector; van Heeswijk comments that Kelly "thought that it might be interesting for me to come and see the impact of the Housing Market Renewal programme and what was going on in Liverpool."<sup>17</sup>

What also distinguishes all three projects is their 'longevity.' *2up2down* (2011-14) spanned a co-production process between 2011-14 and has moved into a new phase following the slow withdrawal of Biennial support; it is now established as the Homebaked Cooperative Anfield Limited. The commission that brought Assemble together with the *Granby Workshop* (2015) social enterprise, comprising residents



of the Granby neighbourhood in Toxteth, gained the Turner Prize award in 2015 and subsequently increased the success of the Workshop and their bespoke architectural ceramics. This in turn added exposure to a more-than-fifteen-year long fight of a small number of local residents against the total destruction of their neighborhood. Whilst Assemble and van Heeswijk developed their projects toward the destructive end-period of the Housing Market Renewal Initiative, connecting with existing small pockets of 'local resistance', Superflex's *tenantspin* (2001-13) was situated at the beginning of this process, with the aim of connecting communities that were dispersed through the destruction of the high-rise flats as part of the LHAT programme. Unlike the other two projects that are sited in the last few buildings and community pockets which could be saved from destruction, *tenantspin* (2001-13) was an online community TV channel, programmed weekly for fifteen years by the tenants who were displaced, working under the support and guidance of local artist Alan Dunn.

All three projects' legacy far outlived the original expected timespan of the commissioning institutions and the time commitment of the artist or groups involved. Project managers, active participants and local artists developed a variety of strategies to change, adapt and to build on the initial project. It shouldn't be forgotten however that the site-specific nature of these projects was uniquely connected to endangered sites and communities in the shadow of deeply problematic and destructive LHAT and HMRI schemes. Within this context, the housing sector in Liverpool had huge funds to 'throw at' agencies such as the Biennial to develop engagement projects, rather than the Biennial selecting housing partners as opposed to, for example, health or education. Pertinently, once the housing and regeneration money (including the North West Development Agency funding) 'dried up', agencies such as the Biennial did indeed turn to health partners and then young people for jointly-funded projects.

And what is left of these projects? *tenantspin* (2001-13) marked its last broadcast in 2013 with an archival show at FACT, *Homebaked* operates as a local business and the *Granby Workshop* (2015) is exhibiting at the Venice Architecture Biennial. These are worthy and important projects but in relation to my research, there is a gap in knowledge of expanding our understanding of site, developing new representations of youth that learn from Antiquity and creating a hybrid method for local artists working with local young people in situations in which 'difference' can

still be a strength.

My brief review of the often overlapping terms site-specificity and public art concludes by revisiting Lippard's open definition of ephemeral and permanent art of any kind and a public for or with whom it is made, enriching physical and sensual experiences. This definition has the advantage of being *inclusive*, akin to a shared space of thinking and sanctuary such as a public library or park and allows one to consider works of a social nature from both the past and present. This is the important proposition for my research and in this climate, I will now focus on Merseyside to analyse the existing sculptural representations of youth in the region dating back to 1854 (4.1.1.) before extrapolating features and undercurrents of the specific site of *Just wait for me* (2012-13) in Central Park (4.1.2).

#### **4.1.1 Sculptural representations of youth on Merseyside.**

Merseyside has a large number of statues and monuments and a substantial catalogue of temporary outdoor artworks, particularly those developed by the Liverpool Biennial of Contemporary Art since 1999. These are recorded in *Public Sculpture of Cheshire and Merseyside*, *Public Sculpture of Liverpool* and the online Biennial archive.<sup>18</sup> In the context of this research, only the permanent public artworks that represent young people are of relevance. Prior to the inauguration of *Just wait for me* (2012-13), Merseyside had a total of six permanent statues in the public realm that represented youth and which are sited in either an educational setting or in a communal recreational context. The locations of these works are shown on the map in p.112.

#### 4.1.1.1 Youth as carriers of the future Empire.

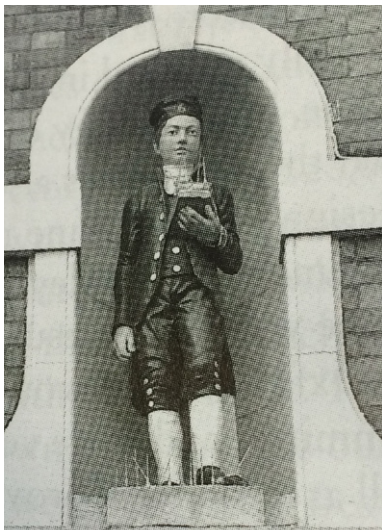

Fig. 87 Edward Richardson *Bluecoat School boy* (1854). Image from *Public Sculpture of Cheshire and Merseyside*, 2012, Liverpool University Press, Liverpool.

Located above the entrance of the Bluecoat School in Chester in an architectural niche, Edward Richardson's painted stone statue *Bluecoat School boy* (1854 Fig. 87) represents John Coppack, a pupil there between 1853-1854. The fourteen-year-old boy is shown in school uniform holding a book in his right hand at chest level as his other arm dangles at the side of his body. Wide-eyed and with a relaxed positioning of his feet, he conveys an optimistic confidence. His eyes are directed into the distance and one eyebrow is raised in assured confidence about his future beyond these academic gates. This polychromatic statue visualises the purpose of the building, namely the education of boys. The confident air emitting from his upright posture, attire and gaze also suggests that the education at the Bluecoat is an empowering experience.



Fig. 88 Frederick William Pomeroy *Navigation and Learning (detail)* (1902). Image by Brigitte Jurack

In the second example of an educational context, two ornate lamp standards top the stone entrance posts outside the imposing main entrance of the former College of Technology on William Brown Street in Liverpool city centre. Frederick William Pomeroy designed the flute column posts that are topped by two downward-looking figures (1902, Fig. 88), a young male on one side and a young female on the other. The bronze figures are smaller than life-size and have a beautifully weathered green patina. Author Terry Cavanagh suggests a personified allegorical reading of these two statues, whereby the male youth represents *Navigation* (1902, Fig. 88) and the young female *Learning*. Similar to *Bluecoat School boy* (1854 Fig. 87), the prominent position of these two statues outside the main entrance of a College of Technology is important as all college students would have to pass between them.

The windswept and very actively striding statue of the boy, with one foot even going over the edge of the plinth, has been particularly significant during the development of *Just wait for me* (2012-13). The deep undercuts of his coat, hood, collar and ruffled sleeves all create tremendous shadows and blocks of darkness. These dramatically offset the small hands, legs and delicate features of the face in a very energetic way. The statue emits a sense of drama and adventure with its oversized coat and delicately boned boy. Counterbalancing his active energy is the young female statue, centered on the plinth in a floor length dress. She too wears a garment that creates dramatic shadows as very large sleeve openings reveal her lower arms and hands. One of her hands seems to hold a board of some kind. Her movements are less outward going. Her gaze and body poise are directed towards



Fig. 89 Edward Carter Preston's *Monument to the world Boy Scout Jamboree* (1930-31). Image by Brigitte Jurack.

the space created between the board and her own body. Together, these two statues send out a clear message around the aspirational future bestowed on the young. They are the carriers of the light both literally and metaphorically and their education in this new educational establishment is a warrant for the future of The Empire.

Edward Carter Preston's *Monument to the world Boy Scout Jamboree* (1930-3, Fig. 89) has lost its original site context completely and, unlike the first two examples, commemorates a one-off temporary event organised by the Scout movement for Arrowe

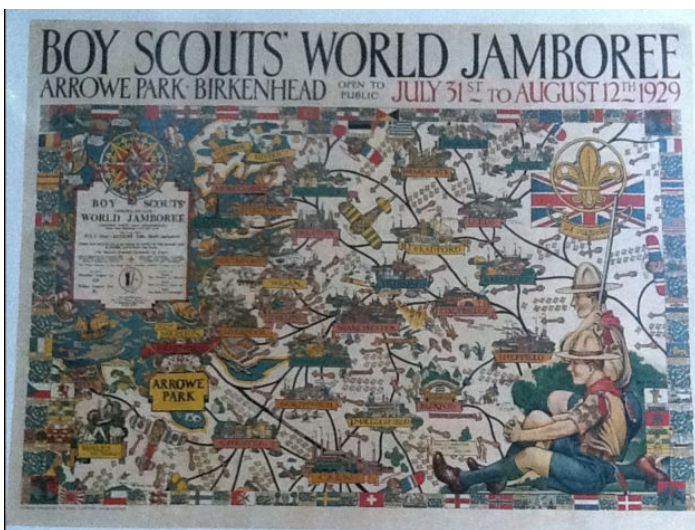

Fig. 93 *Boy Scout's World Jamboree poster* (1929). Image from <https://tinyurl.com/zmvljnz>.

Park on the Wirral in 1929. "It was called the Coming of Age Jamboree and celebrated the twenty-first anniversary of the founding of the movement in Birkenhead. Over 50,000 Boy Scouts and about 320,000 visitors from all over the world, including the Prince of Wales, were present."<sup>19</sup> Two posters (1929, Fig. 93) on public display





Fig. 90 William Gascombe John *Port Sunlight war memorial*, (1916-21). Image from <https://tinyurl.com/j7skzde>.



Fig. 91 Sir George Frampton *Peter Pan* (1912). Image from <https://tinyurl.com/zmsx7qz>.



Fig. 92 Diane Gorvin *Bo Peep and her sheep* (1985). Image from [bewsgorvin.co.uk](http://bewsgorvin.co.uk).

at Birkenhead Central Library illustrate the magnitude of the event that attracted delegates from forty-one countries to the Wirral. The event was open to the public and included international campfires, mass displays of historical pageants, folk dancing, Highland Pipes and sing-songs. Carter's statue commemorates this powerful event that would have allowed individual Scouts to experience being part of a world movement and the 'power of numbers' and to feel a sense of internationalism. Today, the rather neglected monument does not reflect the ambition of the Jamboree, but the figure of a singular uniformed Boy Scout nevertheless marks this remarkable event. The site of the Jamboree has since been absorbed into a hospital complex and the statue relocated to an approach road. Carter Preston's statue is unique since it marks and celebrates a leisure event rather than an educational process, and an event that in itself was organised by and for young people.

#### 4.1.1.2 Youth as carriers of innocence.

The first three examples celebrate youth as 'future carriers' and embody manners in which education and organised leisure time are intended as empowering young people to become desirable stakeholders in the future. Youth features as part of an intergenerational community in William Gascombe John's *Port Sunlight War Memorial* (1916-21, Fig. 90). This memorial incorporates a high number of children and adolescent boys and girls, both in relief and in the round, as part of larger figurative group. Conceived and developed during WW1, its main subject is the defence of the home. Art historian Ann Compton notes that the unusual and powerful iconography of this monument

results from the commissioner Lord Lever's vision of creating social harmony and mutual improvement within his ideal village.<sup>20</sup> The threat of the German invasion of the Wirral is seen as an attack on the whole community including children and women. In the monument, younger boys and girls stand facing the enemy and present wreaths and garlands in memory of the fallen. Nearby, a Boy Scout stands alongside an armed soldier.

Considering the unique setting and patronage of the monument, it is clear that the young people represented here are part of an intergenerational community brought together around a common purpose. These statues represent men, women, children and adolescent boys and girls of the Port Sunlight community and writer Holbrook Jackson sees the children as symbolic figures that represent the gratitude of future generations.<sup>21</sup> The monument has a green weathered patina state that enhances the drama of the scene through the surface's interplay with the atmospheric light, creating an eerie and slightly disturbing feel in this quiet suburban setting.

The final two statues on Merseyside that represent youth are set in the recreational contexts of Sefton Park and Birchwood Forest. Sir George Frampton's bronze *Peter Pan* (1912, Fig. 91) has been located in Sefton Park in Liverpool since 1929. Towering above a bronze mountain landscape that is heaving with rabbits, squirrels, fairies and mice, the fictional character of the boy who never grew up is shown striding with arms wide open and playing the flute. Appropriating James Matthew Barrie's story of *Peter Pan, the boy who wouldn't grow up* (c1904), the statue shows a life-size boy who appears so fearlessly cocky and of free spirit that he saunters dreamily while communicating with animals, fairies and humans. Diane Gorvin's *Bo Peep and her sheep* (1985, Fig. 92) was commissioned for Birchwood Forest Park as an entertaining piece to be used by the Park Rangers in projects with children, encouraging them and other forest visitors to explore the woodlands and 'find the sheep' that were scattered around. Dressed in a long flowing dress that trails along the ground, her hair tied in a bob and her left hand at her hip, the bronze shows a late adolescent girl with a flock of stone-cast sheep. Aside from the commissioning remit, the actual facial expression of the figure suggests a kind of slight annoyance or *ennui*, as if to suggest that she cannot really be bothered to care for the sheep anymore. Similar to the Pinboard 2 sculpture discussed Chapter 2, she omits a sense of self-absorbed inwardness.

#### 4.1.2 Features and undercurrents of the specific site in Central Park.



Fig. 94 Liscard Hall (1835), Central Park. Image from <https://tinyurl.com/klzouq4>.

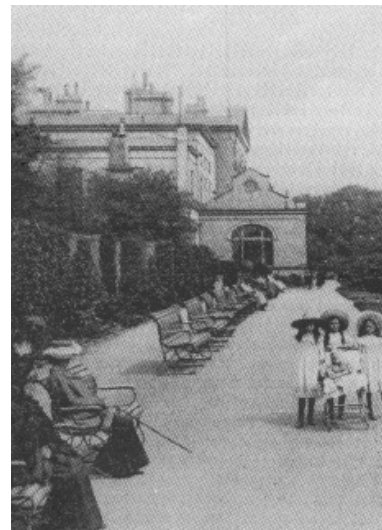

Fig. 96 Liscard Hall. Image courtesy of Friends of Wallasey Art School, Friends Reunited, 2000-2016.

The site chosen for *Just wait for me* (2012-13) is the plot of land where the former Liscard Hall (Figs. 94, 96) stood in the inner city Central Park, Wallasey, on the east coast of the Wirral Peninsula. Central Park is medium-sized and surrounded by low-rise Victorian terraces of the neighbouring wards of Seacombe and Liscard.<sup>22</sup> It is the only park within these two wards and is sandwiched between recent redevelopments at the coastal New Brighton and the neighbourhood renewal area of Seacombe. Central Park is heavily used by all ages and population groups for children's play, dog walking and organised sport such as cricket, football, bowling and fishing. A walled garden houses a small social enterprise café that provides tea and coffee for outdoor consumption only.



Fig. 95 Boer War Statue (1921), Central Park. Image from <https://tinyurl.com/jt9gksu>.

Central Park also comprises fishing ponds, playing fields, neglected basketball court, functioning football cage, children's playground, large boarded-up church, former show farm occupied by machinery of Wirral Council's Parks and Garden Department, cricket ground and clubhouse, bowling greens, allotments and a Boer War memorial (Fig. 95) with the inscription *Erected to the memory of the Wallasey men who lost their lives in the South African War 1899-1902*. This statue is important in the context of my research as it



represents for local people the 'acceptable' face of public sculpture. It has reason and purpose, it is fenced off and the figure is high up.

In the middle of Central Park stood a large Grade II listed neo-classical house built in 1835 by the retired slave trader and privateer Sir John Tobin. This building, known locally as Liscard Hall, was purchased by Wallasey Local Board in 1890 to convert it into a college for science and art to be known as The Liscard Science and Art College.<sup>23</sup> The reasons for this development included the fact that the area has experienced a large influx of population following the expansion of the nearby docks. The College trained engineering students and provided studios in which students learned to sketch from life or nature and study technical drawing, painting, printmaking, typography and illustration. Teaching commenced before WWI to a small group of students including landscape painters Walter J Watson (1879-1979) and John Ernest Aitkin (1881-1957). In the post-War years, partly with the decline in local industry, the institution was renamed Wallasey School of Art and celebrated



Fig. 97 John Addyman. Image from <https://tinyurl.com/hs4rmps>.



Fig. 98 Wallasey School of Art (c1968). Image courtesy of Friends of Wallasey Art School, Friends Reunited, 2000-2016.

artists such as Frances Macdonald (1914-2002), Albert Richards (1919-1945), George Wallace Jardine (1920-2002) and Raymond Moore (1920-1987) studied there between the Wars.<sup>24</sup> John Hirst Addyman (1929-2006, Fig. 97), known as *the rebel of Wallasey*, studied there between 1945-49.

Wallasey School of Art attracted those who dreamt of becoming artists, writers, musicians, actors, illustrators or designers; it appealed to those young people of Liscard and Wallasey who aspired to be different. The students in Central Park quickly gained a reputation for being wild and over the top, free and outrageous with their music, fashion



and art. They built floats for Rag Day Processions and joined their contemporaries on Hope Street in Liverpool. They dressed up, painted their belly buttons (Fig. 98) and formed bands.<sup>25</sup> The high calibre of practitioners connected with the site and its history helps during my negotiations with Wirral Council who are interested in somehow marking this local artistic heritage. By the mid-1980s, the golden era of Liscard Hall as Wallasey School of Art was over with the School relocated to nearby Withens Lane before becoming subsumed into the wider Wirral Metropolitan College campus. Liscard Hall was subsequently leased to Serve Wirral Training, a Government-funded Youth Training Scheme and this continued until their voluntary liquidation in 2003.



Fig. 99 Central Park fire (2008). Image from <https://tinyurl.com/znfsmwd>.



Fig. 100 Central Park after fire (2008). Image by Brigitte Jurack.

I moved to Liscard in 2003, buying a house five minutes from Central Park, but between 2003-8 Liscard Hall is a boarded up shell. On the night of Monday 7 July 2008, the building caught fire (Fig. 99). The local conservative MP Leah Fraser provided this response the next day, “While it looks like jobs are the cause of this fire, I’m afraid the council must also take some of the responsibility. The council has allowed this building to fall into disrepair. The problem started when the Government pulled funding for the local apprentice-training scheme that was using the building. Ever since then, the council has dithered in what to do with it – promises of ‘community use’ came to nothing and sadly, we can now see the result.”<sup>26</sup> The rubble of the building was fenced off, before being completely razed (Fig. 100).

For me, Liscard Hall was a sleeping giant and only twenty minutes by public

transport from Liverpool, a city that spent 2008 as European Capital of Culture. Whilst other parts of Britain were booming, the eastern shores of the Wirral Peninsula were in permanent economic decline. Photographing the rubble of Liscard Hall, only now illuminated by security lights, I captured the death of a future, a building used for over eighty years by young people as a place of education, imagination, rebellion and beat. The demolition was also the destruction of the powerful posture of the slave trader Tobyn, erasing a structure that served both feudal and egalitarian aspirations. Following the fire, fresh grass grew badly over the flattened ground, withering early in the summer due to the lack of irrigation. The dry grass covering the rubble became a constant reminder of an absence of future. What could grow in that void?

#### **4.2 Participation in contemporary art practices.**

The term 'participation' has been used widely in the discourse around contemporary art as artists and collectives such as the afore-mentioned Superflex, Wochenklausur, Suzanne Lacy, Thomas Hirschhorn and Renée Green gained critical recognition in the mid-1990s. Participation and engagement have evolved from the margins to the centre of many art institutions' agendas and include the more recent transformation of Middlesbrough Institute of Modern Art into a 'useful' Museum and an attempt at cataloguing 'useful art' through the open access online archive *Arte Útil* (2004) initiated by artist Tania Bruguera. Since its launch in 1999, the Liverpool Biennial, together with FACT and TATE Liverpool, has commissioned artists to create work with particular sections of the local population. These commissions were undertaken either as part of each institution's engagement programme or as part of the overall curatorial theme. Beyond the afore-mentioned *2up2down* (2011-14), *tenantspin* (2001-13) and *Granby Workshop* (2015), Dutch artist Rineke Dijkstra's *The Crazy House (Megan, Simon, Nicky, Philip, Dee)* (Liverpool Biennial, 2009), American Kristin Lucas' *Celebration for Breaking Routine* (FACT, 2003) and Glasgow-based Marvin Gaye Chetwynd's *Dogsy MA Bone* (Liverpool Biennial and METAL, 2016) provide further immediate context for *Just wait for me* (2012-13), sharing as they do the foundation of working with young people in Merseyside, and I shall reflect upon these shortly.

As discussed in 4.1, participation has much earlier roots. The drive towards

active participation in the USA began with the New Deal and in Europe it could be said to have its roots in Berthold Brecht's Epic Theatre and agit prop plays influenced by artists, writers and filmmakers of the Russian Revolution. These were driven by a desire to create non-bourgeois forms of art and theatre that would be immediate and experiential, accessible to all and would speak through or with the voices of the hitherto oppressed. In order to achieve this, Brecht believed in *aesthetic shock* or *dislocation* as a way of counteracting false reality conveyed by dominant cultural forms,<sup>27</sup> a strategy appropriated by artists coming together under the umbrellas of Dada, Surrealism, Situationism, the community art and activism in the late 1960s and early 1970s, Joseph Beuys' *Office for Direct Democracy* (1972) and what became termed 'participatory' or 'dialogical' art. The aesthetic and energy of agit prop and Brecht are prominent in all of Hirschhorn's *Monuments* (1999-) and Chetwynd's *Dogsy Ma Bone* (2016).

Less polemic but equally impactful in the context of the USA and recent art projects situated in social contexts such as the 'disadvantaged neighbourhoods' in Liverpool, Chicago or New York was John Dewey's idea of art as the most civilized form of communication and the best means for entering sympathetically into the deepest life experience of other people which lead to the creation of the first community art centres in the USA in the 1930s. However, in relation to site-specificity, *participation is also intrinsically part of the art object*. This is particularly apparent when looking at religious or pagan objects and statues that require 'hands-on' participation such as the Easter Processions in Sicily or Spain, or objects linked to *animation* as discussed in the context of the Swing Festival and the Ephidrismos statuettes (3.1). The relationship between the artistic practice and the other is a given. Nicolas Bourriaud writes "artistic practice is always a relationship with the other, at the same time as it represents a relationship with the world."<sup>28</sup> The manner in which participation shapes, enables, creates and partakes in the artistic practice has been more widely discussed in the current climate of 'post-studio' art practices, most notably those of the aforementioned group of artists (4.1) and others such as Rirkrit Tiravanija, Carsten Höller, Nils Norman and the performance group Foreign Investment, which I co-founded in 1996. The common thread through these diverse practices is the construction of models of sociability for producing human relations with the overarching aim of creating or facilitating functional models of interaction that seek to problematise and critique the spread of the monetary-based supplier/

client relations that have colonised every aspect of human life within societies that are based on neo-liberal economies.

In contrast to the often overwhelming complexities of modern life and social relations, the required participation is rather simple, often involving strategies used in community art, adventure playgrounds or self-help initiatives of the alternative scene of the late 1960s and early 1970s such as workshops, sharing and preparing meals, sharing home comforts, setting up discussion opportunities, initiating or facilitating social enterprises, self-help groups or alternative schools, building interactive play sculpture and tapping into modus operandi and aesthetics of community or amateur organisations such as community theatre, allotment associations or many other loosely defined social groups. Hirschhorn's monuments serve here as an excellent example. Totally committed to art in public spaces, he creates work for what he calls a 'non-exclusive public', such as one found in social housing schemes in Kassel or the Bronx. Hirschhorn's monuments combine construction, programming and performance and always include a series of talks, children's workshops, community theatre, poetry, philosophy sessions, community radio, party, café and a library within a set of roughly constructed temporary architectural spaces. Advocating the idea of 'presence and production' since the *Bateille Monument* (2002), the artist is on site and part of the production, performance and programming during the entire lifetime of its real existence. Whilst creating "truly participatory artworks"<sup>29</sup> Hirschhorn insists that decisions about the location is an artistic decision that cannot be taken by an institution nor an administration. In regard to authorship and collaboration Hirschhorn proposes provocatively the concept of "unshared authorship", meaning that he, the artist and the author of the monument has 100% responsibility for the work. Whilst the projects could not be realised without all those involved such as paid and unpaid members of the neighbourhood, neither the responsibility nor the understanding of the work are shared. However "the Other, the one taking the responsibility of the work also is equally author."<sup>30</sup>

Chetwynd's *Doggy Ma Bone* (2016) employs a similar approach to a carefully constructed makeshift 'improvisation' aesthetic directly referencing Brecht, the popular school musical *Bugsy Malone* and the cartoon character Betty Boop. Working with seventy-eight children and young people from Liverpool, the artwork consists of a musical in which the young people perform, a video of the musical,



hand-made props and costumes and a temporary auditorium. Teamwork and co-creation lie at the heart of *Dogsy Ma Bone* (2016), whereby Chetwynd takes on the role as director, enabling the children and young people to experience “a sense of enjoyment in the act of creativity.”<sup>31</sup> Like all Biennial engagement commissions, the project had a substantial production and facilitation team that included the Education curator Polly Brannan, Slice Fellow Alex Brewster and several partner schools, all arranged on behalf of the artist before she arrived.

Hirschhorn is clear that the first thing he does is ask for help during his fieldwork. “It is not me, the artist, who can help, or me the artist who has the pretension to help. It’s me the artist, who needs help. As the artist, I said: ‘I want to do a monument. Will you help me? If nobody helps me, I cannot do the work.’”<sup>32</sup> Having previously relied on family and friends as willing performers for her work, I would argue that Chetwynd too needed help from others, namely the children and teachers but also from the Biennial as part of their wider *Children’s Episode* programme.

These Merseyside illustrate Kester’s differentiation between two kinds of aesthetics of participation, one that is steeped in the modernist tradition of the artist as producer of objects and experiences, including participatory experiences, and a ‘dialogical aesthetic’ that is suggestive of an artist who is defined “in terms of openness, of listening, and of a willingness to accept a position of dependence and intersubjective vulnerability relative to the viewer or collaborator.”<sup>33</sup> The second artistic strategy is critical insofar as it anchors discourse not in some fixed representational order but in a process of open-ended dialogical interaction that is itself the “work” of art. In Kester’s view, this shift signals the departure from the idea of the artist as uniquely positioned to recognise defects and remedy, to the artist as somebody who comprehends the creative dimension of communal and collective processes. Thus, open-endedness and liberating possibilities no longer reside in the artwork as object, but in the very process of communication that ‘the artwork’ catalyses, making the participating people the medium of the work.

‘Socially-engaged’ practice invests in ‘structures’ that enable open-ended dialogical interactions. It is therefore crucial to ask who the participants of these ‘structures’ are and further more, who is gathering these participants together. Participants may well be incidental, but the projects discussed are linked to ‘bespoke’

participants such as social housing tenants (*tenantspin*, 2001-13), vulnerable women (Wochenklausur's *Shelter for drug addicted women*, 1994), young inner city people (Suzanne Lacy's *The Roof is on Fire*, 1993-1994), multi-cultural neighbourhoods (Foreign Investment's *Gold for Oslo*, 2010) or impoverished inner city areas (Assemble's *Granby Workshop*, 2015, and Hirschhorn's *Gramsci Monument*, 2013).

It should be noted that this hive of activity cannot be fully understood without mentioning Arts Council policies of social inclusion which have resulted in an overlapping of interests amongst agencies and coincided with the progressive reduction of state funding for open access and free amenities (e.g. community art centres, youth clubs, libraries). Under an agenda of social inclusion, art participation also means soft social engineering to diffuse community tensions, to expand art audiences and to colonise the marginal and disenfranchised through artistic collaboration. In this context, participatory practices have become increasingly professionalised through curatorial matchmaking, the employing of local brokers for international artists and teams of paid *project managers*. This however does not necessarily impact on the quality of the individual project, but it has impacted on the processes of communication and mediation between various stakeholders and funding. In contrast, the work of the first generation Town Artists such as David Harding and Stephen Willats and the catalytic impulses set by Joseph Beuys provide the sharpest critiques of the prevailing system of increased professionalisation; Harding and Willats completely self-initiated their *modus operandi* within particular local settings, whilst Beuys originated an ever more complex continuous and international discourse on ecology, economy and the free will partially subsidised by profits from art sales, his professorial salary and subscription schemes.

Kwon describes ways in which this curatorial professionalisation has led to two problematic underexposed concerns. Firstly, the assumption that 'community' is a social entity which *awaits outreach* and secondly that a partnership of 'appropriate' artist with 'appropriate' community leads to empowerment through the shaping of communicative processes within project-specific time frameworks. She warns that an uncritical use of the terms community and participation in relation to art runs the risk of mimicking neo-liberal economic agendas by providing a sticking-plaster approach to deep seated and systematic inequalities. Further, placing artists in 'marginalised' and 'voiceless communities' for the purpose of participatory events

could be understood as a new form of colonialisation, exploitation and reification of marginal and disenfranchised groups, not so dissimilar to the content of *genre painting* which afforded the bourgeoisie pictorial glimpses into the life of others.

Well-dressed visitors to Documenta 11 in 2003 were taxed to the housing scheme where the *Bataille Monument* (2003) existed, rebuilt anew every moment the local residents interacted in and with it. The contrast between the art tourist and what was happening in the *Bataille Monument* (2003) was instrumental in unmasking the 'exclusive public' and remained true to Brecht's ideas of aesthetic shock and dislocation.

Kester makes the case for a new form of aesthetic representation based on transformation through participation in the 'discursive space' and for Bishop neither participatory art per-se nor community involvement per-se are readymade solutions within a *society of the spectacle*. These practices too are uncertain and precarious and require performing and testing in their specific contexts. In those artworks referred to, people are the medium of art in the very act of participation (the event, project, workshop) which is also then mediated. She continues "Participatory art has always had a double ontological status: it is both an event in the world, and at one removed from it."<sup>34</sup> On the first level it communicates through the participants and on the second level to spectators. Bishop ascertains that it is this second level of communication that requires the mediating object, image or film that then permits the experience to have a purchase on the public imagination.

This second level of communication is what is left for the public to view in Dijkstra's and Lucas' work with young people in Liverpool. Again, commissioned by institutions, both international artists worked with the music and club scene of Liverpool. Lucas' *Celebrations for Breaking Routine* (2003) was initiated by the Collaboration Programme at FACT and involved the Venus Working Creatively with Young Women group in Bootle and three local girl bands, Venus, Exit3 and Flamingo 50, writing and recording songs based on their visions of the future: "The sometimes wistful, often defiant songs reflect the young women's concerns with the environment and global politics as well as personal dreams and aspirations."<sup>35</sup> The exhibition itself comprised video, live performance and an open air gig aesthetically framed with props and animated murals that projected Liverpool into a possible

future, a time when anything seems possible.

Dijkstra's video installation *The Crazy House (Megan, Simon, Nicky, Philip, Dee)* (2009) was developed as the three-channel video including *The Weeping Woman* (2009) commissioned by TATE Liverpool as part of the community engagement exhibition *The Fifth Floor: Ideas Taking Space* (2009). Whilst *The Weeping Woman* (2009) shows Liverpool school children talking about Picasso's painting *Weeping Woman* (1937), the video portraits of Megan, Simon, Nicky, Philip and Dee show them dancing to local club music in solitude in front of a white wall. The artist met the young people at the Liverpool disco known as Krazy House and filmed them at an improvised studio in the building itself. Dijkstra regards herself as a portrait artist where she seeks to encapsulate somebody being concentrated. Building a studio on location is part of her desire to have control whilst also not having control. The young people's participation in her work lies in the moment where they agree to go into the improvised studio to be filmed or photographed. They are firmly the 'subject' of the work and as the artist states, "I want to capture subjects in a specific state of being, I'm always looking for portraits that show a complex range of emotions."<sup>36</sup>

In Dijkstra's work the participation of the young people is on the level of the sitter for a portrait. The actual artworks, though initially commissioned and created and situated in specific locations of Liverpool, have been exhibited world wide, taking the awkward poses of teenagers in Liverpool nightclub fashion and freckled school children in ill fitting uniforms and broad accents to a global audience. Thus *site*, significant in the creation of the work, is irrelevant in regards to its understanding.

The inseparability of processes of participation and communication and product within public and site-specific art forms the starting point for my reflection on the context and processes behind *Just wait for me* (2012-13). The following sub-chapters return to the particular focus of my own sculptural work and having argued for artwork that is both imbued with a sense of participation and evolved for a highly specific site, I will now look at the various people and communicative processes that contributed to the development of the public work for Central Park. In doing so, I will make a case for a hybrid position whereby local and non-local, open-endedness and direction, knowing and not-knowing co-exist, and where *all* levels of communication



and participation use mediating frames such as mundane objects (tables, chairs, writing and craft materials) and activities (walking and meeting).

#### **4.2.1 Working with the Friends of Central Park, Wirral Council representatives and the Steering Group.**

Living within a five-minute walk from Central Park, I was curious to find out if Wirral Council had any plans to redevelop the scarred sight in a way, that would honour the past role Liscard Hall played as a place for young people, perhaps through the creation of a new youth centred area. By 2011 Wirral Council had neither commenced landscaping nor gone public about any plans to invest the insurance money from the destroyed Liscard Hall back into Central Park. In autumn 2010 I attended a Friends of Central Park meeting and it was evident even then that there were no intentions to create any youth friendly zone on the plot to honour the Hall's significance. Wirral Council did release plans for some basic landscaping in the context of more general upgrading of Central Park, including a green gym and refurbishment of the playground, but had no plans to involve an artist. With the vague notion of a public sculpture in my mind, I began some site research and started talking to various stakeholders, funders and the local youth centre in Wallasey, called The Hub.

Between autumn 2010 and the submission of a bid to Arts Council England's Grants for the Arts scheme in October 2011, I engaged in open communication with the Friends of Central Park, Jackie Smallwood (Senior Landscape Officer, Regeneration and Environment, Wirral Council) and the nearby Youth Centre. These exchanges were mediated through one-to-one meetings, poster presentations to the Friends of Central Park, hands-on scoping workshops at the Youth Hub (4.2.2.1) and a ballot on the most popular outdoor play sculpture environment during a Central Park Open Day.

At this point it should be noted, that whilst I was a resident of the area, my German accent and my profession marked me out as not being local (indigenous) or a 'typical' member of the community. The very fact, that I was introduced as artist shaped the expectation of all those involved. Everybody, from Councillor to young

person expected 'something artistic', which was outwith their perceived skill sets and expertise. In this sense, the local vicinity of the artist is no warrant for local shared identity. And every attempt at open-ended dialogue is curtailed from the onset by pre-existing expectations from those involved. Even if the communication began with an open-ended speculative curiosity in regard to the potential future of the site, the various conversations lead to a more clearly formulated set of ideas which were eventually discarded or pursued further on the grounds of their do-ability. That is, do-ability is considered in relation to the potential audience represented by those involved in the discourses and in relation to the ability of the artist to realise the idea.

With Wirral Council being drastically under-funded in regard to arts and culture, and indeed without a recognised Arts Officer, I anticipated that a bid to the Grants for the Arts scheme would stand a chance if backed by the Local Authority. I meet with Helen Wewiora (Relationship Manager, Arts Council England) and Jackie Smallwood (Senior Landscape Officer, Regeneration and Environment, Wirral Council) and with positive feedback on both accounts, I prepared an application (Part 3 p.2-22) for production costs, a modest fee and expenses. The bid was submitted on 24 October 2011 and a positive outcome announced on 27 January 2012.

I immediately put my plans into action, scheduling further workshops, this time with local schools, and forming a representative stakeholder team consisting of Jackie Smallwood, Colin Simpson (Curator and Keeper of the Williamson Art Gallery, Birkenhead, Wirral Council), Naomi Horlock (Learning & Participation Curator, Mostyn, Llandudno and Wirral resident), Chris Davies (Friends of Central Park) and Steve Chan (Deputy Head Universal Youth Support Service, Wirral Council). We met to plan and monitor the progress of the work, the engagement component, the installation, site landscaping design, signage and launch. The minutes from a selection of these meetings are included in Part 3 p.90-98. I invited all stakeholders into my studio in The Old Bakery that I had just purchased, making a further financial commitment to the area. Their eyes cast over the same pinboards of images referenced in Chapter 2 and they absorbed the humidity and light qualities of the studio described in Chapter 1.

None of the members of this stakeholder team had any previous specific experience of supporting a public sculpture project from inception to realisation, but each one had valuable expertise that contributed to the overall success of *Just wait for me* (2012-13). Colin Simpson edited the public information signage for

example, Chris Davies provided vital links to Friends of Central Park, facilitating two meetings at Central Park Cricket Club where the project was introduced and discussed with community stakeholders and Naomi Horlock undertook the intensive Evaluation Report (Part 3 p.41-73). Friends of Central Park also provided additional funds towards the project and Jackie Smallwood was the key contact within Wirral Council in supporting the project through releasing of funds and providing the overall landscaping plan for the site. Wirral Council youth workers acted as links to young people in The Hub and Central Park itself. Overall, as Horlock noted in her Evaluation Report that “there can be no doubt that the artist succeeded in engaging a wide range of groups locally and in particular the local young people.”<sup>37</sup>

#### **4.2.2 Workshops with young people.**

I planned and delivered a series of workshops for young people in both formal and informal settings during the preparation and completion stages of the project. The aims of these workshops were to raise awareness of the planned landscaping as well as my proposed artistic intervention. The workshops also allowed me to gather visual material that would potentially inform the final artwork and encouraged a sense of ‘ownership’ in relation to the planned transformation of the site. As a user of Central Park myself, I knew that the project needed local friends and champions in order to be accepted and looked after. It was important to involve some of the young people who used the site regularly in the early stages of the project development and validation of this process is demonstrated by the fact that the sculpture remains completely vandalism-free nearly six years after installation.

##### **4.2.2.1 The Hub.**

The Hub is Wirral Council-run open access drop-in facility for young people, open Mondays-Fridays between 5.30pm-9.30pm and situated five minutes from Central Park. Young people using The Hub also use Central Park for recreation and hanging out and floating youth workers visit Central Park regularly throughout the year during evening hours. The Hub’s prime function is to provide a safe and fair young people orientated environment for 12-18 year olds. A free open-access programme of leisure activities includes reality childcare training classes, street

dancing for young males, day trips to Alton Towers, band practice, computer games, pool, table tennis and a tea and soft drink bar managed by young people.

Between April 2011 and February 2012, I attended The Hub regularly on Wednesday evenings. Following two informal evening visits to meet potential participants, The Hub manager Lisa Joy (youth worker, Wirral Council) assisted me with and facilitates the subsequent workshops. On each occasion I was prepared to deliver a practical making workshop but this did not always take place as the young people attended The Hub for their leisure time and to socialise. The direction and focus of each forty-five minute workshops ranged from general scoping activities around what could be created on the site of Liscard Hall (Part 1 Plates 100,101), to more directed making sessions which sought to raise awareness of the symbolic potential of representational sculpture within the local context (Part 1 Plates 112,113). All the workshops (Part 3 p.86) were primarily focused on non-verbal activities of making statuettes and models and the delivery style varied according to settings and timing within the lifecycle of the project development. The workshops were internally advertised and open to all on an informal drop-in basis. Up to five young people attended regularly over a four-week period, while others attended once or twice.

I provided the loose structure for the workshops through the simple scoping question 'What kind of thing could be built on the cleared site of the former Liscard Hall in Central Park?' This sparked a creative process and relationship that flowed into the figurative work that greatly informed the final piece. All the workshops took place around a single table with materials provided for making objects and structures including clay, wax, paper, card and glue. This allowed for a "nonlinear, non discursive space in which to think in deep, messy, and meaningful ways."<sup>38</sup> On two occasions I set up the table in the shared communal area and this encouraged a very informal open atmosphere of interaction between active participants and contributing bystanders. On all other occasions the table was in a separate room and this permitted those wishing to participate to indicate to their peers that they are engaged in a more focused activity. These workshops gave the young people opportunities to juxtapose and connect items, thoughts, emotions and opinions in new and unique ways and during my time at The Hub, young people exchanged and shared their views over the use and misuse of Central Park. They openly reflected



upon the alleged youth vandalism that contributed to the destruction of Liscard Hall and detailed those places where they *sit off* (colloq. for *hang around*).

Having built up a level of trust with the young people, I introduced the notion of them working with clay. Many claimed never to have worked with this material and we began discussing the idea of a statue, one that better reflected their uses and visions of and for Central Park. Conversations across the table drifted from very personal teenage banter to serious discussions around community responsibility and the desire to make Central Park a nicer place. The workshops more than met their aims and gave me opportunities to gain insight into how some young people use and regard a local site and what visions they may have for its future. Both in the preparation for and drafting of my ACE application and also in the artistic development of *Just wait for me* (2012-13), these workshops were crucial for a number of reasons. In the portrayal of youth through sculpture, I was able to be amongst young people on a regular basis, listen to their conversations and banter and collect their visualisation of ideas for the Liscard Hall site. Towards the end of my time at The Hub, a group of adolescent male street dancers volunteered to perform some moves to be photographed for future use in the modelling sessions and one of the photos shows two dancers piggybacking each other in utter joy (Fig. 102).

Whilst the workshops never set out to design the actual sculpture, they did provide significant insights into the young peoples' relationships with each other

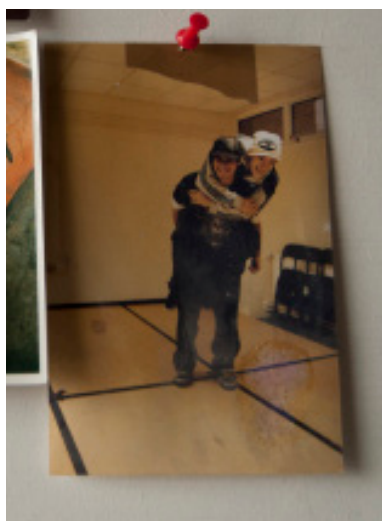

Fig. 102 The Hub Workshop (2011).  
Image by Brigitte Jurack.

and their leisure time use of Central Park. Witnessing the banter, the camaraderie, eavesdropping on their relationship dramas and being allowed to share their often-exaggerated bravado greatly influenced the overall project. The involvement of many young people is recognised by Wirral Council who reflected: "The main thing was the young peoples' involvement in the process ... I think it was really nice to see them getting involved and getting on board and getting interested, and sort of inspiring them as well; getting them to take ownership of something in the park as well ... if they're

trying to get something put in the park, you know, that's when we're normally getting involved with them, if it's a skate park or something like that, a lot of the time that's not always possible because of the finances involved ... it was a really good, timely project."<sup>39</sup>

#### 4.2.2.2 Schools.

Alongside the informal workshops in The Hub, and after the approval of the ACE application, I delivered a series of six workshops with forty-five young people from three local secondary schools, all within walking distance of Central Park. The young people were all aged 15-18 with the schools being St Mary's Catholic College, Weatherhead High School and The Oldershaw Academy. Each workshop took place within the school's art department and was facilitated by myself and one undergraduate Fine Art student from Manchester Metropolitan University who was responsible for IT support. During the workshops, the regular art teachers were not present. In two of the schools the workshops were held during the regular timetabled art lesson and in one school as an afterschool club. I noticed that the young people in all sessions were very highly motivated and participated with the utmost dedication and concentration. The aim of these workshops was to further raise awareness of representational sculpture as a medium that has the potential to represent the mood and feelings of young people whilst simultaneously informing participants about the forthcoming changes to the Liscard Hall site.



Fig. 101 Workshop - sculpture base (2011). Image by Brigitte Jurack.

To help achieve this, I structured the school workshops in three interlocking stages to include individual, partner and teamwork. Each workshop began with a small team brainstorming session on local public art: 'Have you noticed it? What might it be about? For whom is it meant?' This is supported by a handout (Part 3 p.87-89) stimulating a short reflection and feedback about the meaning of a set of provided images. All the participants recognised that a single gesture such as piggybacking could convey very different meanings and stories. I also included a quick-fire movement and

photographic session in which students in groups of four were asked to express one of the following feelings: sad, on top of the world, happy or loneliness. All participants were given cameras and within a highly energetic ten-minute period, they acted out different poses and photographed each other. The student assisted by printing out the photos the students had just taken and from these they made a selection as a starting point for some three-dimensional modelling.

Each student was provided with a plaster base (Fig. 101) that included a rudimentary wire, and some bright yellow Pelikan Nakiplast wax. They each worked for around thirty minutes modelling in the likeness of the photograph (Part 1 Plates 108,109,114-119). At the end of the sessions, the students documented their own work for tumblr and about half of them took their work home. Horlock quotes a teacher in her report: “Brigitte talked in the workshop about figures and poses and ... things that we just do naturally we see in kind of classical sculpture as well and she talked to them a little bit about that and then she just said to them ... just work in pairs, work in groups and try to show friendship, and different poses about friendship and dynamics ....”<sup>40</sup> When asked if she recalls her pupils’ comments at the time of the workshops, another teacher comments: “I remember them enjoying them. I remember them being really relaxed; we all sat there chatting about things ... I just remember it being a really nice experience and the girls enjoying the sessions ‘cause making’s so lovely and it was very detailed and some of them really got into it.”<sup>41</sup>

The yellow statuettes bear testament to the young peoples’ understanding that sculpture can express feelings, moods and desires and that figurative sculpture in the public realm can do more than commemorate war victims, heroes or local dignities. Both in the more informal Hub setting and these school contexts, the non-verbal making and the informal micro conversations during the making enabled the young people to become “primary informants of their own existence.”<sup>42</sup> A detailed evaluation of the school workshops, including views from the teachers, is included in the Evaluation Report (Part 3 p.41-73).

#### **4.2.2.3 Grundy Art Gallery.**

In January and February 2012 I had the opportunity to introduce young people to my solo-exhibition *Pink Parachute* at the Grundy Art Gallery in Blackpool. The exhibition included *Boy with mouse* (2009, Part 1 Plates 54-58) and a suite of plasteline statuettes (2009, Part 1 Plates 99,102-107, 110,111). The workshops at the exhibition followed the same structure as described in the school section with the main difference being that the participants were surrounded by my artworks. A small number of works produced by eighteen-year-old art students from Blackpool College (Part 1 Plates 104-107) and twelve-year-old students from Fleetwood High School (Part 1 Plate 110) occupied my studio wall during the modelling stages of *Just wait for me* (2012-13), pinned next to photographs of the piggybacking street dancers from The Hub (Fig. 102) and the *Ephidrismos* groups of girls (c300BC, Fig. 32,33) all influencing the afore-mentioned 'inner image' that underpins the studio work.

#### **4.2.3 Exhibitions of works from the workshops.**

I exhibited outcomes from The Hub scoping workshops (2009, Part 1 Plates 100,101,112,113) at Birkenhead Park Visitor Centre in February 2012 (see poster Part 3, p.104). I included the small-scale sculpture that represented street furniture such as a fountain, a bench with a ramp for skating, a grotto-type structure that could be climbed inside and out, large slides, a movable ice-cream and games hut, giant soft bouncy cushions, camping area and wonky double swings. These objects were also shown and discussed with Jackie Smallwood and Friends of Central Park in order to ascertain if any of the ideas could be integrated into the overall design for the site. Whilst they do not find approval, the idea of some multifunctional seating for a 'sit-off area' is integrated into the overall landscaping of the site. Some keep fit equipment for young people is also installed in the adjacent playground at the same time as my sculpture is installed.

Around the launch of *Just wait for me* (2012-13), I arranged an exhibition of the young people's small yellow statues in Central Park's Cricket Pavilion. Jackie Smallwood comments: "It was good that it was so timely really, 'cause it happened in coincidence really, that Brigitte had already started involving young people in the area and we'd just started looking at the site so it all sort of slotted into place ... it



was great ...so the timing of it was really good, and also the funding as well; 'cause that doesn't always work out well does it? Even though Brigitte had applied for the funding already sometimes that lead in process is too long ... it was all really funny the way it all just slotted into place and that was great; it's not often that happens!"<sup>43</sup>

#### **4.3 *Just wait for me* (2012-13), interpretation.**

Chapter 1 reflected upon the making and fabrication of *Just wait for me* (2012-13) and site research, logistics and workshops have been discussed above. This next section is dedicated to the interpretation of the sculpture as an installed piece of permanent public art. An evaluation of its impact and contribution to knowledge as original artwork will be discussed in the Conclusion.

Title            *Just wait for me* (Part 1 Plates 120-130)

Date            2012-13



Media            Piggybackers cast aluminium and paint

                    Seated girl cast stone and paint

Dimensions    Piggybackers 190cm high on 60cm plinth

                    Seated girl 80cm high on 60cm plinth

Location        Central Park, Liscard, Wallasey, CH44 0AB

##### **4.3.1 The approach.**

Walking or driving along Liscard Road, no matter the season, one can catch sight of the orange top and blue trousers of the tall piggybacking figure from about 150m away. Adjacent to the statues is a small car park that is heavily used by dog walkers. Between this and the actual footprint of the sculpture is a knee-high wooden barrier. Moving closer, the statues are all raised off the ground on 60cm high circular plinths. Whilst Central Park has many entrances, the majority of users approach from this northern entrance and see the back of the piggybacker's first before catching a glimpse of the seated girl. The glow of the orange and blue dominates first impressions. The bulk of the piggybacking figure is slightly larger than life-size towers above the scene and viewer. The lower statue of the carrier clasps his hands very tightly into the roughly-modelled trousers of the figure above, the carried. The carried finds some temporary rest on the waist height of the carrier who is bent forward slightly to bear the weight. Both figures are elongated. Their legs and arms appear longer in relation to the size of their hands, feet and head. The perception of this elongation is heightened by the parallel stance of the legs of the carrier in his tightly fitting skinny jeans. The carrier is not moving forward but standing still. He is only very slightly bent forward and seemingly capable of keeping his balance. He is not struggling under the weight of the carried and appears to be coping effortlessly.

This painless balance demonstrates a kinship with the Ephidrismos groups of girls (c300BC, Fig. 32,33) and the photos and statuettes made in the workshops (Part 1 Plates 102-119). The carrier appears stable and assured. He has a firm grip and his large feet are flat on the ground. This creates a stark contrast to the carried. In his zingy orange hood, the carried appears in a more precarious position. Seen from the back and the side, the carried appears froglike, caught in mid air and about to leap off into a void. Looking closer, we realise that he is only holding on with one hand, the other being clasped to his own elbow. Both of his arms create a u-lock around the chest of his carrier, like a collar or headlock. The dangling downward thrust of his legs accentuate the sense of him being the more precarious, at once arrested between slipping down and leaping forward.

For those approaching the scene from the south, from behind the seated

girl, the two piggybackers seem inseparable. Their heads are literally stuck together and the legs of one brackets and frames the other and arms pin bodies back. On closer inspection, one of the pale gaunt faces is in the perma-shadow of an oversized hood and the other in its half shadow. The activity that initially appears like a straightforward piggyback becomes slightly more ambivalent. The faces look very similar and it is not so clear any more whether the two are embodying two adolescent boys or showing one in two different states or fantasies. The work asks whether one is the externalised soul of the other or the play-acting, the bravado face of the other, a proposition I shall return to in the Conclusion.

#### **4.3.2 The piggybackers.**

The two ashen faces leave an uncomfortable trace on the viewer's retina. Are these clowns or youths belonging to a sub-culture that is masked? Are they from a different tribe, with significant dress as discussed in 3.1.2? In this piggyback group, dress again signals difference, especially the hooded baggy jackets. The modelled exaggerations and their ashen faces are undeniably grotesque and slightly 'not quite right.' They are alien and strange or, as one local comments at the unveiling, they are *gothic horrors*. The dark shadows cast by the hoods on both faces support this drama of unfolding uncertainty. The hood is an exaggerated form. From the side as mentioned before it resembles the gaping mouth of a frog and from the front it becomes a cave or shawl into which to retreat, like *Boy with knife* (2016, Part 1 Plates 97, 98). The atmospheric interplay of light on the piggyback statue reaches a climax of darkness and brightness in the hooded and collared faces and heads, in turn enhancing the sense of uncertainty in regards to its identity/identities.

#### **4.3.3 The seated girl.**

Opposite the piggybackers at a distance of about 10m sits the figure of an adolescent girl. Her hair is tied back in a knot and is of the same orange glow as the hood of the upper figure. Her turtleneck jumper, pulled over her drawn-in legs, is of the same colour as the trousers of the carrier. Her arms are locked around her knees. Surface colour and structure clearly indicate that this third figure is part of

the ensemble; she belongs to the same group or tribe as the piggybackers, yet she is apart from them. The dangling exuberance of the piggybackers is countered by her posture that is quite literally withdrawn. She is sitting in a compact mode and her body is hidden under the oversized jumper. Her head is raised and gaze directed towards the piggybacking boys. She is sitting there, watching from a distance. She is *waiting*. Within this group of three statues, the seated girl takes on the role of the spectator. She watches the spectacle of the piggyback, perhaps eyeing up which boy is the more suitable or perhaps just waiting to see what will happen next. This silent dialogue created between the three figures enhances the perception of autonomy amongst them.

#### **4.4 Celebrating waiting.**

Together with the slightly exaggerated colours and hoods it is the autonomy of the figures that triggers memories of the 'wild days' of Wallasey School of Art. The work permanently fixes into stone and aluminium the type of activity conveyed to me by the young people in The Hub. An interpretation sign, (Part 3 p.103) in the vicinity of the sculpture explains the site-specific context of the work. The joyful 'just for fun' banter I experience in all the workshops and the bravado expressed in the young peoples' statuettes is framed and sometimes overshadowed by other voices that talk about the pain of being dumped, being scared, not being accepted, just hanging out, just messing about and being with mates who are most likely engaged in doing something stupid or attempting to figure out what being a couple means. It is this hidden uncertainty in the boisterous interaction between young people, initially observed in the workshops, that is portrayed in the work.

The shadowiness of the ashen faces, the uncertainty of the shape-shifting leaping and carried figure contrasts with the firmness of the carrier and the isolated reserve of the girl. Together, it embodies the pleasure and pain of *waiting*. Over time, one can speculate further that the carrier is waiting for the carried to leap towards the girl, or for the extrovert other to slide deeper back inside his hood and darkness. Whether one is merely a projection of one's imagined other, or we are observing two genuine friends, remains open. Irrespective, what happens next is not yet embodied



future. It remains speculative and uncertain. Engaged in the activity of just waiting, these statues occupy the site and function as placeholders. They claim the space. As an autonomous arrangement of sculpture depicting adolescents engaged in some kind of banter, they are provocative in mirroring youth without context, suspended in mid-air and waiting. They are hanging about and attending to each other but without status, responsibility or the sheltered framing of family, ideology or state education. Giroux notes: “Not surprisingly, youth as a symbol of long-term commitment are now viewed as liability rather than an asset.”<sup>44</sup>

Left to their own devices the statues interact with each other forever, or at least for the next twenty years, within that circular engagement between the boisterous piggyback duo and the waiting, silently smiling and shyly hiding girl. The dynamic created by the trio is unsettlingly between playful banter and mischief. Is the carried grinning and messing about on this very land that once housed an art school full of young people experimenting? Does he embody, in his suspended leap, the metaphorical space of a future that belongs to them all? As viewers, we may be tempted to sit down on the new adjacent pebble seats provided by Wirral Council, but we are not really part of this perpetual and slightly shifty waiting game.

As with *Waiting* (2009, Part 1 Plates 25-30), the viewer remains a bystander and his/her relationship to the trio may be filled with the same level of curiosity and suspicion previously articulated in relation to the use of the former Liscard Hall as Wallasey School of Art that was full of the rebels who did things differently and claimed for themselves a freedom of expression under the watchful eyes of endless rows of Victorian terraces. As their author and creator, their bringer to life, I consider that these three figures have each other. They do not need more. *Just wait for me* (2012-13) embodies a state of being *in the activity* of waiting as a waiting for each other and the ‘next move’/the future. The sculpture celebrates this activity of waiting as joyous and uncertain activity. Central Park did not get Liscard Hall back, but it did get an artwork on the same spot that looks to the future while connecting with the past.

## Endnotes

- 1 Hauser, A., *The Social History of Art, Vol I.*, 1951, New York: Vintage Books, p100
- 2 Lippard, L., *The Lure of the Local: Senses of Place in a Multicentered Society*, 1997, New York: The New Press, p264
- 3 Cahill, H., *Art for the Millions, Essays from the 1930s by Artists and Administrators of the WPA Federal Art Project*, edited by Francis V. O'Connor, 1973, New York Graphic Society Ltd, Greenwich, Connecticut
- 4 Kwon, M., *One Place after Another: Site-Specific Art and Locational Identity*, 2004, MIT Press, Massachusetts, p57
- 5 *ibid*, p60
- 6 *ibid*, p124
- 7 Though Ahearn was local to the South Bronx, the set of figurative sculpture celebrating 'everyday people' of the neighbourhood was misunderstood by users of the park, and the artist took the work down after only four days. Kwon also cites artist Renee Green who was 'curatorially matched' to work with an African American organization in Chicago based on the presumption that her heritage would facilitate a direct point of identification in the creating of art. The artist refused to partake in the project.
- 8 Cahill, p43
- 9 Miles, M., *Art for Public Places: Critical Essays*, 1989, Winchester School of Art Press, p8
- 10 Miles, p4
- 11 Harding, D., *Decadent: Public Art - Contentious Term and Contested Practice*, 1997, The Glasgow School of Art, p14
- 12 *ibid*, p16
- 13 Bishop, C., *Artificial Hells: Participatory Art and the Politics of Spectatorship*, 2012, Verso Books, p283
- 14 *ibid*, p195
- 15 van Heeswijk, J., *Interview with Jeanne van Heeswijk*, online, available at: <https://tinyurl.com/yaydjxx8> [accessed 29.6.2018]
- 16 van Heeswijk, J. and B. Jurgensen, *HOMEBAKED: A perfect recipe*, online, available at <https://tinyurl.com/ycc2mb9f> [accessed 29.6.2018]
- 17 van Heeswijk, J., *Interview with Jeanne van Heeswijk*, online, available at: <https://tinyurl.com/yaydjxx8> [accessed 29.6.2018]
- 18 Edward Morris, E. and E. Roberts, *Public Sculpture of Cheshire and Merseyside (excluding Liverpool)*, Liverpool University Press, Liverpool, 2012; Cavanagh, T., *Public Sculpture of Liverpool*, Liverpool University Press, 1997; Liverpool Biennial public art archive available at: <https://tinyurl.com/nyv8yjs> [accessed 13.2.2017]

19 *ibid*, p11/12.

20 Curtis, P., *Patronage & practice: Sculpture on Merseyside*, 1989, Tate Liverpool, p158

21 *ibid*, p158

22 Central Park is surrounded by two the neighbouring wards Liscard and Seacombe. Densely populated with social housing and Victorian two-up two-downs, the total population of 16-64 year olds in 2001 was 8,900. Recent statistics show above-national levels of people claiming out of work benefit and high levels young people out of work. The Young People NEET (not in training, employment or education) figure in 2009 for Liscard was 13.3%, available at: <https://tinyurl.com/kzwhxj5> [accessed 13.2.2017]

23 The name of the Art school varied through out its existence at Liscard Hall. Referred to as Wallasey School of Art or The School of Art, Wallasey, local historians refer to it as Liscard Science & Art College which closed in 1982 at this particular site, moving to Withens Lane (Liscard) and subsequently to Wirral Met Campus, source: <https://tinyurl.com/lzkfy22> [accessed 13.2.2017]

24 Richards and Macdonald became British War Artist during the Second World War, Jardine gained some notoriety as an English surrealist painter and Moore is widely regarded as one of the leading British post-War photographers.

25 Chris Huston, guitarist with Merseybeat band The Undertakers, studied there between 1958-1962. After moving to the USA, Huston engineered and produced over eighty gold and platinum albums in his career, including working with The Who, Led Zeppelin, Van Morrison and James Brown. Other artists and musicians who studied at the Wallasey School of Art included Rico Bell of noted Leeds band The Mekons, Liz Nicol, Associate Professor (Senior Lecturer) in Photography at University of Plymouth, illustrator Charles Batchelor who worked for Punch and Andrew McCluskey of the band *Orchestral Manoeuvres in the Dark*.

26 *Blaze rips through Hall*, 2008, Wirral Globe, online, available at: <https://tinyurl.com/k7wzcf7> [accessed 13.2.2017].

27 Kester, G., *Conversation Pieces: Community and Communication in Modern Art*, 2013, University of California Press, p84

28 Bourriaud, N., *Relational Aesthetics*, 1998, Les Presse Du Reel, p85

29 Hirschhorn, T., *The Gramsci Monument, like all monuments, is made for eternity*, 2017, online, available at: <https://tinyurl.com/y749jpxj> [accessed 29.6.2018]

30 *ibid*

31 Fagan, C. James, "*Teamwork and co-creation lie at the heart*": *Dogsy Ma Bone Musical Launches Liverpool Biennial's Inaugural Touring Programme*, 2017, online, available at: <https://tinyurl.com/ycvewk8u> [accessed 29.6.2018]

32 Hirschhorn, T., *The Gramsci Monument, like all monuments, is made for eternity*, 2017, online,

available at: <https://tinyurl.com/y749jpxj> [accessed 29.6.2018]

33 Kester, 2004, p110

34 Bishop, p284

35 Lucas, K., *Celebrations for Breaking Routine*, 2003, online, available at: <https://tinyurl.com/ybz9hkhn> [accessed 29.6.2018]

36 Newell-Hanson, A., *no one captures the awkwardness and possibility of youth like rineke dijkstra*, 2017, online, available at: <https://tinyurl.com/ycybrfo9> [accessed 29.6.2018]

37 Horlock, N., *Just Wait for Me, Evaluation Report*, 2013, Part 3 p41-73

38 Woodson, S., *Performing Youth: Youth Agency and the Production of Knowledge in Community-Based Theatre*, 2007, in A.L. Best (ed.), *Representing Youth: Methodological Issues in Critical Youth Studies*, 2007, New York: University Press, p296

39 Horlock, p18

40 Horlock, p8

41 ibid

42 Woodson, p294

43 ibid, p19

44 Giroux, H., *Youth in a suspect society. Democracy or Disposability?* 2009/2010, Palgrave Macmillan, NY, page unknown.





## Conclusion.

The Conclusion begins by reflecting on the single, double and triple figure(s) in relation to Walter Benjamin's idea of a sculpture's 'spiritual essence'<sup>1</sup> and the theories of psychoanalyst Otto Rank<sup>2</sup> and anthropologist Michael Taussig<sup>3</sup> on the nature of representation as expressed through the double. Specifically, through my research, the double is understood as a form of three-dimensional reflection that enhances the sculptural representation of youth as uncertain; the double embodies the confrontation between self and its own image in time and space.

The next section considers my contributions to socially engaged, 'local' and site-specific public art in relation to methods that have been employed by artists and artist groups discussed in the previous chapter. This addresses a gap in knowledge that exists around a hybrid method that acknowledges 'the local' but also regards distance and difference (eg age, educational background or nationality) as positive factors. I also introduce the term *user-expert* in relation to socially engaged art practice.

The final section focuses on the public statuary of youth on Merseyside and the unique contribution the iconography of *Just wait for me* (2012-13) makes to this. My sculpture represents youth in states of ambiguity: vulnerability and strength; awkwardness and elegance; uncertainty and bravado. These states are rehearsals of relationships with the world, the self and each other and as such they occupy and claim a public space as 'holders of the future', requiring attention and compassion in the public domain.

These three concepts – the use of the double, the local/*user-expert* relation within socially-engaged practice and the new statuary of youth that recognises key motifs – form the contribution to knowledge of this submission.

## **The use of the double (one, two).**

As discussed in Chapter 1, throughout my research the conditions of the studio impact upon the size and numbers of works produced. The singular figure is foregrounded in the early stages of the research before the Bootle studio facilitates the possibility of working on two figures simultaneously. The singular and double figure(s) feature across all three motifs in Chapter 2. This conclusion further articulates the significance of this shift within my own practice towards the use of the double figure as a form of three-dimensional reflection that represents youth as uncertain, awkward and being in limbo.

### **One: the *I* in *the world*.**

In the following section I use the terms *I* and *the world* to describe the relationship between the sculpture as an individual subject (*I*) and its surroundings (*the world*). The surroundings in questions are beyond the merely physical and encapsulate attitude. To provide an example, a monumental statue of the ageing Queen Victoria embodies an attitude of matriarchal control whilst a younger version of the same Queen on horseback embodies an attitude of adventure and freedom. In shifting from writing about sculpture as an object (*it*) to writing about a sculpture as a subject (*I*), I follow the theory that images have their own life and will. In referring to his *Picture Theory* publication, Professor of English and Art History W. J. T. Mitchell notes “I felt like there was something more that I hadn’t really come to terms with and that was the character of the image or the picture as something that seems to have a life of its own. I began to notice that it was almost impossible for people to talk about pictures without attributing some kind of animism to them or some vitality.”<sup>4</sup>

Applying this phenomenon to my sculpture, this switch from *it* to *I* acknowledges the idea that the artworks have desires and want you to look at them. We are observing the *I* within its own surrounds but must simultaneously consider its attitude and state of being. Sculpture such as *Boy with mouse* (2009, Part 1 Plates 54-58), *Boy with parasol* (2009, Part 1 Plates 59-63) and *Monument for Damian* (2008, Part 1, Plates 66-72) represent a state of play of the pre-adolescent boy engrossed in his own world and caring for that same world; the figure is not *it* but an *I* that is displaying compassion. By contrast, *Girl with fire* (2011, Part 1 Plates 64,65) represents

a moment of increased independence of the adolescent girl, signified as the first flaring of the sexual effects of her youthful athletic body. The attributes of the burning flame and ash are temporary as if the world of tangible objects has lost its appeal and has been replaced by a world of ephemeral and less controllable elements; fire and its metaphoric use with the sexual awakening of the girl.

The singular figure *Boy with knife* (2016, Part 1 Plates 97, 98) embodies doubt and uncertainty as to the worth of the *I* in relation to the world. This figure asks if the *I* is worth fighting for or if it is even worth remaining in the world; the sculpture represents the moment of adolescence during which the *I* feels at odds with its surroundings, as if railing against one's mortality. Now, *the world* is not a place of play and sexual awakening but of potential violence and death. The singular figure and its attributes used in the representation of pre-adolescents and adolescents signifies not only the motifs of rehearsal, inwardness and vulnerability but also articulates the attitudes and different power relationships the *I* of the singular figure has with its surroundings, ranging from taking care to potentially fatal violence.

## **Two: the *I* and the representation of the *I*.**

The yellow wax statuettes created by workshop participants (Part 1 Plates 99-119), based on a likeness of the same participants' photographs of themselves, may also be viewed as a form of double. In 1.4 and 1.5 I discussed making as a 'call and response' process and the making of the same figure again by the same person, rather than a technician, plays a unique role in the context of this research in regard to my studio practice and for the actual meaning and significance of the sculpture. The first figure comes into existence through the aforementioned dynamic between 'inner image' and 'outer taking of shape' (1.4). The second figure seeks to mimic the first without mechanical reproduction. Within this process, the making of the second figure is an active reflection of the first, since it is within the dialogue with the first that the second is created. The second one is created in the image of the first one; the second one imitates the first.<sup>5</sup>

The making process of the second one is in itself a reflection, a reflective practice, on the initial sculptural representation akin to a self-scrutinising look in the mirror or photograph. It is the confrontation of the self represented in the first figure



with its own image in time and space. The reflection of the first becomes three-dimensional reality too, as if the shadow of the first gains materiality. The workshop participants modelled their yellow wax statuettes in the likeness of the photographic image of themselves (Part 3 Plates 102,103). The statuette is a smaller version of its maker as seen through the camera and is thus a carrier of his/her expression of sadness or happiness. The young participants also viewed the other, the statuette, as a three-dimensional representation of the self as captured in their photographs. Shaping the yellow wax into statuettes they strive to get the expressions 'right', allowing them to combine the visual clues from the photographs with their own embodied experience. The resulting statuettes are not doubles of the photographs, but of the embodied experience of which the photograph serves as a reminder. The use of the non-mechanically reproduced double in *Waiting* (2009, Part 1 Plates 25-30), *Sleeping Beauty* (2015, Part 1 Plates 83-90), *If only* (2016, Part 1 Plates 91-96), *Dunno* (2016, Part 1 Plates 73-79) and *Just wait for me* (2012-13) is informed by and situated in the context of the dialectical juxtaposition of the allegorical figures of *Ecclesia* and *Synagoge* (c1230, Fig. 86), the figurative rendering of the *Parable of the wise and foolish virgins* (1250, Fig. 85) and the doubling of the *I* in *Narcisse* (1868, Fig, 82) and *Girl Looking into Mirror* (1970, Fig. 81).

Taussig refers to this form of double as having point-for-point correspondence of body part to body part without it being a faithful copy.<sup>6</sup> I note during the workshops how much effort and time the participants invested into the malleable material until it starts to 'speak back' to them. It seems as if the yellow wax becomes "spiritualized to the point that nature 'speaks back' to humans, every material entity paired with an occasionally visible spirit double - a mimetic double! - of itself."<sup>7</sup> At that moment of creation, each of the yellow statuettes becomes an externalised three-dimensional double of its maker, incorporating as it does the quintessential features.<sup>8</sup> The young people do not see themselves in the mirror, but create *the other* that reflects the self. In so doing I am proposing that they create a double, that like the image in the mirror or the shadow on the floor derives from what Rank terms "the unconscious impulse to lend imagery to a universal human problem - that of the relation of the self to the self."<sup>9</sup>

## The significance of the double in the representation of youth.

From the proposition that the double can represent the spirit or soul, or as Taussig suggests: “the protean self with multiple images (read ‘souls’) of itself,”<sup>10</sup> what is the significance of the double figure in the submitted representation of youth in the twenty-first century in conjunction with the motifs of readiness, self-absorption and vulnerability? The doubles in *Waiting* (2009, Part 1 Plates 25-30), *If only* (2016, Part 1 Plates 91-96), *Sleeping Beauty* (2015, Part 1 Plates 83-90), *Dunno* (2016, Part 1 Plates 73-79) and as part of the *Just wait for me* (2012-13) ensemble speak of the same figure in two different moments and in so doing give new forms to the idea of ‘two’ representing the self as being and becoming. The submitted doubles appear self-sufficient. The figure and its three-dimensional reflection are present. It is as if both the self, the body of the first figure, and its soul, the second figure, are there to be seen. In other words, the figure and the representation of the figure are simultaneously there. As noted in 3.2.2, the fact that there are two almost identical figures sitting on the table in *Waiting* (2009, Part 1 Plates 25-30) conveys a factuality of otherness that keeps the viewer at an unbridgeable distance. It is as if the body of one seated figure but also its imagined future, its soul, shadow or image of itself, is present in the form of the second seated figure.

In *Sleeping Beauty* (2015, Part 1 Plates 83-90), the figures lie back to back (3.3.2). The double is the mirror figure of the first. Again, the body of the first figure is represented by a second one, enhancing the sense of completeness of the withdrawn body, which takes with it a withdrawn soul, the visualisation of a complete absence whilst asleep. The figures of *If only* (2016, Part 1 Plates 91-96) are lying in opposite directions to each other, torso next to torso, arms and hands nearly touching. This arrangement disrupts any viewing from a fixed vantage point, as top and bottom are rotated. The rotation of the first and its double rhetorically enhances the sense of objectified vulnerability. Similar to a rotating tabletop, whichever way one looks, the body of the first figure and its double appear over exposed and vulnerable. In *Dunno* (2016, Part 1 Plates 73-79), the figures stand side by side and face the same direction. Their eyes are directed into some unidentifiable distance, a spatial distance, but also a distance in regard to time such as the not yet known future. Artist Mary Maclean writes of them that “the sculpture generated a strong sense of the human glance - the double bind of looking and being looked at”<sup>11</sup> suggesting that

the doubling in *Dunno* (2016, Part 1 Plates 73-79) also articulates the unease of the viewer being looked at, and the figure(s) becoming subjects, rather than objects. Or as Ludwig Wittgenstein observes: “We do not see the human eye as a receiver, it appears not to let anything in, but to send something out. The ear receives, the eye looks. It casts glances, it flashes, radiates, gleams. One can terrify with ones eyes, not with ones ear or nose. When you see the eye you see something going out from it. You see the look in the eye.”<sup>12</sup>

In the vis-à-vis of the two slightly different figures in *Dunno* (2016, Part 1 Plates 73-79), the ‘looking at’ is met with eyes that are looking out and into the beyond as if to suggest that the two figures could do without us, the viewer. The figures’ athletic stature, referencing the frontality of the Koroï and their nimble footedness, demonstrates their readiness for what lies ahead. The double functions as a guardian of the treasure, the treasure of the embodied life of the first one, which, in anticipation of what may lie ahead, remains as a guarantor, or stand-in.<sup>13</sup> Facing the unknown, it seems as if one of the two might make the next move, whilst the other might stay behind. The notion of the sculpture as a stand-in or placeholder becomes prevalent, as a photograph of a deceased family member may function as a stand-in for the permanent absence.

The *I* of the pre-adolescent boys and girls is depicted in relationship to *the world*. The *I* and its double visualises the relationship the adolescent boys and girls have with themselves. These relationships are shown as provocative, fragile, vulnerable, uncertain and risky. As doubles, they emit being and becoming and function as stand-ins and symbolic carriers of the future. These figures and their doubles are not only complete, a completeness of sexual virility and fertility, they are also unattainable in their completeness. With eyes closed, blindfolded, covered or locked into a far away gaze, they are by themselves and out of the viewer’s reach.

The double within *Just wait for me* (2012-13) is that of the carried and the carrier. It lends itself less to the mirrored soul than that of the double as a louder, more virile, extra deviant other, enhanced by the zinging colours, oversized hood and frog-like clinging. The double becomes a more independent and unruly other. In this case the double, carried on the back of the carrier, can be understood as what Rank terms “a personification of one’s own evil impulses.”<sup>14</sup> In *Just wait for*

*me* (2012-13) the double may work “at cross-purposes with its prototype; and, as a rule, the catastrophe occurs in the relationship with a woman.”<sup>15</sup> In the piggyback formation, the carried figure embodies the more forthright, virile and risk-taking self of the carrier. The double takes on the role of the self that dares, in contrast to the one that is steadfast.

All these doubles acknowledge the unique status of *Youth (Kritios or Kritian Boy)* (c480BC, Fig. 52), whose *singular* representation of the magnificent beauty of the youthful, athletic and virile body is synonymous with *The Idea* of the divine spirit. In him, the specific and the ideal of the beautiful and good overlap; he embodies vulnerability and strength in *one* form. The almost identical girls and boys in many of my works are also attempts at creating *singular* three-dimensional images of youth in full acknowledgement that an overlap of the beautiful and the good is unattainable. As artworks they are invested with tender empathy showing stubbornness, vulnerability and uncertainty as characteristics of youth in the twenty-first century. It is an understanding and realisation of these factors drawn together that enables my submitted sculpture to add to the existing representation of youth discussed in Chapter 2.

### **Difference as a force for good.**

The unique contribution the work has made to the local context of public statuary of youth on Merseyside centres on the participatory and site-specific underpinning of the work in the form of the three dimensional image of three young people waiting. Adding to the detailed analysis of the site, participation and the interpretation of the sculpture in Chapter 4 I will concentrate on the significance of time, local knowledge and participation. The processes underpinning *Just wait for me* (2012-13) and the work itself represent a hybrid method driven by local knowledge that uses difference as an empowering force. My communication with people and material comes from this position that accepts difference in relation to space and time as a positive. These differences include space usage (ie Central Park as multi-functional), the distance in age between myself and the young people I worked with, the distance between local and ‘foreign’ (myself as local but German-born) and the distance between the professional attributions and expectations (teachers, artists, student, young person, Friends of the Park, youth worker). There are also variations in time between brief



workshop encounters and the longer narrative around a public artwork on a former art school site. My position acknowledges these in-built differences as integral and positively empowering in regard to communication, the act of making and the three-dimensional image: namely the sculpture itself.

### **The user experience as a shared experience.**

Lippard speaks of public art as one that cares, challenges, involves and consults the audience *for whom* or *with whom* it is made. *Just wait for me* (2012-13) challenges the terminology of 'audience', replacing it with the term *user*. This shift from audience to user allows for the inclusion of the researcher and artist in the specific space and time, but also for the inclusion of all others across time, both past and present, as *user-experts* in the process. All those involved in the processes underpinning *Just wait for me* (2012-13) did so as user-experts and as such it is not surprising that the young people in the Youth Hub were as concerned with what was going to happen to the site as their outreach Youth workers, the volunteers who run the community café or those representing the Friends of Central Park. Whilst their professional class, age and economic status varied hugely, my approach was driven by the axiom that all participants, including myself were experts in their own user experience, concerns and feelings, as expressed verbally and non-verbally.

Furthermore, all of us had one thing in common, namely the experience of the destruction of Liscard Hall and a sense that this symbolically marked the neglect of local amenities within a wider decline of a marginal inner-city area in the north of England. Vicinity and local knowledge are of paramount significance in regard to the timing and approach.

As such this process of engagement and resulting artwork differs significantly from that of van Heeswijk, Superflex and Assemble. These artists were approached by curators and specifically brought into Merseyside sites and situations as potential 'problem solvers' – within festival programmes - on the strength of their existing work in community empowerment. Yet these artists' deep understanding of specific local contexts can only be achieved through agency (van Heeswijk had a local artist to show her around the area, Superflex collaborated with a Merseyside artist as project manager and Assemble worked with a large on-the-ground team.

My work proposes instead that within socially-engaged practice, there is a severe gap in knowledge of what happens when the artist *is* the agent; when the artist *is* both local *and* different; the artist is also the ‘problem-solver’ with acute and first-person knowledge of the specific site (gained only from, for example, ten years lived experience) and when this artist combines both a sensitive community/ socially-engaged practice *and* a studio practice. This may resemble a description of the early community artists, but as I have argued, we must take from those early experiments our commitment to genuine social activity and shared authorship, but add to them this new hybrid method for working in this instance with young people. To the important engagement processes, I bring a rigorous knowledge of the iconography of the sculptural portrayal of youth, a belief in the role of ‘permanent’ public statuary on Merseyside *and* the transformative power of sculpture.

My contribution to knowledge is thus *Just wait for me* (2012-13) but also the figurative sculptures that inform the work as documented in Part 1 - the singles and double figures - the workshops with the young people, the technical experiments in the varying studios, the evidential records of engagement and the analysis of the key motifs within the sculptural portrayal of youth.

Horlock’s evaluation report states that timing of the project was fortuitous in as far as I as the artist was able to articulate the potential for work at a time when the underdeveloped site remained an unresolved topic between the general park users, the Friends of Central Park, and the Council.<sup>16</sup> A general improvement plan of Central Park had been in discussion at the time, but was not publically available. It took an artist living within five minutes of the site, rather than a commissioning body or curatorial team, to identify the potential for an intervention and respond to this gap by taking the initiative to approach the local Youth Hub. This timely artist-led ‘bottom-up’ approach gave focus to the hitherto vaguely expressed ambition to ‘do something for improving the park for young people’ and paved the way for overall project support, creation and maintenance. As mentioned, the artist here *is* the instigator, researcher, engager *and* producer. It was neither the Central Park community, the local council nor an art institution that identified the site and its potential. Unlike the other projects discussed in Chapter 4, *Just wait for me* (2012-13) was entirely driven and organised by the artist while living local to the site and all contacts, meetings, workshops, fundraising including seeking financial support

from the local council, were undertaken by the researcher/artist.

### **Expert amongst experts.**

In contrast to Kester's dialogical model that seeks to re-define the role of the artist as listener and facilitator rather than single authoritative voice, all stages of preparation and development of *Just wait for me* (2012-13), from original scoping exercises to structured class room based workshops, commenced with the artist as authoritative expert voice. This expert voice is not only attributed and expected, but also required when brokering access to young people in formal and informal settings and when approaching council representatives. Gatekeepers from all institutions expect expert performance. The ACE report acknowledges the high quality of communication, clarity of project outline and exceptional degree of workshop delivery based on the professional experience of the artist as international artist and university lecturer.<sup>17</sup>

Commissioned to create a piece of public sculpture for the City of Bremen, artist Jochen Gerz created *Bremer Befragung* (1990-1995). Citizens of Bremen were surveyed as to what the topic of the work should be, whether their ideas could be realised and if they would wish to participate in the work. The resulting work comprised the publication of a book with 268 answers from 268 Bremer citizens, with their names also appearing on the site where the commission was intended to have been located. Gerz's approach highlighted that if you ask 50,000 people (the amount of questionnaires originally distributed) you get 268 different answers. For Gerz, the work is an immaterial sculpture that exists in the actual answers of those who responded and the public discussions which surrounded the project. An additional outcome of the *Bremer Befragung* is thus the transparency of the impossibility of creating *one* public object or sculpture that represents the spirit of the people of Bremen. *Bremer Befragung* cares for the audience: challenging, involving and consulting the same citizens *for* whom the work was commissioned. What we 'see' is an immaterial sculpture that exists only in writing, imagination, storytelling, public discussions, a published book and a nameplate on the Bürgermeister Smidt-Brücke. By changing the *for* into a *with whom*, Gerz attributes the expert status upon those who responded; invited by the city as an expert, he calls upon the imagination of citizens and transforms them into experts.

The development of the Central Park sculpture utilise a similar approach, but switches from spoken and written language dependency to a visual and sculptural language dependency. It too commences the communicative processes with the overarching concept that the young people are experts in knowing their own feelings and experiences of the park. Clay, wax, movement, performance and photography were used as equivalents to questionnaires, enabling young people to become informants of their experiences in a less intellectually and more physically-driven manner. The workshops facilitated embodied imagination that was based on the observation of the self as performed self. And as one participant reflected, “(We) made wax sculpture .... looked at friendship; we were all in one group, our (theme) was friendship and others had, like sadness... we were talking about friends, taking pictures, giving each other piggy backs.”<sup>18</sup>

The workshops invited imagination within a given structure, centred around a specific geographic site (and the past, present and future usage of that site) of which they had lived experiences. Furthermore, the unknown workshop material of yellow wax was new and exciting for young people who found the workshop and studio visit inspiring, since the “opportunity to work with sculpture was a rare and exciting one.”<sup>19</sup>

The focus on a specific space and the three dimensional representation of the performed self in space facilitated active participation in the meaning-making process in regard to past and future experiences of the site.<sup>20</sup> Although not one particular yellow statuette provided the actual design for *Just wait for me* (2012-13), the workshops offered insights into the manner in which young people performed with each other, moved in space and translated their experiences into form. Doing this with full knowledge of the site as a place for meeting, ‘hanging around’ and ‘having a sit off’, the young people represented themselves in the socio-political sense of the *Vertretung* (*speaking for*) and as *Darstellung* (*standing in for*).

While the young people of Merseyside appear as actors, makers or sitters in the work of Chetwynd, Lucas and Dijkstra, *Just wait for me* (2012-13) does not feature the specific young people involved. Instead, their participation contributes to the representational image, the iconography of the sculpture that functions as a permanent stand-in for a state of being that is fundamentally in flux.



*Just wait for me* (2012-13) was created with the knowledge of the yellow statuettes and refers back to Lippard's assertion of our need to care, challenge, involve and consult the 'audience' which I reframed as users. Rooted in the local, with specific user experience shared generously, the workshops and other communicative processes that underpinned the development and realisation of *Just wait for me* (2012-13) affected the decision making processes, including those taken by the institutional representatives, such as Jackie Smallwood, ACE, teachers and Youth workers. Public art and urban design have often been "characterized by imbalanced power relations in the production of symbolic and material forms, ownership of tools, and control of the rules"<sup>21</sup> since decisions around the artistic transformation of space were traditionally taken by 'experts' such as town planners, commissioners or curators. As discussed in Chapter 4, over the past two decades the claim to equality within participatory 'new genre public sculpture' has become increasingly undermined by curated and institutionalised matching processes that shoehorn participants' contributions into aesthetic concepts of specific artists and their aesthetic concepts into institutional aims. *Just wait for me* (2012-13) demonstrates ways in which diverse local expert knowledge can be catalysed and moved to hitherto unimaginable realisations by interference generated by the users.

Horlock's detailed evaluation collates evidence of the emancipatory impact of *Just wait for me* (2012-13). For example, she highlights how a particular young person's career choice changed after the workshop participation and that in general young people gained confidence<sup>22</sup> as they encountered new materials and processes and for the first time worked in sculpture at a high professional level.<sup>23</sup> The communication processes raised the overall expectations and the sculpture itself helped to transform negative attitudes of regular park users into positive, supportive and enthusiastic attitudes,<sup>24</sup> improving the park area<sup>25</sup> and being regarded as 'fabulous', 'cool' and beautiful.<sup>26</sup> Horlock captures the response of a passerby:

I think people can be quite negative a lot of the time but it's only when you start explaining things to them they think 'Oh, well, yeah, that is quite good' ... even myself, when I was on site one day I seen two elderly people coming toward me and I thought they were going to be really negative as they were saying 'Are you responsible for this?' sort of thing and I was like 'Oh, here we go ..', sort of thing and

I said 'Oh well the artist has been working with young people to do this and we've been landscaping the site' and she said 'Oh no, I think it's wonderful' and I said 'Well the artist'll be here later if you want to come 'cause they're doing the opening ...' and she said 'Oh no, I just wanted to tell someone how marvellous it is ...'<sup>27</sup>

In 2008, the destruction of Liscard Hall was for many, including myself and my adolescent children, a symbolic reminder of managed decline. With nothing happening after the Hall's rubble was removed, there remained a visual sign of neglect and a receding shared memory that, once upon a time, local young people painted, drew, danced, dressed up and experimented with materials and emotions. Living with this scarred site provided the original impulse for *Just wait for me* (2012-13). Beyond this *shared* user experience, the significance was the creation of a 'bottom up' hybrid method that combined participation and site with the production of a permanent and freely accessible three-dimensional image in a public setting. Within my approach, young people participated in the production of symbolic and material forms that replaced their experience and actual image of self as marginalised Central Park users into a representation that claimed and occupied centre stage in a loud and boisterous manner. Approaching six years on from installation, *Just wait for me* (2012-13) remains unscathed and cared for by the community that informed it and contributed to it. Those young people will now be young adults and, for one at least, now taking their own children to Central Park to see the sculpture.

***Just wait for me* (2012-13), a statue of youth as carrier of 'awkward presence and undetermined future' sited in Central Park, Wallasey.**

Having ascertained that the work emerges and thrives from a freedom of observing young people at moments when they are amongst each other and the history of the site as art school, the figures of *Just wait for me* (2012-13) have an unnerving quality, appearing brash and ever so slightly unruly. In conjunction with the information signage on the perimeter fence, documentation of which is included in Part 3 (p.103), the grouping takes on the role of a commemoration, a reminder of an art school's playfulness and spirit of rebellion and, unlike the formal restraint of Preston's *Monument to the World Boy Scout Jamboree* (1930-31, Fig. 89) at Arrow Park, *Just wait for me* (2012-13) commemorates adolescents in a state of restless active waiting, a waiting that is a waiting for each other and for the next turn.

*Just wait for me* (2012-13) publically represents youth through the medium of sculpture as awkward, restless and uncertain. Whilst all other sculpture of youth on Merseyside embody youth as carrier of the future empire or as carrier of a natural (as in closer to nature) state of mind, this new sculpture embodies youth as uncertain in regards to its future, as awkward, vulnerable and yet filled with bravado.

This uncertain awkwardness combined with bravado is held in a fragile balance due to the ambivalent identity of the piggybacking double and the on-looking third figure. The piggybacking double also alludes to the afore-mentioned notion of the doppelgänger, yet it is less certain whether the carried is the mischievous double of the carrier, or a different character. What is clearer to surmise, when surveying some of the photographic source material garnered from the workshops, is that the two young street dancers from The Hub in Wallasey (2011 Fig. 102) look superficially similar to each other, confirming the importance of clothing, gesture and friendship to notions of belonging. Supposing the carried *is* the outwardly more boisterous double (a projected *I*) of the carrier (a prototype *I*) or a slightly more extrovert friend (a separate *I*), *Just wait for me* (2012-13) introduces a third figure in the form of the seated girl who observes the males as they perform their double act. In this ensemble, a third figure is used in close proximity to the double to reference the motif of rehearsal and also to introduce different power relationships between the *I* of the singular figure and the performed or projected *I* of another figure. The adolescent boy(s) represented in the piggyback sculpture rehearses his effect on the girl through a form of playfight that demonstrates strength and wickedness. The girl becomes the spectator. The roles and status of the adolescent boy(s) and girl are interdependent on each other. The relationship between the *I* and *the world* is depicted here as a relationship between almost-equals at the exclusion of everything else. That is, a relationship that is defined in space as act of waiting for each other.

Suspended in the act of waiting the figures' silent but highly animated dialogue is so intense that they appear absolutely oblivious to anything outside of themselves. This again creates a relationship with the viewer that is informed by distance, whereby not even physical proximity to the actual pieces brings any greater closeness. On the contrary, the powerful sense of apartness is integral to the meaning of the work, akin to Artangel Trust's James Lingwood's description of Muñoz's sculpture, "Being amidst the work creates a powerful sense of apartness."<sup>28</sup>

My representations of youth embody otherness, an otherness that speaks of vulnerability, playfulness and uncertainty in the portrayal of adolescent boys and girls in the twenty-first century. Rather than marginalising young people already on the periphery of a large city, two (or three) of them re-emerge on a pedestal in all their awkward and overwhelming presence. *Just wait for me* (2012-13) celebrates the symbolic bravado that “connects the risky behaviour of daredevil stunts, pranks and nuances with the rites of virility, with proving one’s valour and claiming one’s own territory to assert presence.”<sup>29</sup> The zingy orange of the hood and hair, the exuberant posture of the piggyback double and their location in Central Park confirms that these figures visualise and express self-consciousness and vitality, an irresistible joy of being alive and filled with immeasurable strength and potency.

Whilst the economic decline of the area has not been noticeably halted, the sculpture remains unvandalised in their exuberant uncertain posturing. One local councillor commented, “the sculpture is an innovative piece of art that contrasts brilliantly with the war memorial”<sup>30</sup> and the “icing on the cake”<sup>31</sup> after years of waiting for some improvements to the park’s facilities.

As I argued in Chapter 4, a more managerial approach to site-specific and participatory art has grown significantly within the Biennial climate, particularly in Liverpool. These have led to some significant community participatory art works and on occasion left a permanent legacy in a differing form (eg the Homebaked business). I have also discussed those moments when inter/nationally-known artists have been greatly supported in working with young people of Merseyside on the creation of new artworks. In my research, I have found few examples of these collaborations that were *not* performance or digitally-based and shown in established museum and gallery settings.

While this may reflect wider tastes, I believe it also creates a gap in knowledge for more accessible (eg outdoor and public) and permanent (by this we could say at least twenty years) artworks that *also* advance our understanding of the actual creative mechanics of socially-engaged practice, materials, understanding of site, acceptance of difference as a positive and the crucial role the studio plays in everything.



The single most important contribution of this work is the iconography: the sculpture insists that youth as a state of messing about, waiting for each other and a not yet defined future, is worth celebrating through public statuary. In the face of increasing privatisation of public spaces, *Just wait for me* (2012-13) claws back that freedom of being in time, permanently claiming a former art school site to celebrate those perhaps branded as nuisances. The sculpture occupies public space as stand-ins, proclaiming the importance of such arenas as spaces in which young people have the freedom to express themselves. The sculpture provides encouragement that un/certainty, awkwardness and bravado are worth celebrating in public. No other permanent statue representing youth on Merseyside has dared to do that.

### Endnotes

1 Bullock, M. and Jennings, M., eds. *Walter Benjamin: Selected Writings, Part 1: 1913-1926*, 2004, Belknap Press, Cambridge Mass. and London, p141.

2 Rank, O., *The Double: A Psychoanalytic Study*, with introduction by Harry Tucker, 2009, University of North Carolina Press Enduring Editions,

3 Taussig, M., *Mimesis and Alterity: A Particular History of the Senses*, 1993, Routledge, UK

4 Liu, L., *On the Edge of Critical Thinking - An Interview with W. J. T. Mitchell*, 2005, online, available at: <https://tinyurl.com/mv5coop>, [accessed 10.4.2017].

5 The German word composites *nachmachen* and *nachahmen* combine the time prefix *nach* (after) with that of imitating through the process of making (*machen*) or action (*ahmen*).

6 Taussig, M., *Mimesis and Alterity: A Particular History of the Senses*, 1993, Routledge, UK, p52

7 *ibid* p97

8 See Part 1 Plates 99-119, in which billowing skirts and raised legs signify happiness and joy and arms clasped around legs drawn in signifies feeling down or alone

9 Rank, O., *The Double: A Psychoanalytic Study*, with introduction by Harry Tucker, 2009, University of North Carolina Press Enduring Editions, pXIV

10 Taussig, p97.

11 Personal email correspondence between Mary Maclean (RA) and Brigitte Jurack, 2016.

12 Anscombe, G. and von Wright, G., eds., *Ludwig Wittgenstein: ZETTEL*, 1967, University of California Press, p40.

13 Rank, p55.

14 *ibid* p40.

- 15 ibid p33.
- 16 Appendix p62.
- 17 ibid p49.
- 18 ibid p49.
- 19 ibid 49.
- 20 Iannelli, L. and Musarò, P. (eds), *Performative Citizenship: Public Art, Urban Design, and Political Participation*, 2017, Mimesis, p54.
- 21 ibid, p11.
- 22 Appendix p50
- 23 ibid, p56
- 24 ibid, pp51-53
- 25 ibid, 54
- 26 ibid, 52
- 27 ibid, 52
- 28 Lingwood, J., *Juan Munoz: Monologues & Dialogues*, 1996, Madrid, p16.
- 29 Schindler, N., *Guardians of Disorder: Rituals of Youthful culture at the dawn of the modern age*, 1997, in Levi, G. and Schmitt, J.C., eds. *History of Young People (ancient and medieval Rites of Passage)*, 1997, Belknap Press of Harvard University press, Cambridge Mass; London, p. 240-282.
- 30 Appendix p12.
- 31 ibid p63.

## Bibliography

- Anscombe, G. and von Wright, G., eds., *Ludwig Wittgenstein: ZETTEL*, 1967, University of California Press.
- Barrie, J.M., *Peter Pan, the Boy who wouldn't grow up*, ca 1904, Hodder & Stoughton, UK.
- Bauman, Z., *THE TWILIGHT OF THE SOCIAL: RESURGENT POLITICS IN AN AGE OF DISPOSABILITY*, 2012, online, available at: <https://tinyurl.com/k8tz2zg> [accessed: 9.04.2017].
- Belting, H., *An Anthropology of Images*, 2011 Princeton & Oxford, Princeton University Press, New Jersey.
- Benjamin, W., *Gesammelte Schriften II*, 1977, Tiedemann, R. and Schweppenhäuser, H., eds. Suhrkamp Verlag, Frankfurt/Main.
- Berger, J., *Permanent Red: Essays in Seeing, new edition 1979*, reprint 1981, Writers and Readers Publishing Cooperative.
- Best, A.L. (ed.), *Representing Youth: Methodological Issues in Critical Youth Studies*, New York: University Press, 2007).
- Bettelheim, B., *The Uses of Enchantment: The Meaning and Importance of Fairy Tales*, 1991, Penguin Books.
- Bishop, C., *Artificial Hells: Participatory Art and the Politics of Spectatorship*, 2012, Verso Books, p283
- Blom, I., *Media Animism: Rachel Harrison's Living Images in Art and Subjecthood, The Return of the Human Figure in Semicapitalism*, 2011, ed. I. Graw, D. Birnbaum, N. Hirsch, Sternberg Press, Berlin.
- Blunt, A., *Peter Peri*, 1936, The Spectator, online, available at: <https://tinyurl.com/kosadgx> [accessed 10.4.2017].
- Bober, P., and R. Rubinstein, *Renaissance artists and Antique Sculpture, a handbook of sources*, 2011, Harvey Miller Publishers, Oxford University Press.
- Boucher, B., *Italian Baroque Sculpture*, 1998, Thames & Hudson, London.
- Bourriaud, N., *Relational Aesthetics*, 1998, Les Presse Du Reel, p85
- Boyce, F.C., *Millions*, 2004, MacMillan, London.
- Bullock, M. and Jennings, M., eds. *Walter Benjamin: Selected Writings, Part 1: 1913-1926*, 2004, Belknap Press, Cambridge Mass. and London.
- Butler, S., *The Elephant in the Moon*, poem, c1670.
- Cahill, H., *Art for the Millions, Essays from the 1930s by Artists and Administrators*

of the WPA Federal Art Project, edited by Francis V. O'Connor, 1973, New York Graphic Society Ltd, Greenwich, Connecticut

Cavanagh, T., *Public Sculpture of Liverpool*, 1997, Liverpool University Press.

Cranny-Francis, A., *Sculpture as deconstruction: the aesthetic practice of Ron Mueck*, 2013, Visual Communication 12(1), online, available at: <https://tinyurl.com/l9sne4> [accessed 16.09.2016].

Croce, B., *Criticism and History of the Figurative Arts: The Present Phase*, 1919, cited in Philosophy, Poetry, History An Anthology of Essays by Benedetto Croce, 1966, translated and introduced by Cecil Spigge, London: Oxford University Press.

Curtis, P., *Patronage & practice: Sculpture on Merseyside*, 1989, Tate Liverpool, p158.

Elkins, J., *Afterword: On Beyond Research and New Knowledge, Thinking Through Art: Reflections on Art As Research*, 2005, edited by Katy Macleod and Lin Holdridge, Routledge, New York/London.

Erik H. Erikson, E., *Identity, youth and crisis*, 1968, New York: W. W. Norton Company.

Eugenides, J., *The Virgin Suicides*, 1993, Farrar, Straus and Giroux, New York.

Fagan, C. James, "Teamwork and co-creation lie at the heart": Dogsy Ma Bone Musical Launches Liverpool Biennial's Inaugural Touring Programme, 2017, online, available at: <https://tinyurl.com/ycvewk8u> [accessed 29.6.2018]

Fullard, G., *Sculpture and Survival*, 1959, The painter and sculptor, Vol.2, Nr.2, Summer.

Gasset, J., *The Dehumanization of Art and Notes on the Novel*, 1925, reprinted 1951, NY Peter Smith, with permission of Princeton University.

Giroux, H., *Public Spaces, Private Lives: Beyond the Culture of Cynicism*, 2001, Rowmann & Littlefield publishers, Lanham, Maryland.

Giroux, H., *Youth in a suspect society: Democracy or Disposability?* 2009/10, Palgrave Macmillan, New York.

Gliga, T., *The 'Knife Crime' phenomenon - A psychological perspective on youth knife culture*, date unknown, BPS Parliamentary Office, online, available at: <https://tinyurl.com/k5e38n6> [accessed 13.4.2017].

Golding, W., *Lord of the flies*, 1954, Faber and Faber, UK.

Good, A., *Archaeology of Daily Life, Ephidrismos Group (Piggyback Girls)*, date unknown, online, available at: <https://tinyurl.com/mmtvrdv> [accessed 03.01.2016].

Grossberg, L., *Caught in the crossfire: kids, politics, and America's Future*, 2005, Paradigm Publishers, London.



Harding, D., *Glenrothes Town Artist 1968 - 78*, online, available at: <https://tinyurl.com/kz9ome4> [accessed 13.2.2017].

Harding, D., *Decadent: Public Art - Contentious Term and Contested Practice*, 1997, The Glasgow School of Art.

Hatt, M. and Klonk, C., *Art history, Critical introduction to its methods*, 2006, Manchester University Press.

Hauser, A., *The Social History of Art, Vol I.*, 1951, New York: Vintage Books, p100

Heath, S. and Walker, C., eds. *Innovations in youth research*, 2012, Palgrave Macmillan, London/NY.

Helve, H. and Wallace, C., *Youth, citizenship and empowerment*, 2001, Published Aldershot: Ashgate.

Hirschhorn, T., *The Gramsci Monument, like all monuments, is made for eternity*, 2017, online, available at: <https://tinyurl.com/y749jpxj> [accessed 29.6.2018]

Horlock, N., *Just Wait for Me, Evaluation Report*, 2013.

Hörschelmann, K. and Colls, R., eds. *Contested bodies of childhood and youth*, 2010, Published Basingstoke: Palgrave Macmillan, London/NY.

Iannelli, L. and Musaro, P. (eds), *Performative Citizenship: Public Art, Urban Design, and Political Participation*, 2017, Mimesis International.

Johnson, C., *About the Mnemosyne Atlas*, 2013-16, online, available at: <https://tinyurl.com/k7wnone> [accessed 13.2.2017].

Kaprow, A., *Essays of the blurring of life and art*, 1993, Berkeley, CA, University of California Press.

Kester, G., *Conversation Pieces: Community and Communication in Modern Art*, 2013, University of California Press.

Kleijwegt, M., *Ancient Youth - The ambiguity of Youth and the absence of Adolescence in Greco-Roman Society*, 1991, Amsterdam, J.C. Gieben.

Koch, G. and K. Wight, *Roman Funerary Sculpture: Catalogue of the Collections*, 2006, Getty Publications, Los Angeles.

Kwon, M., *One Place after Another: Site-Specific Art and Locational Identity*, 2004, MIT Press, Massachusetts.

Levi, G. and Schmitt, J-C., eds. *History of Young People*, 1997, Belknap Press, Harvard University Press, Cambridge, Mass. and London.

Levi, G., ed. *A History of Young People in the West, Part I: Ancient and Medieval Rites of Passage*, 1999, Cambridge Mass. and London.

Levine, C., *Provoking Democracy: Why We Need the Arts*, 2007, Wiley-Blackwell,

UK.

Lingwood, J., *Juan Munoz: Monologues & Dialogues*, 1996, Madrid.

Linn, S., *Consuming Kid: The Hostile Takeover of Childhood*, 2004, The New Press, NY.

Lippard, L., *The Lure of the Local: Senses of Place in a Multicentered Society*, 1997, New York: The New Press.

*Liscard & Seacombe School Cluster Profile*, 2009, online, available at: <https://tinyurl.com/kzwhxj5> [accessed 13.2.2017].

Liu, L., *On the Edge of Critical Thinking - An Interview with W. J. T. Mitchell*, 2005, online, available at: <https://tinyurl.com/mv5coop>, [accessed 10.4.2017].

*Liverpool Biennial public art archive*, online, available at: <https://tinyurl.com/nyv8yjs> [accessed 13.2.2017].

*Lord of the flies*, 1963. [Film] Directed by Peter Brook, UK: British Lion.

Lucas, K., *Celebrations for Breaking Routine*, 2003, online, available at: <https://tinyurl.com/ybz9hkhn> [accessed 29.6.2018]

Manders, M., *Isolated Bathroom*, 2003, artist's statement, online, available at: <https://tinyurl.com/mtgmvz5>, [accessed 13.2.2017].

Manders, M., *Room, Constructed to Provide Persistent Absence, interview with Mark Manders*, 29 January 2002 Toronto, online, available at: <https://tinyurl.com/zyuo4ph> [accessed 13.2.2017].

Manders, M., *The Absence of Mark Manders*, 1994, artist's statement, online, available at: <https://tinyurl.com/zyuo4ph> [accessed 13.2.2017].

*Mapping UK's teen murder toll*, BBC News, online, available at: <https://tinyurl.com/brocuq> [accessed 13.4.2017].

Mattusch, C., *The Victorious Youth*, 1997, Getty Museum Studies on Art, Los Angeles.

McRobbie, A., *Feminism and Youth Culture*, 1991, Macmillan, Basingstoke.

Michaud, P-A., *Aby Warburg and the Image in Motion*, 2007, Zone Books, New York.

Miles, M., *Art for Public Places: Critical Essays*, 1989, Winchester School of Art Press.

Edward Morris, E. and E. Roberts, *Public Sculpture of Cheshire and Merseyside (excluding Liverpool)*, 2012, Liverpool University Press, Liverpool.

Müller, C., *Kindheit und Jugend in der griechischen Frühzeit*, 1990, Focus, Giessen, Germany.

Newell-Hanson, A., no one captures the awkwardness and possibility of youth like

rineke dijkstra, 2017, online, available at: <https://tinyurl.com/ycybrfo9> [accessed 29.6.2018]

Panofsky, E., *Die Deutsche Plastik des Elften bis Dreizehnten Jahrhunderts*, 1924, Kurt Wolff Verlag, München.

Prettejohn, E., *The Modernity of Ancient Sculpture*, 2012, Tauris, London.

*Public Monuments and Sculpture Association National Recording Project*, online, available at: <https://tinyurl.com/mojv9y5> [accessed 13.02.2017].

*Professionals blamed Oxfordshire girls for their sexual abuse*, report finds, 2016, The Guardian, online, available at: <https://tinyurl.com/myk6vbk> [accessed 16.4.2017].

Rank, O., *The Double: A Psychoanalytical Study*, 1971, reprint 1989, Karnac, London.

Ray, C., *Video Postcard: Charles Ray's School Play*, 2015, Art Institute of Chicago, online, available at: <https://tinyurl.com/mte8nkr> [accessed 29.03.2016].

Rea, B., *1904-1965 Sculpture (Retrospective Exhibition of Sculpture)*, 1965, Zwemmer Gallery, London.

Richter, G., *The sculpture and sculptors of the Greeks, revised edition*, 1967 (first edition 1929), New Haven and London, Yale University Press.

Riley, B., *Dialogues in Art*, Robert Kudielka (ed.), 2003, Thames & Hudson, London.

*Rochdale grooming case: nine men jailed for up to 25 years each*, 2016, The Guardian, online, available at: <https://tinyurl.com/hhkeh5d> [accessed 16.4.2017].

Rousseau, J-J., *Du contrat social ou Principes du droit politique*, 1762, France.

Schildt, A. and Detlef, S., eds. *European cities, youth and the public sphere in the twentieth century*, 2005, Published Aldershot: Ashgate.

Schindler, N., *Guardians of Disorder: Rituals of Youthful culture at the dawn of the modern age*, 1997, in Levi, G. and Schmitt, J.C., eds. *History of Young People (ancient and medieval Rites of Passage)*, 1997, Belknap Press of Harvard University press, Cambridge Mass; London.

Schnapp, A., *Young People in the Greek City State*, 1997, in Levi, G. and Schmitt, J.C., eds. *History of Young People (ancient and medieval Rites of Passage)*, 1997, Belknap Press of Harvard University press, Cambridge Mass; London.

Schor, J., *Born to Buy: The Commercialized Child and the New Consumer Culture*, 2005, Simon & Schuster, New York.

Selwood, S., *The Benefits of Public Art: The Polemics of Permanent Art in Public Places*, 1995, Policy Studies Institute, London.

Shute, R. and Sleet, P., *Child Development: Theories and Critical Perspective*, 2015,

Routledge, New York/London.

Skelton, T. and Valentine, G., eds. *Cool places: geographies of youth cultures*, 1998, Routledge, New York/London.

Spivey, N., *Understanding Greek Sculpture, Ancient Meanings, Modern Readings*, 1997, Thames & Hudson, London.

Sukarieh, M. and Tannock, S., *Youth rising? the politics of youth in the global economy*, 2015, Routledge, New York/London.

Taussig, M., *Mimesis and Alterity: A Particular History of the Senses: A Particular Study of the Senses*, 1993, Routledge, Oxford.

*The J. Paul Getty Museum*, catalogue, online, available at: [http:// https://tinyurl.com/mr4x38f](http://https://tinyurl.com/mr4x38f) [accessed 13.2.2017].

Tienda, M. and Wilson, WJ., eds. *Youth in cities: a cross-national perspective*, 2002, Published Cambridge: Cambridge University Press.

Unknown, *Modern British sculpture*, 1939, Country Life Limited, issued by Royal Society of British Sculptors, London.

Unknown, *Bebington - England's most desirable place to live (still!)*, Wirral View, online, available at: <https://tinyurl.com/k6ceasl>, [accessed 10.4.2017].

Unknown, *Blaze rips through Hall*, Wirral Globe, online, available at: <https://tinyurl.com/k7wzcf7> [accessed 13.2.2017].

Valentine, G., *Public space and the culture of childhood*, 2004, Published Aldershot: Ashgate.

van Heeswijk, J., Interview with Jeanne van Heeswijk, online, available at: <http://www.2up2down.org.uk/people/jeanne-van-heeswijk/> [accessed 29.6.2018]

van Heeswijk, J. and B. Jurgensen, *HOMEBAKED: A perfect recipe*, online, available at <http://www.biennial.com/journal/issue-2/introduction> [accessed 29.6.2018]

Vasari, G., *Lives of the Artists (1568)*, 1965, Vol.1, trans. George Bull, Penguin Books, London.

Visual Arts Cork: *Stefano Maderno (1576-1636)*, online, available at: <https://tinyurl.com/kkvx3ar> [accessed 13.2.2017].

Vitale, G., *Anthropology of Childhood and Youth: International and Historical Perspectives*, 2014, Lexington Books, Maryland.

Von Franz, M-L., *The Interpretation of Fairy Tales*, 1996, Shambhala Publications Inc., Colorado.

von Kleist, H., *On the Marionette Theatre*, 1994, cited in *Essays on Dolls*, 1994, trans. Idris Parry, Penguin Books, London.



Warnke, M., *Flüchtling ohne Schlepper. Aus dem Bildindex zur politischen Ikonographie*, Winter 2016, Zeitschrift für Ideengeschichte Idee, Heft XIII/4, online, available at: <https://tinyurl.com/kaygef3> [accessed 13.2.2017].

Wells, R., *Scale in Contemporary Sculpture: Enlargement, Miniaturisation and the Life-size*, 2013, Ashgate, Surrey.

Wind, E., *Art and Anarchy*, 1963, Faber and Faber, London.

Wood, S., *The Republic of Trees*, 2005, Faber and Faber, UK.

Woodson, S., *Performing Youth: Youth Agency and the Production of Knowledge in Community-Based Theatre*, 2007, in A.L. Best (ed.), *Representing Youth: Methodological Issues in Critical Youth Studies*, 2007, New York: University Press.

# Part 3

Appendix

Brigitte Jurack



## Grants for the arts application form

### Individual details

#### Your contact information

For groups of individuals or groups of organisations, one individual or one organisation will need to take the lead and have the main responsibility for managing the application and any grant. If you are the person or organisation taking the lead, you will be responsible for the grant and we will only make payments to your bank account.

We use this information to update your contact details.

First name	<input type="text" value="Brigitte"/>
Middle name	<input type="text"/>
Last name	<input type="text" value="Jurack"/>

What is your full address?

We will use this address if we need to write to you about your application. Please provide the full, correct postcode as we need it to process your application. Fill in as much of the address as you can, then press 'Search'.

Full postcode

Address name or number

Street

Locality

Town / city

County

Non UK Address

Which Arts Council region are you based in?

Phone number, including area code

Mobile number

Please give any other contact details.

Email address

Website address

Textphone

Fax number

If you or your main contact person requires written communication in alternative formats, please let us know your preference.

No preference

### Contact with us and local authorities

#### What advice have you received?

Have you received any advice from the Arts Council?

What type of advice did you receive from us? (Please tick all that apply)

Website

- Application pack
- Information sheets

Direct contact

- Went to a seminar or a workshop
- Met a member of staff



Phone

Phoned the enquiries team

Phoned the regional office

Phoned the Gfta centre

Written contact

By post or email

Other

Advice from a member of staff in regional office

Spoken to local authority staff

We work with local authorities and consult them about most applications. As part of this process we will also let them know the outcome of your application. You should discuss your activity with any relevant local authorities before you apply.

Please tell us the name and the local authority of the staff that you spoke to:

Name 1	<input type="text" value="Jackie Smallwood"/>	Local authority	<input type="text" value="Wirral"/>
Name 2	<input type="text" value="Colin Simpson"/>	Local authority	<input type="text" value="Wirral"/>
Name 3	<input type="text"/>	Local authority	<input type="text"/>
Name 4	<input type="text"/>	Local authority	<input type="text"/>
Name 5	<input type="text"/>	Local authority	<input type="text"/>

Any other contact

Please give details in no more than 10 words:

## Activity description and dates

### Description of the activity

We use the information in this section to assess your application.

All the questions relate to the activity you are asking us to support.

What is the name or working title of the activity you are applying to do?

Just Wait for Me

(No more than 50 characters)

Please give us a description (in no more than 50 words) of the activity you are asking us to support.

Tell us if your activity has any particular focus (for example, 'My activity is in a hospital setting' or 'Our activity will include work with young offenders'). This helps us to decide who should assess and comment on your application.

You will be able to give us more information about your activity when you write your proposal. (See the 'Your proposal' section of How to apply.)

My activity will take place in a public park. 'Just Wait for Me' is a set of public sculptures that portrait young people in a celebratory manner, providing a focal point for performative display and play. The development process will include workshops with young people in the local youth centre.

(No more than 50 words)

### Activity dates

When will your activity start and end?

You must allow enough time for planning your activity and for us to process your application. We need six working weeks after receiving a complete application to process applications for £10,000 or less, and 12 working weeks for applications for £10,001 and over.

If you do not give us enough time before your activity starts, we may not be able to assess your application. The start date for your activity should also include the planning and preparation time you need. For example, if an activity needs marketing, you should include enough time to do this. We will not fund any goods or services that you bought or ordered before you received an offer letter.

Start date

06/02/2012

End date

26/10/2012

### Activity location

We report to local and national government on where funded activity takes place. We also consult local authorities about activities that will affect their communities. To help us to do this we ask you to give us information on where your activity takes place.

Type of activity:

Non-touring

For more information about Touring activities, read our Touring information sheet

### Location details

This is activity that is happening in just one place or activity that is not taking place in any specific area (such as online work or a publishing project).

Is the activity taking place in one space or one venue?

Yes

**Location details**

Name	Postcode	Local authority
Central Park, Liscard, Wirral		Wirral

**People who benefit from your activity**

How many people do you estimate will benefit from the activity?

In the boxes below, please give an estimate for this activity. If possible, please also estimate how many people benefited from your activities in the last 12 months. If none applies, enter '0'. 'Participants' means people doing the activity, including education workshops. 'Audience' includes people going to an exhibition or performance, and people getting access to work that is printed, recorded, broadcast or available online.

Numbers benefitting from this activity:

Artists	3
Participants	30
Audience (live)	8000
Audience (broadcast, online, in writing)	30000
Total	38033

Numbers benefitting from your activities over the last 12 months:

Artists	15
Participants	150
Audience (live)	3000
Audience (broadcast, online, in writing)	40000
Total	43165

Is your activity directed at people who are unlikely to have taken part in this type of activity before?

Yes

What are the age ranges of the people who will benefit from your activity?

Selected age ranges

Please tick all relevant boxes:

- |  |  |
|--|--|
| <input type="checkbox"/> Children under five                   | <input checked="" type="checkbox"/> Young people aged 20 to 24 |
| <input type="checkbox"/> Children aged five to 11              | <input checked="" type="checkbox"/> Adults aged 25 to 64       |
| <input checked="" type="checkbox"/> Young people aged 12 to 15 | <input checked="" type="checkbox"/> Adults aged 65 and over    |
| <input checked="" type="checkbox"/> Young people aged 16 to 19 |  |

Is the activity you are planning directed at, or particularly relevant to, any of the following groups of people?

Tick all relevant boxes:

- Asian or Asian British
- Black or Black British
- Chinese
- Any other ethnic group

- Disabled or deaf people
- People at risk of 'social exclusion'

Activity is not specifically directed at any of the above groups

Do you think that your application includes activity which supports the Cultural Olympiad?

No

### Activity results

Please give the expected results of your activity.

We understand that your activity may change through the planning stages. Please estimate what you think will happen because of your activity, based on your current plans, and enter the appropriate number in each field. Enter '0' (zero) in any field which is not relevant to your activity.

Number of performance or exhibition days

18

Number of new products or commissions

3

Period of employment for artists (in days)

66

Number of sessions for education, training or participation.

20

(‘Participation’ means people doing the activity. Divide the day into three sessions - morning, afternoon and evening. A ‘session’ is any one of, or part of, one of these. For example, a half-day education workshop would be one session.)

### Financial background

Please download and read the following information sheet before completing your Income and Expenditure: Grants for the arts – example budgets

Are you registered for VAT (value added tax)?

No

### Income for your activity

Amount you have applied for

£18,000

Are you applying for 100% funding?

You should only enter cash expenditure to this screen. Please enter any support in kind on the Support in kind screen.



### Income from other sources

Income heading	Description	Expected or confirmed	Amount £
Earned income			
Local authority funding	Wirral	Expected	£10,000
Other public funding			
Private income	MMU Research grant towards casting costs	Expected	£3,000
<b>Income total</b>			<b>£31,000</b>

Please click on the button 'Add income line' to add an item of income to the budget.

### Activity expenditure

You should only enter cash expenditure to this screen. Please enter any support in kind on the Support in kind screen.

#### Spending (expenditure) activity for your activity

Expenditure heading	Description	Amount £
Artistic spending	Fee for 2 early-career artists @ £16/hr, 5 day @8 hrs/days: workshops+ publicity design	£1,280
Artistic spending	Fabrication: moulding (Castle Foundry)	£5,400
Artistic spending	Fabrication: Casting and finishing (Castle Foundry)	£21,600
Artistic spending	Installation in Central Park (Castle Foundry)	£1,440
Artistic spending	Evaluation, 2-day session	£500
Making your performance accessible		
Developing your organisation and people		
Marketing and developing audiences	Printing and distribution of leaflets and posters	£350
Marketing and developing audiences	Semi-permanent sign (Benson Signs)	£430
Overheads		
Assets - equipment, instruments and vehicles		
Assets - buildings for arts use		
Other		
If you are disabled or Deaf, additional access or support cost you need to manage the activity		
<b>Expenditure total</b>		<b>£31,000</b>

Please click on the button 'Add spending line' to add an item of expenditure to the budget.

Income total

### Support in kind

#### Support in kind

Description	Expected or confirmed?	Amount £
Brigitte Jurack, waived artist's fee, 56 days @ £150/dy	Confirmed	£10,080
Brigitte Jurack, waived studio costs, 3 months at £ 210/mth	Confirmed	£756
Wirral MBC	Expected	£5,000
Friends of Central Park	Expected	£100
Brigitte Jurack, provision of workshop materials (clay)	Confirmed	£336
MMU - firing costs for model figures	Confirmed	£180
Wirral MBC - production of permanent sign for sculpture	Expected	£300
		£16,752

For more information about Support in kind, read our 'Support in kind section of the Help notes'

Please click on the 'Add support line' to add an item of Support in kind to the budget.

## **Proposal**

Our experience with Grants for the arts has shown that people applying prefer to include a written proposal rather than answer a lot of detailed questions. We are therefore asking you to complete a proposal about the activity you want us to support. This is a very important part of your application. We will use your proposal and the application form to assess your application.

The amount of information you need to provide in your proposal depends on how complicated your activity is and how much money you are applying for. Your proposal should be no more than:

2000 words for applications between £1000 and £10,000; and

8000 words for applications £10,001 and over

For each section listed below (under 'Description') we provide a link to more guidance about what information we need.

For more advice on our assessment and overview criteria please read our Understanding the assessment criteria and overview information sheet.

We need extra information for certain activities (see links below).

Applications for buying equipment, instruments and vehicles

Applications for buildings to be used for the arts

## You and your work

### Background

Central Park lies in the heart of Liscard, Wallasey, in the Borough of Wirral. Surrounded by largely terraced housing, it became a community park around Liscard Hall (1832), formerly a merchant's house. The building was more recently used as an Art School but suffered an arson attack in 2008 and the remains subsequently removed.

As part of the Council's commitment to the Park, an upgrading of the local play area and a fitness trail is planned, along with some form of art intervention for a landscaped area where Liscard Hall once stood. The Friends of the Park and Wirral Metropolitan Borough Council (MBC) undertook initial consultation with some young people in 2010.

Since March 2011, lead artist Brigitte Jurack has been running creative workshops at the local Youth Hub. These workshops have focused on designing a "hang out focal point" for young people in Central Park. In August 2011, some of the initial models were presented at a community consultation day within Central Park.

### What I want to do

This proposal is for a permanent sculptural work entitled 'Just wait for me'. It has developed fluidly from this initial research and development phase, in consultation with Wirral MBC and the Friends of the Park.

'Just wait for me' aims to use sculpture to portray young people in a celebratory manner and provide a focal point for performative display and play.

Over recent years Jurack has created sculptural figures and shown work in galleries and public spaces in Wales, Ireland, Greece, Norway and various venues across the U.K. She lives within walking distance of Central Park and considers that a challenge lies in making the magical out of the everyday. As noted by former Director of Liverpool Biennial Lewis Biggs on a visit to Jurack's studio in the preparation of this application, it is quite unique to have an artist driven by that passion to create a new artwork on his or her own doorstep. In this sense 'Just wait for me' is all about a 'local' artist investing in the 'local' community.

Working with local young people – and Youth Workers – has been an invaluable experience for Jurack, creating a dynamic relationship in the sharing of ideas and thought-processes of creative practice, and in focusing this thinking within her local community. It has also more directly informed the gestures, stances and interplay between the proposed sculptures.

Having said that local engagement is key to this proposal, Jurack also conceptualises the work in relation to contemporary practice internationally - specifically artworks focusing on the transitional stage between childhood and adulthood. Recent examples include 'Dream' by Jaume Plensa in St. Helens that idealises childhood through an anonymous static young female closing her eyes to her surroundings, and the new commission for the Fourth Plinth in Trafalgar Square ('Powerless Structures, Fig. 101' by Elmgreen & Dragset) which focuses on childhood play in a similarly generic visualisation. Late 20th early 21st century sculptures of youth, such as Ron Mueck's recent sculpture 'Youth' (2009) reveal a powerless teenage victim whilst Pia Stadtbauer's 'Hirtenknabenspiel' (2004) and Stefan Balkenhol's statues, depicting young men and women show a 'proud, if reticent, self-reliance'.

These themes have been largely absent from public sculpture in the 20-21st Centuries. Historically figurative statues in parks have depicted rich and powerful local figures – 'achievers', industrialists or politicians. These figures are mostly in a formal standing or sitting pose and rose heroically on plinths. Jurack aims to explode this convention by celebrating the local youth at the point of waiting, waiting to grow older, waiting to find their direction in life - their poses also suggestive of the 'play' which dominates the social interaction of childhood.

It is Jurack's intention that these generic experiences of youth – waiting and play - invite older park visitors to project their own memories of youth onto the figures. To this end a clear but open narrative is proposed between three figures (statues). Perched up on a brick plinth, situated near the former Hall site will be the statue of a seated 'girl', legs pulled in tight to the body, with a brightly coloured jumper stretched over the knees. Her gaze will be cast down, she will appear a little hesitant, kind of waiting, 'unsure', but safe under that jumper. At a short distance from her will be a statue of a couple of young people piggy backing.

Jurack is interested in the waiting girl as a 'universal' contemporary image of youth associated with parks – although obviously not institutionally 'celebrated' in the park statues. She is also mindful of the symbolism of the

Piggy back: used as a friendly, playful gesture amongst young people, and often used as a popular poster image for young people holidays, suggestive of “these young people are having fun”. It also symbolises “ helping each other”, “trying to get higher in order to see more”, “showing one’s affection”, “and showing one’s physical strength”. Whilst an adult piggy backing a child is seen as an act of the stronger helping the weaker, young people piggy backing each other is understood as a game. Piggy Back races are re-emerging as fun charity races organized by young people for young people (i.e. Colchester Piggy Back Race, 02.10.2011). As ‘play’, just like skateboarding, it combines playfulness of contact sports with physical strength and bravado of young people. Intriguingly there are small ‘domestic’ statuettes of the classical period, which show adolescent girls piggy backing, portraying the popular game of Ephedrimos.

Names, skills and experience of artists and other main people involved and how the project will develop their skills

Lead Artist.

Brigitte Jurack has considerable standing regionally, a national and international exhibition profile (see CV) and a track record of working with young people and reflecting their aspirations in collaborative exhibitions, sculptural works or arts events.

In 2002 Jurack was commissioned by Locws International in Swansea to create the temporary public sculpture ‘Junge mit Jacke (Youth with Jacket)’. The piece was so successful that its exhibition period was extended by two months.

In 2010 Jurack installed a temporary sculpture for young people in the gardens of the Irish Museum of Modern Art (IMMA), Dublin. The sculptures ‘girls (waiting)’, ‘boy with mouse’, ‘boy with parasol’, ‘Monument for Damien’ and ‘girl with fire’ have been exhibited at the Bluecoat, Liverpool; the Ceramic Biennial, Stoke on Trent; the British School in Athens and at the Holden Gallery Manchester, cementing the significance of a recent figurative trend in her practice.

Jurack has a strong track record of working with young people through hands on workshops and exhibited collaborative artworks, included in exhibitions at IMMA, Gallery Format in Oslo and Town Mill Galleries in Lyme Regis.

As founding member of the international artists’ collective ‘Foreign Investment’ Jurack has worked with a diverse range of participants engaged in performative events celebrating specific locations. These events have included ‘Moonshine Walk’ for the former mining community of Sutton Manor, ‘Topping-out’ for Arts Council England’s new Manchester offices and ‘Gold for Oslo’ for children in Oslo’s multi-cultural neighborhood.

Assistants

The ‘Just wait for me’ public sculpture will be assisted and supported by two early career artists.

- Daniel Taylor (see CV) is a recent graduate who combines excellent drawing skills with an ability to manage all aspects of communication and publicity relating to the art project.
- Sarah Stockdale (see CV) is a recent graduate who will assist in the running of workshop sessions.

How the activity fits in with current work and its future development

‘Just wait for me’ builds upon Jurack’s sculptural works of the previous ten years and a more recent figurative strand. It will enable further exploration of a current theme in exploring the social status and experience of young people. It is important to her developing collaborative approach, particularly in sharing the experience of sculptural practice – the making as a skills-driven and material-led process.

More broadly, the work emerges from her interest in creating relevant and contemporary sculpture with communities. Jurack has come to recognize that artists have important contributions to make to their own locality and for this reason, ‘Just wait for me’ is importantly artist-driven.

The aims of the activity and how they will be achieved

‘Just wait for me’ seeks to empower, raise expectations, and instill pride and a sense of belonging. It seeks to add value to the young people’s experience of their environment enabling them to actively influence what is going on in “their” park and to contribute to society by shaping the environment.

The finished sculptures will celebrate difference (“its okay to be different”) and expresses in public in a solid material a kind of vulnerability and bravado experienced by the young.

The project will have two main strands:

A programme of twenty two-hour drop-in workshops at the Youth Hub in Liscard focusing on photography and modeling with clay. Young people will use analogue photography to capture poses of hanging around, perching and piggy backing. Using selected photographs, they will be introduced into basic techniques of making ceramic statuettes. Initially hand modeled, the small figures will be covered with photographic transfers made from their own photographs (a digital process whereby the photos/ sections of the photos can be collaged onto the statuettes).

The development, construction and installation of a unique set of three figurative sculptures depicting young people for the former Liscard Hall site. The actual design of the sculptures will be based on the photographs and models made at the Hub.

During the actual construction of the life size sculptures, the young people of the Hub will be given the opportunity to witness the various stages of the production (organised studio and foundry visit). Upon completion, the sculptures will be installed alongside the environmental upgrading undertaken by the Council.

How will I explore new ideas and concepts in this activity?

The exploration of new ideas and concepts for this activity has informed work to date, as previously outlined in this proposal. However collaboration is an iterative process and the intention here is to continue working with young people to nuisance the work until and during fabrication and installation. Thus far Jurack's collaborations with young people led to time-based (animation, performance) outcomes for both, the gallery and the public domain. With 'Just wait for me', the emphasis of the work is clearly directed towards permanence and visibility, combining time-based, digital and analogue techniques in the scoping, design and construction stages.

How the activity relates to best practice in this area

The conceptual contemporary arts framework for this work is also outlined previously.

Understanding young people

Crucial to 'Just wait for me' has been Jurack's research and development work with the local young people. From these sessions, it has emerged that the young people in Liscard

- have little first hand experience of the visual arts
- do not access Liverpool's rich and diverse cultural programme
- feel disenfranchised
- feel very negative towards progress, including any possible artwork ("it won't get done", "they never listen to us" or "it will get trashed anyway")

However, they have been very articulate and innovative in expressing ideas on how to improve Central Park and are able to articulate their needs. This energy will feed the new public artwork - its completion and their engagement with it over a prolonged period will provide a physical manifestation of their input and their importance in the park.

Quality

Please refer to attached CV.

Within the contemporary art world outside London quality has historically been perceived as coming from elsewhere. Jurack has experienced this first hand in the reception of her work in other cities and although Liverpool institutions with a national remit such as the Bluecoat have been working to overturn this problematic perception, quality permanent public art works have been commissioned with the purpose of importing internationally established artists work to Liverpool.

Laurie Peake, Public Art Curator at Liverpool Biennial, described the Jurack's proposal as "as inspirational and ambitious as the major '2up2down' work currently undertaken by Dutch artist Jeanne van Hesjwick in Aintree". Peake and Biggs also suggested that with 'Just wait for me', Wallasey could acquire an artwork that makes as much impact as Antony Gormley's 'Another Place' in Crosby.

Biggs commented on the uniqueness of the project and the memorable gestures suggested; sitting, half hiding under a colourful jumper, watching two young figures mess about piggy-backing.

Peake went on to suggest that "no other Park would have something as special as this", pointing out that the young people's self-esteem would be exponentially increased by involvement in the project, especially as they



have been involved since the beginning and have built up a working relationship with the artist.

How other artist or people with other skills will be involved

Initial and ongoing consultation for 'Just wait for me' includes a wealth of local input and support from professionals experienced in this field:

- The Wallasey Youth Hub users and staff (Lisa Joy, Youth Worker)
- The Friends of Central Park (Chris Davies, chair)
- The Wirral Borough Council Landscape Architect Department (Jackie Smallwood)
- Laurie Peake, Liverpool Biennial, public art director and mentor to the project
- Sarah-Jayne Parsons, Director of Exhibitions, Bluecoat, Liverpool
- Lewis Biggs, former Director of Liverpool Biennial
- Janet Batselaar, Principle Lecturer in Youth Work at MMU, Manchester and mentor to the youth engagement aspect of the project
- Birkenhead Park Visitor Centre (Anne Litherland, Senior Ranger)
- Paul Kelly, Arts Development Manager at Lancashire Arts Development Service
- Alan Dunn, public artist, Wirral
- Sarah Kenton, Wirral Borough Council Arts Officer
- Colin Simpson, Williamson Art Gallery, Birkenhead

During production stages, the following collaborators will be involved:

- Castle Foundry, foundry work and safe installation of the work
- Design and publicity (two early career artists)
- Friends of Central Park, Youth Service Park ranger and Wirral Landscape Architect (general planning and landscaping issues)

How the public engage with your work

Details about the people the activity will reach – geographical context

Central Park is surrounded by two neighboring wards: Liscard and Seacombe. Densely populated with social housing and Victorian two-up two-downs, the total population of 16-64 year olds in 2001 was 8,900. Recent statistics show above-national levels of people claiming out of work benefit (July 2011: 21.2% , national average: 12.3% Wirral average: 17.6%); high levels young people out of work : 31.3% (Wirral 32%, National 29.4%), of childhood obesity at reception and level 6 ( 50% higher than on Wirral) and a high percentage of adults with low level qualifications (2001): 40.6% no qualifications of recognized level (35.8% national average); 48.5% low level qualifications ( 43.9% national average) and 10.6% high level qualifications (20.4% national average).

"Seacombe appears to be have significantly more acute child wellbeing issues than Liscard (as measured by the Child Well-being Index) scoring worse than Liscard on every domain except environment. Both areas score worse than Wirral on every domain indicating this is an area of acute deprivation." ... "obesity at both Reception and Year 6 are higher in Liscard and Seacombe than Wirral. In Seacombe, obesity at Reception is 50% higher than the Wirral"; Young People NEET (not in education, employment or training), August 2007, Ward % NEET: Liscard 13.30%, Seacombe 22.00%; Wirral 11.90%; North West 10.80%, England 8.60%" (Source: Wirral Compendium of Health Statistics, 2009, [http://info.wirral.nhs.uk/document\\_uploads/school-cluster-group/Liscard-Seacombe.pdf](http://info.wirral.nhs.uk/document_uploads/school-cluster-group/Liscard-Seacombe.pdf))

Seacombe and Liscard rank as lower super output areas (LSOA). They show multiples levels of deprivation and rank amongst the 3% most deprived nationally. (IMD Rank 2004, sourced in: Wirral Play Strategy, 2007-2012, page 18)

Central Park is the largest and only park in these two wards and is sandwiched between recent redevelopments in New Brighton (Floral Pavilion) and the neighborhood renewal area of Seacombe.

Central Park is heavily used by all ages and population groups for children's play, dog walking and organized sport such as cricket, football, bowling and fishing. A walled garden houses a small social enterprise café provides tea and coffee for outdoor consumption only.

The proposed location for 'Just wait for me' is the most central and busiest part of the park, near to the gated children's play area, the teen hang out basketball hoop and the football training area.

Local consultation  
During a community Open Day in Central Park in August 2011, Jurack presented play park ideas and park

projects for young people from around the world. A number of visitors commented "it is about time that something good is happening here", "there ought to be something for young people to do, like a skate facility" or "at least a table tennis and some water feature and fancy seating".

Details about how people will be reached, including press and marketing activity

In Spring 2012, in conjunction with Friends of the Park, a selection of in-progress models and photographs will be on public display within Central Park's Cricket Club. The excellent setting will be used as a launch pad for the project, with promotional posters, media announcements and listings.

Social networking has become increasingly relevant for the dissemination of information relating to new artworks. That will be taken on board, aligned with existing press departments within Wirral Borough Council. International art press is a great challenge. Contacts at Liverpool Biennial and Jurack's membership of the International Sculpture Network (a pan-European professional network) will assist in raising the national and international profile of the sculptures in view to extensive press coverage in specialist journals such as Artist Newsletter, Sculpture International, International Sculpture Centre, Ixia, Artreview, Art and Architecture Journal and Youth Arts online.

Promotional material as part of the public installation of the sculptures

- Posters displayed around Central Park announcing the exhibition
- Exhibition leaflet distributed door-to-door and in schools and libraries
- Feature on the council Youth Website
- Announcement in the quarterly Birkenhead park newsletter and Website
- A radio interview with 7waves (Wirral community radio programme)
- Listing on BBC radio Merseyside
- Building social networking profile through Twitter and Facebook
- Press (Echo, Daily Post, Wirral Globe)

Signage

A temporary sign will be installed at the Liscard Hall site Central Park, announcing the forthcoming sculptures through a visualization and short text, keeping the local community clearly informed as to developments. This sign will be installed when the general groundwork for environmental improvements (scheduled for Autumn 2011) begin. The artist anticipates the final installation of the sculpture to take place in late Summer 2012 (September).

Details of how public and private partners have been involved in planning the activity

Jurack was invited by the Friends of Central Park to join their advisory Steering Group in relation to developments within Central Park. She has met with Wirral MBC at various stages during the development of ideas and a draft of this application was presented to Wirral MBC in September 2011. Following extensive discussion with council's landscape architect Jackie Smallwood the now tabled application has taken the comments of Wirral MBC representative on board. The seated figure, originally planned as a seated skate boarder on top of the existing wall, has been replaced by a seated female, on a specially designed plinth taking on board Health and Safety concerns, the listing statues of the wall and the 'controversial nature' of the skate board image.

How access, equality and diversity has been considered

Physical access and free access is guaranteed at both the Birkenhead Park Visitor Centre and the Central Park site and public transport is available to access both sites. A wide cross section of the community uses both parks, which do not exclude anybody. While Wallasey is a relatively non-diverse community, the international importance of Birkenhead Park (a ten minute bus journey from Central Park), the re-development of New Brighton and the Cultural Olympiad 'Cloud' will increase the breadth and diversity of visitors to Wallasey.

Making it happen

Development workshops, mid-February until end of March 2012

The lead artist oversees one early-career artist working with young people at the Youth Hub developing photographs of themselves sitting and piggy backing. These photographs will form the basis for a set of small clay sculptures that will be adorned with the original photographs (ceramic transfers) before being fired at Manchester Metropolitan University as part of their in-kind support.

Lead: Brigitte Jurack

Support: Sarah Stockdale

Facilitation: Lisa Joy

Project exhibition in Central Park, April 2012

The figures produced at the workshops will be exhibited within Central Park Cricket Club to launch the project.

Lead: Daniel Taylor

Support: Sarah Stockdale

Facilitation: Friends of the Park and Central Park Cricket Club

Production, installation and documentation of large-scale public artwork in Central Park, April – September 2012

The lead artist selects three models to interpret, modify and develop into life-size clay sculptures. The young people will be given an insight to this process through visits to the artist's studio in nearby Birkenhead and one visit to Castle Foundry in Oswestry, where the final metal sculptures will be cast. Castle Foundry will deliver and install finished sculptures, working in conjunction with Wirral MBC. Full documentation of artwork by lead artist and Wirral MBC.

Lead: Brigitte Jurack

Casting and installation: Castle Foundry

Facilitation: Wirral MBC

Promotion, monitoring and evaluation

After installation, the early-career artist will oversee press and publicity, working in conjunction with Wirral MBC. Post-installation evaluation to take place.

Previous experience of successfully managing similar activity

Jurack's experience with 'Foreign Investment' has seen her manage and organize large-scale art projects such as 'Moonshine Walk' (project budget £12,000), 'Oslo Gold Exchange' (£10,000), 'Irfaran- travel and work' (£10,000) and 'Topping-out' (£14,400). These projects required operating within a diverse set of contexts such as Rio de Janeiro, Oslo and Istanbul where clear communication and organisational skills become paramount.

In her role as Programme Leader in Fine Art at Manchester Metropolitan University, Jurack has gained a wide range of teamwork, administrative, management and budgeting skills.

Please see CV for further experience.

The involvement of, and support from, any partners, including others providing funding.

Wirral MBC will be managing the broader environmental improvement and regeneration plan for Central Park, supporting and co-ordinating the involvement of key partners, including those involved in the 'Just wait for me' project and investing £10,000 directly into the manufacture of the sculptures. A Wirral MBC member will be recruited on the project support group. A decision to support this project was taken on 27.9.2011 at a meeting between the lead artist and Jackie Smallwood, pending on securing additional funding.

Wirral MBC will also provide a further £5,000 in-kind support covering:

- Hire of Youth Hub
- Attending meetings
- Publicity support
- Preparation of ground prior to installation

MIRIAD (Manchester Institute for Research and Innovation in Art and Design) at Manchester Metropolitan University will provide funding to release the lead artist Brigitte Jurack from her part-time teaching commitments for six weeks (equivalent to £2,230) enabling her to fully concentrate on the production of the work in the lead up to the teaching free period during the summer. Additionally, they will be investing a further £750 in-kind, provide professional mentoring Youth Work expert Janet Batselaar (two mentoring sessions), display cabinets for Cricket Club exhibition and AV equipment and ceramic facilities necessary for the project.

Friends of Central Park will be providing £100 in support in-kind, chiefly through the provision of the Cricket Club as a meeting room free of charge.

As the project is artist-led, no lead artist fee is being requested. Brigitte Jurack will invest 56 days into 'Just wait for me' at an equivalent cost of £10,080. She will also absorb studio costs at an equivalent of £756.

What risks have been identified to successfully completing the project, and how will they be managed?

Wirral MBC will also be responsible for providing a contract between the artist and the council. Wirral Council will be given copyright permission to use images of the sculptures for publicity material (tourism publicity, Wirral MBC publicity).

In projects of this type with many partners, both contracted and informal, the possibility exists that collaborators may exit from the process. To counteract this, Wirral MBC will assist in the drawing up of contracts between partners, including between lead artist and Wirral MBC, between lead artist and support artists and between lead artist and fabricators.

An Advisory Group will be formed to meet regularly during the project to monitor progress and budgets and foresee upcoming risks. Members to include:

Jackie Smallwood (Wirral MBC)  
Steve Chan/Lisa Joy (Wirral MBC Youth service)  
Paul Kelly (Arts Development Manager at Lancashire Arts Development)  
Laurie Peake (Liverpool Biennial and Bromborough Basin Redevelopment)

To help the social embedding of 'Just wait for me', advice will be sought from key North West professionals experienced in delivering high-quality public artworks in diverse contexts. In particular, Paul Kelly, former Liverpool Housing Action Trust Community Development Manager and now Arts Development Manager at Lancashire Arts Development Service is on board. During his time at HAT, Kelly managed major public artworks that pushed the boundaries of private-public engagement. Vong Phaophonit's 'Outhouse' in Woolton, a delicate glass structure, in particular faced vehement opposition from a public wary of a glass structure and such a conceptual 'folly' form. Kelly was instrumental in working with the community, commissioner, press and artist to go through a public art journey that ended with a highly successful public artwork.

Kelly's experience and advice will be invaluable during 'Just wait for me'. Wirral MBC will provide additional social, legal and administrative advice and support and the Youth Hub will assist in relations with young people.

Castle Foundry will undertake the manufacture and installation of the sculptures. Castle Foundry has been casting and installing public artwork in the North West of England for over twenty years, including works by Tom Murphy, Laura Ford and Sophie Ryder (see [www.bronzefoundry.co.uk](http://www.bronzefoundry.co.uk)).

The artwork will satisfy all Wirral MBC's Health & Safety and public liability requirements. Materials will be safe and any potential climbing to seated figure will be considered.

What are the long-term implications of the activity on the artist's organization and how does this activity fit into a business plan?

It is proposed that the artwork is designed to last at least twenty-five years. Long-term maintenance of the sculptures will contractually sit with Wirral MBC.

'Just wait for me' will form part of the Wirral's new cultural trail, along with Cloud, New Brighton, Birkenhead Park and Port Sunlight and greatly enhance Jurack's public art portfolio.

For Jurack, the project is a further embedding of her practice within her local geographical context while pursuing an international exhibiting profile. In May 2011 she established a new studio in Birkenhead, opposite the Williamson Art Gallery, and opened it to the public during the Wirral Open Studio Weekend in September 2011.

#### Finance

How I have worked out the figures in my budget

Staff costs - early career costs have been set at same rate as current University teaching assistant rates (Tutor B). Manufacture - all materials have been sourced at the most economic supplier while maintaining quality of material. Castle Foundry were selected as the most appropriate fabricators in terms of pricing (COMPARE) and locale in relation to travel costs. Publicity - services such as door-to-door leafleting have been sourced from businesses within same postcode as sculpture location.

#### Match funding

Jurack have provisionally secured match funding for the total project costs through direct and in-kind support. Wirral MBC have agreed to support the project, pending a successful Arts Council England application.

#### Effect the activity will have on your long-term financial position

This is a discrete project and will have no negative effect on Jurack's long-term financial position.

#### Managing budget

The Advisory Group will meet every six weeks to manage and monitor the budget.

#### Confirmation of funding

Wirral MBC to confirm funding following ACE decision. Wirral MBC funding is attached to the development of the former Liscard Hall site.

#### Cash-flow

Castle Foundry will be paid in three installments, the last of which will be one month after sculpture installation and will be covered by final ACE payment.

#### How budget and cash flow will be managed

Jurack will manage the budget according to the stated budget outline. 'Just wait for me' has a voluntary Advisory Group that will operate much like a board, meeting on a six-weekly cycle throughout the project to monitor budget expenditure against the original proposal. On a day-to-day basis Jurack will be managing expenditure. She has a strong track record of doing so, managing project budgets of up to £12,000. This experience includes managing cash flow for both fabrication projects – and related contracts – and events/ engagement projects.

#### Budget management meetings and outline of agendas for the meetings

##### 7.2.2012 Advisory group meeting

Contracts drawn and signed  
Workshop planning including materials

##### 27.3.2012 Advisory group meeting:

Review of budget  
Publicity for project exhibition in Cricket Club  
Evaluation of workshop phase

##### 7.5.2012 Advisory group meeting

Review of budget  
Evaluation of exhibition  
Purchasing metal for construction of armature  
Arranging studio visit for young people  
Signing off manufacture of temporary sign to be installed in Central Park

##### 18.6.2012 Advisory group meeting

Review of budget  
Studio update  
Foundry update  
Site update

##### 24.7.2012 Advisory group meeting

Review of budget  
Contracting Castle Foundry  
Discussing publicity for September  
Arranging Foundry visit for young people  
Signing off publicity material for printing

##### 4.9.2012 Advisory group meeting:

Review of budget  
Signing off construction of base/ plinth for sculptures  
Publicity update

##### 16.10.2012 Advisory group meeting

Review of budget  
Résumé of project management  
Evaluation



#### Evaluation

"For an artwork to be public, it must invite engagement not only from different groups but also between them. If negotiation between diverse social identities is not invited, then the artwork is not public" (Dr. G. Rose, Public Art Research Project, The Open University).

Evaluation of the workshops held at the Youth Hub Wallasey will be managed by Youth services and the Advisory Group. The Youth Services will look for the quality of engagement and respect shown to the young people in their contributions to the project and processes.

The evaluation will be conducted using questionnaires and will focus on the nature and quality of the experience of the young people on the workshops. As their first participatory artwork activity, it is crucial to the Youth Services to quantify the transformative nature of participation.

The Youth Hub has only opened in late summer 2010, and is still exploring different "drop in" activities (band practice, street dance) and has a keen interest in evaluating 'Just wait for me' as a model of engaging the young people in art.

Jurack will attend the Evaluation Toolkit day seminar by Ixia. The Toolkit Public Art: A Guide to Evaluation (2009) stresses the need for short and long term evaluation of a public art project and the need to articulate mutually agreeable outcomes at the onset of the project.

These outcomes will include:

- Working with young people and involving them in the project
- Shaping and beautifying the local environment through art
- Providing a unique and high quality artwork
- Involving other park users in the art project as part of the general environmental upgrade of the park
- Improve the image of the park and the people who use it
- Developing constructive relationships between WMBC, the various project partners and the artist.
- Creating a positive, celebratory image of young people which becomes a focal point on the former Liscard Hall site

The Evaluation of the permanent sculpture in the park will be conducted shortly after its completion (October 2012) and will be followed up by an evaluation undertaken in the following summer, when the park is also used at dusk. The artist will ask independent community- and youth art advisor: Naomi Horlock based on the Wirral (responsible for Vide Art, Williamson Art Gallery, and former Young Tate leader) to conduct these evaluations. Fully aware of the difficulties in involving a good number and a representative group of community members in the evaluation, Naomi Horlock will be combining quantitative and narrative approaches, and will be conducting the evaluation alongside organized Open days, Play Ranger days and in the Park's own community café.

Reason for no match funding

--

## Monitoring information

### Monitoring and reporting information

We use the information in this section to report how we have spent our funding from the National Lottery.

In this section, you must answer all the questions. If you prefer not to provide some of the information, you can tick the 'Prefer not to answer' box. We may use this information to report to the Government or to monitor the different backgrounds of people who receive grants.

This information will not be used to assess your application.

### Ethnicity

Please tick the box that applies to your background:

#### White

- British
- Irish
- Any other white background

#### Asian

- Asian Bangladeshi
- Asian Indian
- Asian Pakistani
- Any other Asian background

#### Black

- Black African
- Black Caribbean
- Any other Black background

Chinese

#### Mixed

- Asian and white
- Black African and white
- Black Caribbean and white
- Chinese and white
- Any other background from more than one ethnic group
- Any other ethnic group ( Please give details below.)

Prefer not to answer

### Disability status

Do you consider yourself to be disabled?

No

### Gender

Are you

Female

## Supporting evidence

Our assessment of your activity will be based on the information contained in the completed application form and the written proposal. Therefore all relevant and essential information should be included within the main body of the application.

Supporting information should only be used to provide evidence of previous work and activities. If you do need to refer to supporting information in your proposal please clearly state where it can be found. If supporting documents are essential to the understanding of your proposal these should be clearly referenced within the main text.

Evidence of previous work is useful to us as it is not always possible for us to see or experience your work first-hand. This could include:

an evaluation of your work

other people's views on the quality of your work (for example audiences, people taking part, readers, critics or other artists)

links to other sources of information about your work such as a website

a small sample of images of your previous work or of work in progress

evidence of who takes part in and attends your activities and how you reach them; or

other proof of your past work.

Other supporting documents that are useful to include are:

Cash Flow / Full budget breakdown identifying ACE investment

Examples/mock-ups of the work you are creating

Delivery schedule / Time line of events

## Attachments and links

Description	Link to open / download	File Size (MB)
Brigitte Jurack website	<a href="http://www.brigittejurack.de">http://www.brigittejurack.de</a>	
Foreign Investment website	<a href="http://foreign-investments.com">http://foreign-investments.com</a>	
<b>Total</b>		

## Attachments

### CV

Please attach your CV

A Curriculum Vitae (CV) will help us learn more about what you have done in the past. If you are an organisation, please include a CV for each main person involved in the activity, or more information about them.

### National lottery

Do you, or does your organisation, object to receiving National Lottery funding for religious reasons?

## Declaration

### Data protection and freedom of information

We are committed to being as open as possible. This includes being clear about how we assess and make decisions on Grants for the arts and how we will use your application form and other documents you give us. We are happy to provide you with copies of the information we hold about you, including our assessment of your application.

As a public organisation we have to follow the Data Protection Act 1998 and the Freedom of Information Act 2000. We have a data protection policy which is available from our website.

We also have an information sheet about freedom of information. You must read the 'How we treat your application under the Freedom of Information Act' section of 'How to apply' before you sign your application. This information is also available from our website.

By signing this application form, you agree to the following:

1. We will use this application form and the other information you give us, including any personal information, for the following purposes.

To decide whether to give you a grant.

To provide copies to other individuals or organisations who are helping us assess and monitor grants, including local authorities, other lottery distributors and organisations that award grants. After we reach a decision, we may also tell them the outcome of your application and, if appropriate, why we did not offer you a grant.

To hold in our database and use for statistical purposes.

If we offer you a grant, we will publish information about you relating to the activity we have funded, including the amount of the grant and the activity it was for. This information may appear in our press releases, in our print and online publications, and in the publications or websites of the Department for Culture, Media and Sport (DCMS) and any partner organisations who have funded the activity with us.

If we offer you a grant, you will support our work to campaign for the arts, contributing (when asked) to important publicity activities during the period we provide funding for. You will also give us, when asked, case studies, images and audio-visual materials that we can use to celebrate artistic excellence.

I confirm that, as far as I know, the information in this application is true and correct.

Do you agree with the above statement?

Name

2. You have read and understood the section 'How we treat your application under the Freedom of Information Act'. You accept how we generally plan to treat your application and other related information if someone asks to see it under the Freedom of Information Act 2000. You accept that the information sheet does not cover all cases, as we have to consider each request for information based on the situation when we get the request.

Tick this box if you consider that we should treat your proposal as confidential information.

Tick this box if you consider that we should treat your financial information, such as your budget and any business plan, as confidential information.

Tick this box if there is any other information you have provided that you consider to be confidential information.

If we offer you a grant and you have ticked any of the boxes above, we would generally treat that information as confidential until your activity ends (according to the date you gave us in this application).

Tick this box if you consider that we should treat that information as confidential after your activity ends.

3. You agree that we can keep you informed of our work and pass your contact details to organisers of arts marketing activities, conferences and training events.

Tick this box if you do not want us to keep you informed of our work.

Tick this box if you do not want us to pass your contact details to organisers of arts marketing activities, conferences and training events.



## Grants for the arts

### Interim activity report form

You can download this document from our website at <http://www.artscouncil.org.uk/funding/grants-arts/after-you-apply/if-you-are-offered-grant/>

Applicant: **Brigitte Jurack**

Activity name: **Just wait for me**

Unique reference number (URN): 18949125

Arts Council regional office: **NW**

#### Introduction

This interim report form must be submitted to meet your condition of payment release where specified on your payment schedule.

Please refer to your original application, and any changes you agreed with us, when you complete this interim report form.

Your interim report tells us:

- what has happened to date with your project
- your interim income and expenditure figures
- outline any key areas you are concerned over

Please send this activity report form to:

Freepost RSGX-HEGJ-LJJS  
Arts Council England  
PO Box 4353  
Manchester  
M61 0DQ

Or email it to: [grantsforthearts@artscouncil.org.uk](mailto:grantsforthearts@artscouncil.org.uk)

#### Grants for touring

If your grant has been awarded for touring activity, you must also complete an updated tour schedule, which is included in this form as appendix 1.

## Section A – evaluation

Evaluation is a valuable tool for learning about your activity and how it works. It involves gathering evidence before, during and after a project and using it to make judgments about what happened. The evidence also shows what is happening and why, and should reflect what decision you are making to effectively manage your project.

We are interested in what is going well and what isn't. We are not concerned if your project is not going exactly as planned, but we need to know how you are managing any changes, and what areas may be exceeding your expectations. As long as your activity is still on course to meet the conditions of our grant, this interim evaluation will not affect your payment.

- ✓ 1 **Please summarise how you think your project is progressing. We are particularly interested in any lessons learned and key achievements. You may find it useful to refer back to your original application and discuss how your project is going compared with your expectations. Please use additional sheets if needed.**

The sculptural work 'Just wait for me' remains on course for completion in September 2012. The following phases have take place:

### Stakeholder meetings

9 May Stakeholder meeting @ Central Park Cricket Club

19 June Stakeholder meeting @ Studio

12 July next Stakeholder meeting @ Studio

### School workshops

Weatherhead High School – completed (sessions 18, 25, June, 2 July)

Oldershaw – rescheduled for September

St. Mary's – completed (19, 27 June)

Additional visit to artist's studio by 25 St. Mary's students (19 June)

### Sculpture

8 May Scale model created and delivered to Foundry

23 May armature welded and delivered to studio

12 July casting and fabrication of two figures begin

### Summary

I am extremely pleased with the progress made on the first two figures and the level of engagement by young people at all five school workshops. Designs developed by young people to be submitted to Wirral MBC for consideration in wider landscaping programme. Designs selected for use on sculptural plinth. Three more workshops planned for the Youth Hub during Summer Holidays. Project blog under construction. Meeting with Director of Liverpool Biennial to keep updated.

### Funding

Friends of Everyone's Café commit £1,000

Central Park Partnership commit £1,000

MIRIAD, MMU commit £6,300 to free me up from teaching time

WBC considering commitment of £9,500

This slight delay from WBC has caused some concern within the Stakeholders Group but we remain positive that WBC will honour its

commitment, once some contractual logistics have been resolved. This is partly due to delays on their overall redevelopment of Central Park.

## Section B – statement of income and expenditure

In this section we ask for a summary of the income and expenditure of your activity **to date**.

Please show the budget from your application form (in the column titled 'original'), along with any agreed revised budget (in the column titled 'revised') after the grant was offered to you.

You should explain any significant differences between the actual figures and the budget figures by using the notes column. Assign a letter to the note in the column, then type the same letter and your explanation in the notes box underneath the totals.

The budget categories should be the same as those used in the application form. You may wish to refer to the guidance included in the Grants for the arts application pack.

If you cannot provide enough details on the form, please use it as a summary and provide the details on a separate sheet or sheets, using the same headings. This may be necessary for:

- activities lasting a number of years
- some touring activities
- building projects
- grants for buying several items of equipment

Unless we have asked you for them, please do not send original or photocopies of invoices for goods or services you have purchased for your activity. Remember, you must keep these documents safe as we may ask for them at a later stage. You are responsible for getting your own financial and legal advice. This includes getting appropriate financial advice on your tax status as a result of receiving a grant from us. This is a complicated area and you will need to speak to your own tax office if you have any questions about this. For information about taxes, contact HM Revenue and Customs (HMRC) through their website at [www.hmrc.gov.uk](http://www.hmrc.gov.uk)

### Specific requirements

#### VAT

If you are registered for VAT, your expenditure figures should not include VAT that you can claim back. If you are not registered for VAT, your figures should include VAT. You may need to get advice from your own accountant or the relevant tax office. For information about VAT and other taxes, contact HM Revenue and Customs (HMRC) through their website at [www.hmrc.gov.uk](http://www.hmrc.gov.uk)

### Income for this activity

Earned income (please give details)	Income: original £	Income: to date £	Income Notes (a) (b) (c) etc
<b>Subtotal 1</b>	£	£	

Local authority (please give details)	Income: original £	Income: to date £	Income Notes (a) (b) (c) etc
Wirral MBC	10,000	0	(a)
<b>Subtotal 2</b>	£10,000	£0	

Other public (please give details)	Income: original	Income: to date	Income Notes (a) (b) (c) etc

	£	£	
<b>Subtotal 3</b>	£	£	

<b>Private (please give details)</b>	<b>Income: original £</b>	<b>Income: to date £</b>	<b>Income Notes (a) (b) (c) etc</b>
MMU Research grant towards casting costs	3,000	6,332	(b)
<b>Subtotal 4</b>	<b>£3,000</b>	<b>£6,332</b>	

<b>Support in kind for your activity (please give details)</b>	<b>Income: original £</b>	<b>Income: to date £</b>	<b>Income Notes (a) (b) (c) etc</b>
Brigitte Jurack, waived artist's fee, 56 days @ £150/dy	10,080	4,650	
Brigitte Jurack, waived studio costs, 3 months at £ 210/mth	630	420	
Wirral MBC	5,000	0	
Friends of Central Park, uses of venues	200	100	
Brigitte Jurack, provision of	336	194	

workshop materials (clay)			
MMU - firing costs for model figures	180	180	
Wirral MBC - production of permanent sign for sculpture	300	0	
<b>Subtotal 5</b>	<b>£ 16,726</b>	<b>£5,544</b>	

✓ <b>Total income from other sources (add subtotals 1- 5)</b> (A)	£ 29,726	£ 11,876	
✓ <b>Arts Council grant for this activity</b> (B)	£18,500	£ 9,250	
✓ <b>Total income (A) + (B)</b> (C)	£48,226	£ 21,126	

**Income notes**



**You should provide an explanation for any notes. Assign a letter to the note in the column above, then type the same letter here and write your explanation next to it.**

- (a) Wirral Borough Council's redevelopment of Central Park has been delayed but at the Stakeholders Meeting, WBC suggested that they were trying to attain some of the total contribution from a culture budget, as opposed to totally from the insurance money from the former Liscard Hall. These negotiations remain delicate and I may require further support and advice on this matter.
- (b) MIRIAD (MMU) contributed £4,320 towards replacing my teaching hours in order that I may complete sculpture on time, and £1,280 towards workshop and studio assistants
- (c)

### Expenditure for this activity

Value of support in kind (use the subtotals from Support in kind for Income above.)	Expenditure: original £	Expenditure: to date £	Expenditure Notes (a)(b) (c) etc
Subtotal 1	£16,726	£ 5,544	

Artistic expenditure (please give details)	Expenditure: original £	Expenditure: to date £	Expenditure Notes (a) (b) (c) etc
Fee for 2 early-career artists @ £16/hr, 5 day @8 hrs/days: workshops+ publicity design	1280	690	(a)
Fabrication: moulding (Castle Foundry)	5400	1800	
Fabrication: Casting and finishing (Castle Foundry)	21600		
Installation in Central Park (Castle Foundry)	1440		
Evaluation, 2-day session	1000		

--	--	--	--

<b>Subtotal 2</b>	£ 30,620	£	
<b>Organisational and professional development (please give details)</b>	<b>Expenditure: original £</b>	<b>Expenditure: to date £</b>	<b>Expenditure Notes (a) (b) (c) etc</b>
<b>Subtotal 3</b>	£	£	
<b>Marketing and audience development (please give details)</b>	<b>Expenditure: original £</b>	<b>Expenditure: to date £</b>	<b>Expenditure Notes (a) (b) (c) etc</b>
Printing and distribution of leaflets and posters	350		
Semi-permanent sign (Benson Signs)	430		
<b>Subtotal 4</b>	£ 880	£ 0	
<b>Overheads (please give details)</b>	<b>Expenditure: original £</b>	<b>Expenditure: to date £</b>	<b>Expenditure Notes (a) (b) (c) etc</b>

<b>Subtotal 5</b>	£	£	

<b>Assets (please give details)</b>	<b>Expenditure: original £</b>	<b>Expenditure: to date £</b>	<b>Expenditure Notes (a) (b) (c) etc</b>
<b>Subtotal 6</b>	£	£	

<b>Other (please give details)</b>	<b>Expenditure: original £</b>	<b>Expenditure: to date £</b>	<b>Expenditure Notes (a) (b) (c) etc</b>
<b>Subtotal 7</b>	£	£	£

<b>Access costs (project) (please give details)</b>	<b>Expenditure: original £</b>	<b>Expenditure: to date £</b>	<b>Expenditure Notes (a) (b) (c) etc</b>
<b>Subtotal 8</b>	£	£	

<b>Access costs (personal) (please give details)</b>	<b>Expenditure: original £</b>	<b>Expenditure: to date £</b>	<b>Expenditure Notes (a) (b) (c) etc</b>
<b>Subtotal 9</b>	£	£	

<b>✓ Total expenditure (add subtotals 1-9) (D)</b>	£	£	
--	---	---	--

**Expenditure notes**

You should provide an explanation for any notes. Assign a letter to the note in the column above, then type the same letter here and write your explanation next to it.

(a) First instalment on fabrication  
 (b)  
 (c)

**Section C – declaration**

**Data protection and freedom of information**

As a public organisation we have to follow the Data Protection Act 1998 and the Freedom of Information Act 2000. We have a data protection policy, which is available from our website at [www.artscouncil.org.uk](http://www.artscouncil.org.uk)

Under the Freedom of Information Act, we may have to provide information about your grant to a member of the public if they ask for them under the Act. However, we will not release those parts of your information covered by one or more of the exemptions under the Act. For information on the exemptions and freedom of information generally, please visit [www.foi.gov.uk](http://www.foi.gov.uk)

We consider that the information you give us in section B and in appendix 1 will not be protected by any exemptions and therefore we would release it if a member of the public asks for it.

However, the information you give us in section A could possibly be covered by exemptions if it is sensitive or confidential. If you consider some or all of this information to be confidential, please mark the box below and specify what parts you think are confidential and why.

Mark this box if you want us to treat some or all of the information in section A as confidential. You must tell us what the information is that you think is confidential and give us your reasons below.

---

---

---

---

---

**Checklist for claiming your interim payment**

Before you send in this interim report and claim your interim payment, please check the following:

Have you filled in section A and B

Have you met any payment conditions attached to your interim payment?

If your activity was touring, have you completed the updated tour schedule in appendix 1?

Have you signed the declaration below?

Have you kept a copy of this report for your own reference?

Please remember to sign and date this form below. Individuals should use the section below and organisations should use the section on the next page. If you are submitting this form electronically, please ensure you fill in your name. A signature is not required.

✓ **Individuals**

I confirm that, as far as I know, the information in this interim activity report form is true and correct, and that I have complied with the standard conditions and all payment conditions attached to the grant.

**Your signature**



**Name (Use CAPITAL LETTERS)**

BRIGITTE JURACK

	<b>Day</b>	<b>/</b>	<b>Month</b>	<b>/</b>	<b>Year</b>
Date	09	/	07	/	2012





## Grants for the arts - individuals and organisations

### Introduction

#### Details summary

Applicant:	Brigitte Jurack
Activity name:	Just Wait for Me
Unique reference number (URN):	18949125
Arts Council regional office:	North West

### Section A - evaluation

#### Evaluation

Evaluation is a valuable tool for learning about your activity and how it works. It involves gathering evidence before, during and after a project and using it to make judgements about what happened. The evidence also shows what happened and why, and what effect it had. Evaluation can help you improve what you are doing during a project and what you might do next time.

Evaluation helps us understand your work and the difference our grant made. We are interested in what went well and what didn't. You do not need to prove that you were successful. As long as your activity has met the conditions of our grant, this evaluation will not affect your final payment.

**1. Please summarise how you think your project went. We are particularly interested in any lessons learned and key achievements. You may find it useful to refer back to your original application and discuss how your project went compared with your expectations.**

If you have produced a self-evaluation report which you wish to share with us, please attach it with this form using the button below. However, please give us your main points below.

Please find attached full evaluation undertaken by Naomi Horlock. Her main findings were matched against the following aims:

- working with young people and involving them in the project
- shaping and beautifying the local environment through art
- providing a unique and high quality artwork
- involving other park users in the art project as part of the general environmental upgrade of the park
- improving the image of the park and the people who use it
- developing constructive relationships between WMBC, the various project partners and the artist
- creating a positive, celebratory image of young people which becomes a focal point on the former Liscard Hall site

Horlock introduced her report with 'Overall there has been an extremely positive response to the public art commission from all sectors of the community that were interviewed. Those desired outcomes which have been evaluated so far seem to have been achieved, together with as some additional benefits that had not originally been anticipated.'

In particular, she praises the engagement with young people and the collaborations between various parties during the development of the project.

Word limit 2000

## Section B - your activity

### Your activity

This section gives us statistical information about your activity: where it happened, who was involved and the outcomes. Edit only information which is different from the original application and supply us as accurate figures as you can.

#### 2. Where did this activity take place?

Non-touring activity

Please **delete** any locations which did not happen and **add** any new locations. Select 'Edit' at the end of each row for touring activities and enter the additional information required. For guidance on the information you need to supply for touring applications please go to 'touring schedule guidance'.

### Touring details

If your activity wasn't touring, please answer the following question.

Did your activity happen in a specific place (or places)?

Yes

### Touring details

#### a) Your activity happened in a specific place (or places)

If your activity happened in a particular place, please give us the address and postcode of where most of your activity took place.

### Location details

Name	Postcode	Local authority
Central Park, Liscard, Wirral	CH44 0AB	Wirral

## People who benefit from your activity

### Who was involved?

#### 3. How many people do you estimate benefited from the activity?

Please give an estimate for your activity. Edit only information which is different from the original application.

'Participants' means people doing the activity, including education workshops. 'Audience' includes people going to an exhibition or performance, and people getting access to work that is printed, recorded, broadcast or available online.

This activity	Number
Artists	3
Participants	30
Audience (live)	30000
Audience (broadcast, online, writing)	5000
Total	35033

#### 4. What are the age ranges of the people who benefited from your activity?

Selected age ranges

Please tick all relevant boxes:

- |  |  |
|--|--|
| <input type="checkbox"/> Children under five                   | <input checked="" type="checkbox"/> Young people aged 20 to 24 |
| <input type="checkbox"/> Children aged five to 11              | <input checked="" type="checkbox"/> Adults aged 25 to 64       |
| <input checked="" type="checkbox"/> Young people aged 12 to 15 | <input checked="" type="checkbox"/> Adults aged 65 and over    |
| <input checked="" type="checkbox"/> Young people aged 16 to 19 |  |

**5. Was your activity directed at, or particularly relevant to, any of the following groups of people?**

Tick all relevant boxes:

- |   |  |
|---|--|
| <input type="checkbox"/> Disabled or deaf people              | <input type="checkbox"/> Chinese   |
| <input type="checkbox"/> People at risk of 'social exclusion' | <input type="checkbox"/> Any other ethnic group  |
| <input type="checkbox"/> Asian or Asian British               |  |
| <input type="checkbox"/> Black or Black British               | <input checked="" type="checkbox"/> Not specifically directed at any of the above groups |

**6. Please give details of the results of your activity.** Enter '0' (zero) in any field which is not relevant to your activity.

Number of performance or exhibition days

Number of new products or commissions

Period of employment for artists (in days)

Number of sessions for education, training or participation.

**Beneficiaries notes**

Please explain any significant differences between the actual figures and those you entered on your application.

**Section C - statement of income and expenditure**

**Statement of income and expenditure**

**Please read this carefully before completing this section.**

In this section we ask for a summary of the income and expenditure of your activity. This should be for the total cost of the activity we agreed to support.

The budget from your original application is pre-populated in the column titled 'original'. You must enter all actual figures in the column titled 'actual' and add any new budget lines if necessary. Explain any significant differences between the actual figures and the original figures by using the notes box under the table. Clearly indicate what section you are referring to by using the relevant budget heading against each note entered. You may wish to refer to the guidance 'Filling in your budget' from the Grants for the arts application.

If you received a revised offer or if you have agreed an interim revised budget with us differing from the original requested amount you will also need to update the original figures with those you agreed with us, see guidance.

If you cannot provide enough details in the box, please use it as a summary and attach the details clearly titled in the supporting evidence section. This may be necessary for:

- activities lasting a number of years
- some touring activities
- building projects
- grants for buying several items of equipment

For further guidance relating to invoices, tax status, VAT and Grants over £50,000 click here.

## Income for your activity

Arts Council grant applied for	£18,500
Actual Arts Council grant	£18,500

Select 'Edit' at the end of each row to provide us with the actual amounts for each budget line. Click 'Add Income line' to add any additional sources of income.

## Income for this activity

Income heading	Description	Income original £	Income actual £
Earned income			
Local authority funding	Wirral	£10,000	£9,500
Other public funding	Friends of Central Park		£1,000
Private income	MMU Research grant towards casting costs	£3,000	£2,211
Private income	MMU Research Grant to cover costs of Early Career Artists (Graduate Teaching Assistants)		£1,280
<b>Income total</b>		<b>£31,500</b>	<b>£32,491</b>

### Income notes

You should explain any differences between the actual figures and the original budget figures in this space using the relevant budget heading.

Wirral MBC awarded £9,500 rather than £10,000 as they paid for the landscaping and plinths separately

## Support in kind

### Support in kind for your activity

Select 'Edit' at the end of each row to provide us with the actual amounts for each budget line. Click 'Add support line' to add any additional sources of support.

Description	Income original £	Income actual £
Brigitte Jurack, waived artist's fee, 56 days @ £150/dy	£10,080	£10,080
Brigitte Jurack, waived studio costs, 3 months at £ 210/mth	£630	£630
Wirral MBC	£5,000	£6,000
Friends of Central Park, uses of venues	£200	£200
Brigitte Jurack, provision of workshop materials (clay)	£336	£400
MMU - firing costs for model figures	£180	£200
Wirral MBC - production of permanent sign for sculpture	£300	
MMU support for replacement teaching hours for B. Jurack		£4,320
	£16,726	£21,830

### Support in kind notes

You should explain any differences between the actual figures and the original budget figures in this space using the relevant budget heading.

Wirral MBC provided £5000 in the form landscaping, plinths and an interpretation panel that will replace the 'permanent sign' listed above

## Activity expenditure

### Expenditure for this activity

Select 'Edit' at the end of each row to provide us with the actual amounts for each budget line. Click 'Add spending line' to add any additional items of expenditure.

Expenditure heading	Description	Expenditure original £	Expenditure actual £
Artistic spending	Fee for 2 early-career artists @ £16/hr, 5 day @8 hrs/days: workshops+ publicity design	£1,280	£1,280
Artistic spending	Fabrication: moulding (Castle Foundry)	£5,400	
Artistic spending	Fabrication: Casting and finishing (Castle Foundry)	£21,600	
Artistic spending	Installation in Central Park (Castle Foundry)	£1,440	
Artistic spending	Evaluation, 2-day session	£1,000	
Artistic spending	Fabrication: sculptural materials incl. paint, rubber, Jesmonite		£1,034
Artistic spending	Evaluation, fee to Naomi Horlock		£500
Artistic spending	Travel expenses for studio assistants		£155
Artistic spending	Fabrication: Castle Foundry mould, armature, fabrication and installation of two figures		£26,634
Artistic spending	Fabrication and installation of third figure		£2,500
Making your performance accessible			
Developing your organisation and people			
Marketing and developing audiences	Printing and distribution of leaflets and posters	£350	£359
Marketing and developing audiences	Semi-permanent sign (Benson Signs)	£430	
Marketing and developing audiences	Brass plaque for sculpture (Labels'n'signs)		£120
Overheads			
Assets - equipment, instruments and vehicles			
Assets - buildings for arts use			
Other			
If you are disabled or Deaf, additional access or support cost you need to manage the activity			
<b>Expenditure total</b>		<b>£31,500</b>	<b>£32,582</b>

#### Expenditure notes

You should explain any differences between the actual figures and the original budget figures in this space using the relevant budget heading.

n/a



## Section D - how did we do?

### How did we do?

Your feedback is very important to us. The information you provide is reviewed as part of our internal quality assurance process. It helps inform us how we are managing the Grants for the arts programme and the service we provide.

Thinking about the grant you have received from us, how did we:

**a) Explain about eligibility to apply for funding?**

Very well

**b) Explain the application process?**

Very well

**c) Manage your application for funding?**

Very well

**d) Respond when you contacted us for advice or information?**

Very well

**Are there any other comments you would like to make?**

## Section E - declaration

### Data protection and freedom of information

As a public organisation we have to follow the Data Protection Act 1998 and the Freedom of Information Act 2000. We have a data protection policy, which is available from our website at [www.artscouncil.org.uk](http://www.artscouncil.org.uk).

Under the Freedom of Information Act, we may have to provide information about your grant to a member of the public if they ask for them under the Act. However, we will not release those parts of your information covered by one or more of the exemptions under the Act. For information on the exemptions and freedom of information generally, please visit [www.foi.gov.uk](http://www.foi.gov.uk).

We also have an information sheet about freedom of information. You must read the '*How we treat your application under the Freedom of Information Act*' section of 'How to apply' before you sign your application.

We consider that the information you give us in sections B and D will not be protected by any exemptions and therefore we would release it if a member of the public asks for it.

However, the information you give us in sections A and C could possibly be covered by exemptions if it is sensitive or confidential. If you consider some or all of this information to be confidential, please mark the box below and specify what parts you think are confidential and why.

Mark this box if you want us to treat some or all of the information in sections A and C as confidential.

### Checklist for claiming your final payment

Before you send in this activity report and claim your final payment, please check the following:

- Have you met all payment conditions attached to your final payment?
- If your grant was for more than £50,000, and you are not a regularly funded organisation, has the statement of income and expenditure been certified by an independent accountant? Please attach a letter from an independent accountant who has certified that your income and expenditure are true and accurate in the supporting documents section.
- Have you checked your bank details have not changed in the duration of this grant without notifying us?

### Individuals

**I confirm that, as far as I know, the information in this activity report form is true and correct, and that I have complied with the standard conditions and all payment conditions attached to the grant.**

Name	BRIGITTE JURACK
Date	31/01/2013

### Supporting evidence

Please attach any supporting evidence relating to your activity along with any documents required for conditions linked to your final payment. These must not exceed 10Mb.

Some examples include:

1. images of the activity
2. views on the quality of your work by other people, such as audiences, people taking part, readers, critics or other artists
3. links to other sources of information about your work, such as websites
4. a small sample of or images of the activity

**Attachments and links**

<b>Description</b>	<b>Link to open / download</b>	<b>File Size (MB)</b>
Project tumblr site	<a href="http://brigittejurack.tumblr.com/">http://brigittejurack.tumblr.com/</a>	
Just Wait For Me installed	JustWaitForMe1.jpg	0.4
Just Wait For Me installed	JustWaitForMe2.jpg	0.7
Just Wait For Me installed	JustWaitForMe3.jpg	0.6
Just Wait For Me installed	JustWaitForMe4.jpg	0.4
<b>Total</b>		<b>2.1</b>

# Evaluation Report on 'Just Wait For Me' Public Art Commission

## What is Public Art?

The spectrum of artistic practice represented by the term public art encompasses art commissioned as a response to the notion of place, art commissioned as part of the designed environment and process-based artistic practice that does not rely on the production of an art object. When searching for a definition of public art it is most helpful to regard public art as a process of engaging artists' creative ideas in the public realm

ixia, Public Art Think Tank, March 2010

## Background

Central Park lies in the heart of Liscard, Wallasey, in the borough of Wirral. Surrounded largely by terraced housing, it became a community park around Liscard Hall (1832), having been formerly a merchant's house. The building was more recently used as an Art School but suffered an arson attack in 2008 and subsequently the remains were removed.

As part of the Council's commitment to the Park, an upgrading of the local play area and a fitness trail was planned, along with some form of art intervention for a landscaped area where Liscard Hall once stood. The Wallasey Central Park Partnership and Wirral Metropolitan Borough Council undertook initial consultation with local young people in 2010.

From March 2011, lead artist Brigitte Jurack ran creative workshops for young people at the local Youth Hub. These workshops focused on designing a place that would serve both as a focal point and somewhere to "hang out" for youngsters in Central Park.

As a result of these consultations and in conjunction with additional input from the local community, Wirral MBC and the Wallasey Central Park Partnership, a proposal was developed for a permanent sculptural work entitled 'Just wait for me'.

This installation aimed to use sculpture to portray young people in a celebratory manner and provide a focal point for performative display and play.

## Desired Outcomes

As part of the consultations that Jurack undertook with both funders and the community a series of objectives for the project were established, which were as follows:

- working with young people and involving them in the project
- shaping and beautifying the local environment through art
- providing a unique and high quality artwork
- involving other park users in the art project as part of the general environmental upgrade of the park
- improving the image of the park and the people who use it
- developing constructive relationships between WMBC, the various project partners and the artist
- creating a positive, celebratory image of young people which becomes a focal point on the former Liscard Hall site

The scope of this report is to determine to what degree these desired outcomes have been achieved and to provide useful and relevant feedback for all interested parties. The report's focus is very heavily on the experiences of those involved in the project to date and therefore a qualitative approach has been adopted (see 'Methodology', p. 6)

*A useful evaluation will be founded on specific questions arising from programme and project management as well as funder requirements. Simply asking, 'What are the outcomes?' or even 'What works?' may be misleading. We need to make sure that we ask questions that require another level of response, such as: 'What parts worked?' 'What were the key elements of the service?' 'Who did it work for?' 'In what contexts did it work?' 'What else happened?'*

Dr Jean Ellis, Charities Evaluation Services, page 4 of pdf leaflet:

<http://www.ces-vol.org.uk/Resources/CharitiesEvaluationServices/Documents/Measuring%20social%20value%20avoiding%20a%20methodological%20straightjacket.pdf>



## Summary of Findings

Overall there has been an extremely positive response to the public art commission from all sectors of the community that were interviewed. Those desired outcomes which have been evaluated so far seem to have been achieved, together with as some additional benefits that had not originally been anticipated.

### WORKING WITH YOUNG PEOPLE AND INVOLVING THEM IN THE PROJECT

Schools/teachers – positive feedback:

- pupils became involved in the project through a mixture of artist's studio visits and in-school workshops
- the artist showed exceptional aptitude for working and developing relationships within educational environments
- school art students thoroughly enjoyed their participation in the project
- the students learnt new skills, both practical and intellectual
  - students worked with materials previously unknown to them
  - students learnt about creativity and interpretation; how to find inspiration and generate ideas
- interaction with a professional practising artist/academic proved invaluable in terms of widening students' horizons and even potential career choices
- older children benefited most from the experience
- teachers keen to work with the artist again in the future

Schools/teachers – future recommendations:

- longer lead-time for projects with schools would enable more ambitious projects to be integrated within the schools' agenda
- teachers would have liked pupils to have something to put in their portfolios about the project and for it to be able to contribute in some way to their GCSE's in Art
- teachers very much thinking about it in terms of what it can do for them/their students to contribute to their examination results and career options; need to look more closely at what it actually contributed to a) their understanding of public art, and b) their interest/view/understanding of sculpture as an artistic form and c) the wider range of career options open to someone with artistic skills

### SHAPING AND BEAUTIFYING THE LOCAL ENVIRONMENT THROUGH ART

- the sculpture contributed significantly to the overall ambience of the park's new

- performance area and gave encouragement to practitioners of other art forms
- members of the public were suitably impressed
- other groups have yet to be questioned/will be assessed in the summer

#### PROVIDING A UNIQUE AND HIGH QUALITY ARTWORK

- teachers and pupils heaped praise onto the sculptures and were extremely enthusiastic about the final product
- the Wallasey Central Park Group also gave the finished object a glowing review
- some park users did not identify with the sculptures and this affected their view
- other groups have yet to be questioned/will be assessed in the summer

#### INVOLVING OTHER PARK USERS IN THE ART PROJECT AS PART OF THE GENERAL ENVIRONMENTAL UPGRADE OF THE PARK

- it became readily apparent for all groups that involvement helped to generate goodwill, interest, understanding and appreciation for the artwork
- moreover, there is evidence to suggest that increased involvement correlates strongly with an increased level of appreciation of the artwork, and this is perhaps something that will become more evident through the future quantitative assessment

#### IMPROVING THE IMAGE OF THE PARK AND THE PEOPLE WHO USE IT

- there was widespread agreement that the sculptures had improved the image of the park
- whilst some expressed nervousness about potential damage, others believed that the level of involvement of the young people locally would lead to a sense of ownership of the artwork and prevent this from happening
- to be further assessed in the summer

#### DEVELOPING CONSTRUCTIVE RELATIONSHIPS BETWEEN WMBC, THE VARIOUS PROJECT PARTNERS AND THE ARTIST

- all groups involved were positive but particularly the schools and it is obvious that the artist's professional understanding of education played a big part in this
- although very good relationship had been developed with the schools, following-up on projects was always going to be difficult due to the rapidly changing nature of school life

- WMBC's remit to serve the wider community had been adequately met by the project and they were particularly pleased with the efforts made to involve the young people, who can often be a difficult target group to engage successfully
- timing and funding was judged to be fortuitous from the WMBC point of view and there are lessons to be learnt on both sides (council and artist) about how to communicate when opportunities for similar projects in public spaces may become available
- similarly with the Wallasey Central Park Partnership, the joint venture had been judged a success but the approach from the artist had been completely opportunistic and it was not clear whether funding a sculpture would have been on their list of "things to do" for the park's renovation had she not come along when she did

#### CREATING A POSITIVE, CELEBRATORY IMAGE OF YOUNG PEOPLE WHICH BECOMES A FOCAL POINT ON THE FORMER LISCARD HALL SITE

- in one sense, only time will tell and that is why this topic area will be explored more fully in the planned future quantitative assessment
- the WMBC representative was the only member of the overall project team other than the artist herself to have direct experience of installing public art and significantly the only person to *spontaneously* comment on the huge significance of having large statues of young people featuring so prominently in a public park
- having a positive, celebratory image is important in changing not only other people's perceptions of the young people in the park but also the youngsters' self-perceptions and the choices they make about their own behaviour in the light of that

## Methodology

### QUALITATIVE ASSESSMENT

A series of relaxed and fairly informal qualitative depth interviews and group discussions were conducted by Naomi Horlock. Naomi is an arts professional with over twenty years' experience of arts education gained in gallery and community settings including Tate Liverpool, Lancashire Youth Offending Team, Open Eye Gallery, the Williamson Art Gallery and National Museums Liverpool. Since 2009 she has been developing VidA Creative Learning, an arts education initiative that trains and mentors new and emerging practitioners to work with children, young people and families. She is currently Learning and Participation Curator at MOSTYN, Llandudno.

These interviews covered all the objectives listed under 'Desired Outcomes' (p.2) but were focused primarily on people's experiences relating to the following outcomes:

- working with young people and involving them in the project
- developing constructive relationships between WMBC, the various project partners and the artist

All sessions were recorded digitally and full transcriptions are available on request (see Appendix Two for selected transcription of an interview with a teacher).

### QUANTITATIVE ASSESSMENT

Whilst all the desired outcomes were covered to a degree within the qualitative assessment, due to the nature of the information required, and the seasonality of usage of the park, it is recommended that a quantitative approach also should be undertaken during the summer months. This would help to gauge attitudes to the artwork more fully by allowing time for the sculptures to reach a wider audience and also, therefore, to canvass public opinion more widely.

A sample questionnaire is attached in Appendix Two at the back of the report. Building on work that has already been undertaken by The Wallasey Central Park Group looking at park usage, this survey would cover the following objectives relating in more depth by covering park users' usage of the park and opinions and attitudes towards the 'Just Wait For Me' sculptures:

- shaping and beautifying the local environment through art
- providing a unique and high quality artwork
- involving other park users in the art project as part of the general environmental upgrade of the park
- improving the image of the park and the people who use it

- creating a positive, celebratory image of young people which becomes a focal point on the former Liscard Hall site

## Sampling

### QUALITATIVE

Representatives from all major groups involved were interviewed. These included:

Two senior teachers from local secondary schools where pupils had been taken part in the project

Three Year 10 pupils from the school whose ideas had been instrumental in the project's development

One Year 13 pupil

Two members of the Wallasey Central Park Group and local cricket club

A local resident mother and park user/dancer

A local resident and dancer

A senior project member from Wirral Metropolitan Borough Council

Three local councillors

The artist

### QUANTITATIVE

It is recommended that a representative sample should be drawn from park users (both local residents and visitors) using basic demographic data such as age and sex, together with postcode and socio-economic profiling if available, and if respondents are willing to disclose this information.

Face-to-face interviews should be conducted throughout different times of the day and week in order to capture as wide a range of park users as possible. For statistical robustness, a minimum of 200 interviews is recommended.



## Findings for the Qualitative Assessment

### Working with young people and involving them in the project

Within an educational setting this objective seems to have been achieved admirably. Two of the key groups to become involved were groups of students from local secondary schools in Wallasey. In total nearly 40 young people from these schools participated in the project. In addition around 35 young people from the Hub took part.

One teacher illustrated how the artist worked with these young people and involved them, firstly through a visit to the artist's studio and secondly through a workshop in the school:

*[At the studio ...]*

*"Brigitte talked about what the project was, showed us some of her work and explained ... explained first of all really how she'd come about in her work and I asked her to talk to us a little bit about being an artist and what it was like for her and where she got her work just to give them an insight career-wise and then she did that, and that was lovely, and then she showed them some of her work, and she talked through the project proposal, and showed them some of the little cats that she'd done, and then explained that she was going to come in and work with them and do photographs, and then work with them on a workshop."*

*[At the school .. ]*

*"Brigitte talked in the workshop about figures and poses and like almost like things that we just do naturally we see in kind of classical sculpture as well and she talked to them a little bit about that and then she just said to them ... just work in sort of pairs, work in group work and trying to show friendship, and different poses about friendship and dynamics ... "*

When asked if she recalled her pupils' comments at the time about the workshops in her school, another teacher commented:

*"I remember them enjoying them. I remember them being really relaxed; we all sat there chatting about things ... I just remember it being a really nice experience and the girls enjoying the sessions 'cause making's so lovely and it was very detailed and some of them really got into it."*

The pupils themselves found the workshop experience hugely beneficial, especially when it came to learning about creativity and interpretation:

*"It was good. It was easier than, just like, having to come up with any things. If you've got a theme then it's easier than having to just randomly think."*

*"[We] made wax sculptures ... looked at friendship; we were all in one group, ours [theme] was friendship and others had, like, sadness, there was a mixture"*

*"We made piggy-back sculptures out of the wire and then we had to put plasticine round them ... did different themes, most around piggy-back and friendship. We had to interpret them in different ways."*

They described how the themed workshops led to their developing inspiration for the first statue:

*"We took pictures of each other ... "*

*"We were talking about friends, taking pictures, giving each other piggy backs."*

The teachers were very positive about the new opportunities that a visit to an artist's studio had offered not just in terms of their intellectual development but also at a practical level, learning to work with new materials, for example:

*"The workshop was brilliant because what they did was, they worked with this material, I think .. Brigitte'll know, I think it's like a bees wax, this yellowy type of wax that, erm, the students **really** enjoyed working with. And what they liked about it was, was from start to finish, e.g. getting the idea, the stuff was malleable enough to have a finished product by the end of their session. I think they kind of liked that, you know."*

Moreover, it became apparent that for at least one student, the opportunity to have contact with a practising artist who was also involved in the field of higher education had opened up her ideas about a new new career:

*"The feedback that I got from the sixth formers was that they found her really interesting to talk to, as I say, she really inspired one of the students who's in my form, erm, was really pleased with her work and it gave her loads of confidence and Brigitte said to her 'Oh, well, you've obviously got an ability at this', and she talked to her about doing architectural sculpture, and [girl's name] had never thought about that before, and now, as I say, she's applying to do architecture. And from that, I got her onto an architecture course ... placed in John Moore's University and now that's what she wants to do. It actually gave her a career input, really, that she would just never have considered before at all. And that is excellent."*

When this particular student was interviewed, she described how she "loved" the visit to the studio and how she "didn't expect the artists to be so local". She had really enjoyed having the opportunity to work in 3D as this had not really been a feature of what was available at school. For young people who were both artistic and had a high level of spatial awareness, the opportunity to work with sculpture was a rare and exciting one. The experience also raised awareness of how artists work.

The benefits for the class as a whole of interacting with someone at Jurack's level were apparent as well:

*"And I think for them, having a practising artist, who's obviously working internationally, knows what she's talking about, is at university herself, lecturing, I think it gives them real confidence if someone like that is saying to them, you know,*

*'Have you considered this? ... You're really good at that.'*"

## **Shaping and beautifying the local environment through art**

Already it seems to be the case that the sculptures are inspiring other artists and art forms to use the park as a number of local resident park visitors involved in dance performance were expressing a keen interest in using the nearby performance space:

*"I was wanting to find out, see, who we could talk to, to see if we could kind of do something with the young people in response to [the artwork] ... I wonder whether we could work with some of the same people from the same schools or, Brigitte told me about the Young People's Hub that she worked with ...It's great to have come and seen it."*

*"I think it's a great idea, it's a great way to use the space. I think it'd be fun, you know, like, weather permitting, erm, to do something outdoors. It's different. It's not the norm but it's a great way to use the space .... There's some really great changes going on."*

Even random members of the public who had not been involved in the project at all were keen to express their admiration for it, as the representative for WMBC recounted:

*"I think people can be quite negative a lot of the time but it's only when you start explaining things to them they think 'Oh, well, yeah, that is quite good' ... even myself, when I was on site one day I seen two elderly people coming toward me and I thought they were going to be really negative as they were saying 'Are you responsible for this?' sort of thing and I was like 'Oh, here we go ..', sort of thing and I said 'Oh well the artist has been working with young people to do this and we've been landscaping the site' and she said 'Oh no, I think it's wonderful' and I said 'Well the artist'll be here later if you want to come 'cause they're doing the opening ...' and she said 'Oh no, I just wanted to tell someone how marvellous it is ..'"*

A local councillor also described how a father had commented on this being "what the park is all about."

## Providing a unique and high quality art work

At the time of interviewing, pupils who had taken part in the project and been responsible for generating the ideas for the sculptures had not yet been able to see them (the second sculpture, 'Sitting On The Wall', was still in production). When shown photographs of the first work, 'Just Wait For Me', on a computer, the young people and their teacher were impressed:

*"Oh wow ... "*

*"That's fabulous!"*

*"So cool ... "*

*"It's really good."*

*"I think it's really beautiful."*

*"I think it's wonderful. I think it's absolutely beautiful, and, I think it represents exactly what she [the artist] was trying to do. I think the girls will absolutely love it."*

Other park users, such as a member of the Wallasey Central Park Group, were also enthusiastic about the finished product:

*"I think it's very good. I mean, as I say, it's involved the schools locally and Brigitte's obviously quite heavily influenced by what all the students have wanted and I think all their ideas have been put into the statues so I think they've come out really well."*

However, there is obviously a subjective element to the appreciation of any art and some users were less impressed. The artist herself referred to being told by a friend about "some dog walkers who absolutely hate it". However, as she points out,

*"These dog walkers are old people ... and deep down, they get it, because we haven't talked about the fact that these are two hoodies, and they are standing there in prime position now, so that these sixty-five year old dog walkers are pretty much not liking it, also has I think has something to do with the very fact of what the sculpture is about."*

In contrast, a local councillor saw the sculpture as "an innovative piece of art that contrasts brilliantly with the war memorial."



## **Involving other park users in the art project as part of the general environmental upgrade of the park**

It appears that the project has benefited from being part of a general overhaul of the park, with a number of different groups being involved, which has helped to create a lot of goodwill, interest and understanding:

*"I'm sort of biased by the fact that I'm involved with the park's partnership so obviously I was quite enthusiastic when [the partnership president] came along and said that Brigitte was interested in doing something in the park .... The Park Partnership's quite a good steering group because you've got quite a few representatives of all the user groups here, so at any one time there's probably about 15 to 20 people come along to the meetings and it's been quite positive that people have seen the ideas that Brigitte was putting forward. At one of the meetings she actually gave a presentation of what was happening ... "*

This aspect was also of paramount importance to WMBC:

*"I think there's been other projects happening in the park and I think people have suddenly seen that there's been things happening ....*

*I think it's been a really good project for me this year ... and I think this has been quite a good, uplifting project to see; other people's involvement, you know, get the wider aspect ..."*

Whilst interviewing all the various groups involved, it also became apparent that negative comments were more likely to come from people who had not been involved, and therefore did not understand any of the positive benefits that sculpture and/or public art programmes can have (such as social cohesion and educational opportunities within the community). As one member of the park user group commented:

*"[Local people will react] ... I think, generally positively but I mean there were a few comments toady from people who say 'Well the council's cutting money etc. and people could lose jobs and why are we doing this?' but everything moves forward and I think that what's happened here today is part of the road that is the further development of the park."*

The WMBC representative was also equally aware of this issue, having worked on several public art projects before. Talking about the likely responses of general members of the public who have not been involved in projects and are randomly asked for their opinions on the art, the following observation was offered:

*"That's really nice that is [to get positive feedback], to get that for a project, 'cause you do tend to get more of the negative people ..."*

## Improve the image of the park and the people who use it

At the opening ceremony for the artwork, one guest spontaneously offered this opinion:

*"I thought it was quite an interesting sculpture. And I think it, you know, it improves the park area. And I think the seating designed round it's really good and the fact that it's a community project can only make it better really ... it does improve the area; it's pretty good."*

Again, talking about the changes effected recently within the park, and the artwork in particular, one local resident mum made the following observations:

*"It's improved since we moved here in 2005, and came to the park but not that much, well I suppose I started coming when I had him [child] really, um, and we've been using the park A LOT since then. He was born in 2009. I've seen a change, obviously with the hall going that was really sad and I didn't know about the history of it and everything at the time, but I was just hoping that at some point someone would come along and revamp it and use it as something that the community could access in some way ... "*

When questioned more specifically about the likely reaction to the new artwork, she also commented:

*"I don't know; I hope it will be really positive, and I hope because the young people [were] involved in developing it that it will be respected, I really do. I just don't know, I just don't know. I really hope that it is respected ... "*

Clearly although the artwork is seen to be contributing to the park's renaissance, there is still some doubt amongst residents as to whether its new image will be enough to stop some of the old, negative behaviour patterns and that is something that only time will be able to tell.

*" I think there is some hope. I was just thinking the other day that visual art is becoming more and more a part of what you expect to see when you're out and about. There's something outside the Ferry Terminal now ... there's loads of stuff all over the place so maybe people are getting more used to seeing it and not trashing it."*

However there were generally more positive comments than negative ones as illustrated by a key member of two of the park's user groups. When asked about his thoughts about the 'Just Wait For Me' sculpture, he said:

*"Well, I think it's great for the park, anything that helps to develop the usage of the park and the presentation, and also involves all ages ... The Liscard Hall site has been derelict for many years but I, as a local person, know it from the '50's as a school of art ... I remember it operating as a school of art ... I can remember it being well-used and a bit of mystique about it ... and it's great to see the sculpture as a natural development of that."*

For the park's steering group, the installation of the artwork represented the final culmination of years of hard work and planning designed to improve the park and encourage renewed use of it:

*"The last few years have been great; we've secured funds, the new sports equipment has gone in, Liscard Hall site's been dealt with and the sculpture's gone in ... and I think that area, next summer, will start to be used."*

From WMBC's point of view, again, a positive change had been achieved with the installation of public art and the involvement of the young people was seen as key to that process:

*"And the numbers of young people that Brigitte's been able to get on board has been great really and their involvement and their creativity. I'm hoping really that through that it will keep them sort of motivated to look after the site and take ownership of the site. We've had no vandalism as far as I'm aware, touch wood ... People can see the amount of involvement that's gone on and the consultation that's been going on over the year or so and hopefully they're all just really positive. I think a lot of people were really pleased to see something happening to the site as well, and that helped."*

## **Developing constructive relationships between WMBC, the various project partners and the artist.**

### Schools

Schools were extremely positive about the experience of working with a practising artist and the way that the relationship had developed. The project got off to a good start in that the artist initially approached them via e-mail with a very specific plan outline of what she intended to do, and the part their students could play in the project:

*"She was really clear, was really interesting, and she had, like, breakdowns of sessions, really organised and I knew exactly what she was going to do and it just seemed really easy from my point of view ... Easy to slot in and clear of the outcomes ... and it's something that they've never done before, so they were learning new skills ... 'Cause usually it's a bit flaky, a lot of the approaches that we get are very soft and as a school, we need to be very clear and she was very clear ... she was very specific, really clear, then she came in for a meeting, that meeting was really positive, I really liked her, really loved where she was coming from ... she had some great ideas ... and we had a very short, concise meeting that was like bang, bang, bang, bang, bang, we need this many students, this many sessions, we'll have it here, I need these things, and I'll organise that and you do that. Brilliant."*

### Considerations for future projects from the schools' perspective

Both teachers who were interviewed expressed an interest in working with the artist again on similar projects and made suggestions for the future. Whilst the artist was commented on extremely favourably for her meticulous organisation and clarity of purpose, one of the key points to come through about working with schools was the necessity to allow plenty of time for preparation. This was felt to be partly down to bureaucracy:

*"Anything less than a month, and really we would have struggled, only 'cause of, really, constraints that the school puts on, you know, not because of ... the students, it's just filling in paperwork for the school really."*

However it was also felt to be down to the sheer number of different things going on in a school at any one time and the general necessity for advance planning:

*"I get contacted a lot by e-mail about projects etc. but we're REALLY busy so there's only certain things we take on."*

The point was made by both schools that whilst they had been given just enough time in this case to organise their participation in the project, their ideal requirement for scheduling activities was a *minimum* of one month's notice.

*"If it had been a week's notice we couldn't have done it, even two weeks is a bit*

*short but a month kind of gives us enough time ... "*

*".. it would've been better to have more notice ... I suppose she thought two or three weeks was enough notice, you know, but it wasn't, it would've been good to have it at the beginning of September 'cause of all the planning before it ...*

Some regret was expressed that the pupils themselves did not have anything within their own portfolios to demonstrate how they had participated and what they had learned. It was felt that this could have made a significant and positive contribution to their GCSE Art 'A' - level assessments.

*"I think if they were going to do anything different it would be .... Maybe they could've had, like, two on the go and kept one, or had something to show for themselves possibly. Maybe, in hindsight, if I would've done it again I would've got their sketchbooks taken down to the studio, got them to sketch some of Brigitte's stuff in there, maybe had a go with the material and done some research on it so the whole process could be more evident for when they get assessed. Selfishly, for them!"*

Linked to this observation was reference to the need for what the interviewer referred to as "top and tailing". In effect this means building in a longer lead-in time for schools in the run up to a project, then trying to build in some kind of strategy for follow-up which accommodates for the busy schedule within day-to-day life at school.

*"Or even if myself and Brigitte, or whoever was running the programme, if we kind of went, 'Ok, if we kind of do it two or three months in advance' we can really, you know, get a decent bit of work out of it."*

However both teachers recognised that in practice, the following-up on such projects was always going to be more the more difficult part. It was noted that the artist had done everything that she could possibly have done to facilitate post-project involvement and that schools admitted that they were simply too busy to carry on giving it their full attention.

*"That's just the way it is. Things just roll so fast that you're on to the next thing, they're in a new year group, it's gone .... And Brigitte, she sent me all the things ... it's not from her not involving me ... I just did not have time, to get the kids sorted, to meet them, to get them letters, to get replies back ... I know it sounds ... but you're kind of on to the next thing and it's really difficult to follow up like that."*

So this was not a reflection on the artist's ability to plan, or to develop constructive relationships. On the contrary, comments from the schools were extremely positive. It was felt that the artist's understanding of the benefits for pupils from such collaborations was well demonstrated and her ability to interact successfully with other education professionals was exemplary.

*"It was a positive, lovely experience [for the pupils] ... there was some really good feedback as well from the art teacher who sat in with us on one of the workshops. She said they were lovely sessions, really well planned, really nice, like, foundation ...*



*she gave them all the context of sculpture, she gave them all the history to sort of, plant the project, if you like ... and they learnt, you know."*

Another consideration for the future that emerged was that schools felt that it was the older (sixth form) students who benefited the most from the project. One teacher noted how the younger students had been either slightly over-awed or felt slightly out of their comfort zone with the whole concept of a studio visit:

*"They were a bit kind of like ... what's it all about? Like, out of their environment ... They lose the willingness to be uninhibited for a couple of years .."*

Wallasey Central Park Partnership

Through undertaking a survey, and through talking with young people, the Park Partnership had already identified a need for an area for young people to hang out and therefore anything that contributed positively to bringing this about was going to be a winner for them:

*"The Park Partnership commissioned a survey about four years ago ... and the overriding message from the young people was 'We want somewhere to meet, to play ... to entertain ..' and that sort of thing."*

It was extremely opportune that the artist approached them when she did in terms of the park's renovation programme. One senior member expressed his views thus:

*"As far as the Park Partnership's concerned, I think generally, everybody's very supportive. There was no question that we were not going to do it and I think the first question was 'How can we help you?' ..and the funding from the partnership was approved with no problem at all."*

Wirral Metropolitan Borough Council

From the WMBC's point of view, the perceived benefits of the collaboration were mostly related to the numbers of different groups within the community that had become involved with the project, in particular the local youngsters:

*"The main thing was the young people's involvement in the process ... I think it was really nice to see them getting involved and getting on board and getting interested, and sort of inspiring them as well; getting them to take ownership of something in the park as well ... if they're trying to get something put in the park, you know, that's when we're normally getting involved with them, if it's a skate park or something like that, a lot of the time that's not always possible because of the finances involved ... so trying to keep them sort of captivated is hard work and because it takes such a long time to get it through from the start of the idea to the completion. It's hard to keep them involved with it for that long period, whereas this, because it was such a good turnaround, and because it got them so motivated, it was a really good, timely project."*

Timing was felt to be crucial to the project's success by WMBC because the artist had begun her preparations just as the council's renovation of the park site had also begun and this was clearly mutually beneficial. Moreover, the [arts council?] funding came through at exactly the right moment to allow for the development phase of the artwork programme, which contributed to bringing so many people within the community on board:

*"It was good that it was so timely really, 'cause it happened in coincidence really, that Brigitte had already started involving young people in the area and we'd just started looking at the site so it all sort of slotted into place ... it was great ...so the timing of it was really good , and also the funding as well; 'cause that doesn't always work out well does it? Even though Brigitte had applied for the funding already sometimes that lead in process is too long ... it was all really funny the way it all just slotted into place and that was great; it's not often that happens!"*

### The Artist

From the artist's perspective, there was an awareness that it is more likely to be council who are on the receiving end of any complaints and negativity due to their remit to serve the public and hence being answerable to a large body of people with a very wide range of opinions. Therefore she felt that it would be interesting to see what the end result would be in terms of possible future collaborations:

*"Would it give [the council representative] enough faith to work again with an artist, if and when the situation arises, I mean maybe not, in the middle of a recession, but sort of in principle, you know ..?"*

In terms of the development of the relationship with WMBC, the artist felt that there had been a progressive accrual of mutual trust and respect that had grown slowly but surely, reaching the stage where they were able to bounce ideas off each other:

*"She actually came to all the meetings, she didn't miss a single one ... she proudly took photographs, and she actually had the idea for these plinths, just being these, like, you know, concrete rings from plumbing and I went with it because I thought it was fabulous, I thought great idea ... only cost £25, you know!"*

The development of the relationship with the "Friends of the Park" (Wallasey Central Park Partnership) came about through the artist's need to find an actual site for a public art proposal as part of her PhD. She described how this led to the initial approach:

*"The original motivation came from my PhD supervisor saying I should be much more specific about a site and then because I knew that this building had gone, I thought well, maybe I should just do something for Central Park ... but when I then met the Friends of the Park, they then told me they had done all the consultation and the plans were in place for those upgrades but everyone was, as usual, really really slow, and that's how I could then manage to jump on the bandwagon, so to*

*... speak."*

Although there had been some resistance to the idea of installing figurative sculpture from one member of the park group initially, this resistance was soon replaced by a more positive approach from others, including a more senior member.

Whilst still in the initial consultation stage with WMBC, the artist describes doing some public consultation with a view to perhaps doing an even larger project:

*"There was this ... consultation thing ... and I had provided these boards, and it was just a general questionnaire and I had all these pictures of great play areas in Europe and I just ask people which was passing by, you know, which would they give a first prize, second prize and third prize ... and people stopped and said yeah, it would be really great, this amazing swing .. but when I then spoke to [WMBC] afterwards because I thought, you know, it would be great if I could do the entire design of this space, you know, it was quite clear that I would never have got there."*

However, this was not to be.

*"I think [WMBC] roughly knew what budget there was and what [WMBC] was planning to do there with the sculpture."*

There had in fact been an original plan for a different kind of sculpture linked to the gateway to the park but when the artist made her proposal it was accepted. This she described as "pure coincidence" and "pure luck" because there had been "no call out for a commission or anything" and hence the whole approach on the artist's part had been completely opportunistic. This is a "bottom-up" approach that is not the norm:

*"Here's a local artist, although of international standing, who's discovered a little niche, so to speak, and a need, and is responding to that, and by pure, freak coincidence ... you know if there hadn't been the building burnt down, and if there hadn't been the insurance money, it wouldn't have happened, but that's life, you know."*

### **Creating a positive, celebratory image of young people which becomes a focal point on the former Liscard Hall site**

Only one interviewee *spontaneously* mentions this and that was the WMBC representative. This may have been because the nature of their role meant that they had previously worked on a variety of projects that included public art in open spaces and therefore had a deeper understanding of the range of purposes that such an artwork can serve:

*"I think it's just that young people are actually represented in the sculpture as well is really unusual so that's nice to see ... and I think it's nice for young people to see as well; that they can be represented in a positive light"*

However, at the park/sculpture opening ceremony two local ladies illustrated the point that negative perceptions of young people do need challenging:

First Lady: *"It's kids playing isn't it? One piggy-backing the other ... [like] that's all they do in the park! Some of them are busy smoking dope and taking drugs and drinking lager!"*

Second Lady: *"That's the perception of all kids do in the park, it isn't necessarily [the case] ..maybe what some teenagers do ..."*

First Lady: *"It does improve the area. It's pretty good."*

## CONCLUSIONS AND RECOMMENDATIONS

At the beginning of this report, a number of objectives, or 'Desired Outcomes' were listed and the evaluation process has attempted to measure how successful the 'Just Wait For Me' sculpture project has been in achieving them.

These objectives had emerged through the artist's consultations with young people. However, in the final analysis they do not represent the only interested party, so this last section of the report will also consider what the wider artistic, social, environmental and economic implications might be and how these relate to other stakeholders' aims, such as the funders and the local community.

### KEY FINDINGS

The key findings of the evaluation relate to the following areas;

- timing
- integration with wider renovation project
- involvement/local engagement
- benefits of participation for young people and schools

#### Timing

All parties involved in the project agreed that the timing had been fortuitous and that this had been down to luck more than planning. Whilst the artist had demonstrated excellent project planning skills, there is still room for some improvement on lead-in times with schools when undertaking future projects.

A recommendation for future action would be to create a retrospective project plan. This could take everyone's lead times into account to see what lessons can be learnt, and how best to manage working with a wide range of organisations and funders with different

### Public Art

"For an artwork to be public, it must invite engagement not only from different groups but also between them. If negotiation between diverse social identities is not invited, then the artwork is not public."

Dr G Rose

Public Art Research Project

The Open University



priorities.

It would also be interesting to find out at what point either the WMBC and/or the Wallasey Central Park Group would have put the call out for a public art commission (if at all), had the artist not approached them first, and whether this would have been a joint venture between the council and the Park Group or not?

#### Integration with wider renovation project

Many members of the local community who were interviewed were particularly upbeat about seeing lots of things happening at once and clearly found this very uplifting.

It has been evident from a wide range of comments made that the sculpture came to represent a kind of “icing on the cake” of the park’s renovation for many of the people involved. This created a lot of goodwill for the project and contributed to a wider level of engagement within the community through an increased level of awareness about what was going on in the park generally.

Due to the lucky timing already described above this turned out to be a benefit, however recommendations for future projects are that the integration needs careful management. As the Council’s Landscape Architect pointed out, it is difficult to maintain interest amongst participants, especially young people, when lead times are too long, or if funding is slow in coming through. Again, a retrospective analysis of the overall project plan would be useful as well as some understanding of how to try and “embed” public art programmes into future renewal, regeneration or restoration programmes being run by public or private authorities.

#### Involvement/local engagement

There can be no doubt that the artist succeeded in engaging a wide range of groups locally and in particular the local young people.

This level of engagement has helped to meet some of the artistic aims for ‘Just Wait For Me’ as outlined in the original proposal to Arts Council England;

“to empower, raise expectations, and instil pride and a sense of belonging. It seeks to add value to the young people’s experience of their environment enabling them to actively influence what is going on in ‘their’ park and to contribute to society by shaping the environment.”

The engagement programme also fits well with the Wirral Metropolitan Borough Council’s remit for public service that includes aims for social cohesion, community development, crime and safety and improving the (urban) environment and access to facilities.

Instrumental in the process of fulfilling the project’s social and environmental aims were the

relationships developed with the WMBC and the Wallasey Central Park Group and the objective of “developing constructive relationships” between various bodies and the artist has therefore been fulfilled. The assistance of the Park Group was vital in that it represented a steering group for a large number of individual user groups within the park. It does appear to be the case that the level of local knowledge and contacts that the artist was able to draw upon has been hugely helpful in terms of local engagement and involvement. Another factor in the project’s success was the expert knowledge of the Council’s Landscape Architect who had worked with artists previously and was able to contribute positively with several ideas of her own and bring her experience to bear.

Recommendations for the future would be to continue to build on these strong relationships and perhaps to encourage other artists to take more responsibility for becoming involved at a local level with their council and with groups with a social and/or environmental interest. This could increase awareness of, and possibilities for, similar opportunities where this kind of “bottom up” approach to initiating projects can be taken.

#### Benefits of participation for young people and schools

These benefits simply cannot be overstated. The objective of “working with young people and involving them in the project” has clearly been met. Both teachers and pupils alike were glowing with praise for the way that the artist had involved them and the contribution that the experience had made to their education programmes and artistic development.

The recommendations for future projects (which were keenly anticipated) were that there should be slightly longer lead-in times to allow for better preparation and planning, and that it would be even better if the experience could be made to contribute in some way to the ‘A’-level GCSE portfolio and/or final examination mark.

Thus for WMBC also, the benefits accrued in terms of providing young people with excellent opportunities in the local area for personal development and skills acquisition were very much in evidence.

In conclusion, it appears that the artist’s evident ability to connect with people and to develop constructive relationships, together with her professional approach to working with young people and being able to involve them in the creative process contributed significantly to the success for the project.

To examine the remaining objectives, or ‘Desired Outcomes’ in more detail, a further research study is recommended for the summer months which will give the artwork time to “bed in” and gain exposure to a wider audience.

APPENDICES:

Appendix One: Transcript of interview with school teacher

Appendix Two: Quantitative Questionnaire draft

## Appendix One: Selected Transcription of Qualitative Interview

### Depth Interview with: Teacher

NH: It shouldn't take long; really, what it was, was just to get a bit of feedback on the project from your perspective, how you got involved in the first place ...

ST: I got an e-mail, I think, sent from Brigitte, she was asking all schools, erm, on the Wirral, no, she said someone had recommended us, that we'd be very interested 'cause of our art things, I think maybe through the Biennial, and she got in contact with us, I think that's what it was. She said "Oh I've heard that I think your school'd be interested."

NH: And the approach, was it something that you jumped straight into, or was it difficult to fit it in?

ST: Erm .... No, it was something that we could jump straight into, I mean, it's like anything else isn't it, it's as easy or difficult as you make it?! (laughs) Do you know what I mean? So I think it was fine really, she just said "Would you like to come down?" We had, I think it was about a month's notice wasn't it? So it was fine because we could organise it. If it had been a week's notice we couldn't have done it, even two weeks is a bit short but a month kind of gives us enough time ...

NH: ... to fit it into your schedule?

ST: Yeah. Anything less than a month and really we would have struggled, only 'cause of, really, constraints that the school puts on, you know, not because of changing for the students, it's just filling in paperwork for the school really.

NH: And how many students were involved?

ST: Erm ... well we took about a minibus ... erm ... so that's about sixteen to eighteen students of all groups from I think Year 9, 10, 11 and 12, I think it was, wasn't it?

NH: So across the spectrum?

ST: Yes, we did across; we did a mixture, and then erm, er .. Yes we got the minibus down to the studio and they really enjoyed that; they loved going into the studio.

NH: Is this in Balls Road?

ST: Yes, the new one.

NH: Oh, the new one.

ST: Yes, the new one. But it's always funny isn't it when students go into a different environment? I mean they're literally so quiet. They did not speak. I mean Brigitte's used to working with students. It's not that they're not interested, it's just that naturally teenagers are so quiet when they're out of their normal environment aren't they, you know? But they did actually really enjoy it.

NH: And how were the workshops introduced?

ST: Erm, so then, err ... Brigitte talked about what the project was, showed us some of her work and explained, explained first of all really how she'd come about in her work and I asked her to talk to us a little bit about being an artist and what it was like for her and where she got her work just to give them an insight career-wise and then she did that, and that was lovely, and then she showed them some of her work, and she talked through, erm, the project proposal, and showed them some of the little cats that she'd done, and then explained that she was going to come in and work with them and do photographs, and then work with them on a workshop.

NH: Right. So on the session that you did, it was a studio visit rather than a workshop?

ST: No, we ended up doing both. We went to the studio, and then a week later ...

NH: Oh, so it was a week later you went back?

ST: Yeah. Erm, no, a week later she came into school.

NH; Oh right, so the workshop happened here?

ST: The workshop happened here, yeah, with the students in school. So it was good for them because it gave them insight into what she was about ...

NH: It's a nice way to do it, isn't it?

ST: ... and then, you know, erm, taking that through and forward into their own work which they really enjoyed, you know.

NH: And were they introduced to themes, or what was the kind of structure?

ST: Erm, ... The theme was, erm, basically we looked at ... erm, Brigitte talked in the workshop about figures and poses and like almost like things that we just do naturally we see in kind of classical sculpture as well and she talked to them a little bit about that and then she just said to them I think just work in sort of pairs, work in group work and trying to show friendship, and different poses about friendship and dynamics, if I remember rightly, I think that's what it was about.

NH: Did the workshop kind of pull out ideas in looking at the finished object?

ST: Oh yes. The workshop was brilliant because what they did was, they worked with this material, and I think Brigitte will know, it's like beeswax that the students really enjoyed working with. And what they liked about it was that working with it, from start to finish, getting the idea; the stuff was malleable enough to kind of have a finished product by the



end of the session. I think they kind of liked that, you know.

NH: That's brilliant. So these works were malleable enough. And did the sculptures stay with Brigitte?

ST: No, the sculptures went back with Brigitte, yeah. It would've been nice, if maybe, I know Brigitte needed them and that was great, but maybe if they, I don't know, kept a couple. Or, it would've been nice in an ideal world if they could've made two but that's time constraints. Like one could've gone with Brigitte and one could've stayed ...

NH: So they had one each.

ST: ... with them, yeah, just so, almost like for their portfolio, you know, to show what they'd learned.

NH: Maybe they could get some images of them.

ST: Yes she did, she sent us some. What we did, is, she sent us some images and she borrowed, erm, a, you know, thingy or mine, you know, what d'you call it?

NH: A data stick?

ST: Yeah but when it came back it had broken in the post so that was a bit of a shame.

NH: So you really need more ...

ST: So we'd love to get more images but I didn't have time to get in touch with her and tell her about that.

NH: I'm seeing her tonight so I'll try and remember to ask her.

ST: Yeah, that'd be great. Or even if she just e-mailed me a few. That'd be great. Probably easier to do that than, you know, taking time out to post it.

NH: Yes, or possibly just pop them in at Reception or something?

ST: Yeah. That'd be great.

NH: So in terms of the workshop, was there anything, you know, that could've been done better?

ST: Erm ...

NH: Or that could've been improved about it?

ST: I think the students really enjoyed it. I think what, I think sixth form students, for me, it was really good for them because the feedback I got back from the sixth formers was that they found her really interesting to talk to; as I say she really inspired one of the students who's in my form, erm, was really pleased with her work and it gave her loads of confidence and Brigitte said to her "You've obviously got an ability at this" and she talked to her about doing architectural sculpture and [she'd] never thought about that before and now, as I say,

she's applying to do architecture. And from that I got her placed onto an architecture course in John Moore's University and now that's what she wants to do. She gave her a career and input that she would never really have considered before at all.

NH: And that's a really good thing, isn't it?

ST: That is excellent. And I think for them, having a practising artist who's obviously working internationally, knows what she's talking about, is at university herself lecturing, I think it gives them real confidence that someone like that is saying to them, you know, "Have you considered this?" or "You're good at that ... " sort of thing. I know [student's name] would say that if she was here now but I can't get hold of her.

NH: No but that's really good feedback so that's really made a difference.

ST: Yeah, yeah

NH: So for sixth formers it was a big win really, and to be able to deal with someone who's seriously involved in her practice?

ST: Yes, yes. Absolutely and I think that's great for the kids. I think if they were going to do anything different it would be [interruptions from pupils bringing work over] it would have been nice to, I don't know, it's an ideal world, isn't it? Maybe they could've had, like, two on the go and kept one, or had something to show for themselves possibly. Maybe, in hindsight, if I would've done it again I would've got their sketchbooks taken down to the studio, got them to sketch some of Brigitte's stuff in there, maybe had a go with the material and done some research on it so the whole process could be more evident for when they get assessed. Selfishly, for them!

NH: No but that's an interesting way of thinking of it so maybe next time if there's another approach, or it's that whole thing about topping and tailing it so it's more integrated with the programmes here.

ST: Yes, yes. That would be great. Just so that they can get maximum out of it you know, for their portfolios really.

NH: So it's kind of before and after research and development?

ST: Yeah, yeah. Or even if myself and Brigitte, or whoever was running the programme, if we kind of went, "Ok, if we kind of do it two or *three* months in advance" we can really, you know, get a decent bit of work out of it.

NH: Fantastic. And from the point of view of the younger students, what were their thoughts about it, do you think? What were their responses?

ST: I think they enjoyed it but because, you know, the youngest ones there in the studio were kind of like, they were kind of like .... I think if they'd 've been Year 7, I think it would've been different. Year 6 and Year 7, they would still be at the age to be like "Oh, wow!" but that sort of – I think it was Year 9's that we took that was the youngest actually, Years 9 and 10, they were still a bit, or was it Year 10? Ten and eleven, twelve and thirteen

– they were still a bit, they were a bit kind of like “What’s it all about?” kind of, like, I think. Just out of their environment.

NH: It’s an alien environment, they haven’t kind of got the context as much as the sixth formers.

ST: They haven’t.

NH: And they’re not at the same level of thinking about how art is working.

ST: No, no. And they’re not as free-thinking as a Year 7 or a Year 6 would be.

NH: This is what I’ve been finding with primary age groups.

ST: Yes. They’re much more free-thinking.

NH: When they first come into secondary school they’ve still got that kind of wonder of things..

ST: They have, yes.

NH: And they’re not making judgements.

ST: And then something awful happens! And it goes until they get to, really, about Year 10 or a Year 11 in some cases. It’s horrible really. I don’t know what we do to them! I guess a lot of it’s hormones and all that lot, and their friends are more important, but it does seem to be that they lose the willingness to be uninhibited for a couple of years, you know.

NH: Yeah, I think hormones play a big part.

ST: They do.

NH: And also, there’s an element of boxing things up rather than being broad in their thinking.

ST: Yep, yes, there is.

NH: And even though that’s happening in primary school, they don’t ... they’re kind of quite indiscriminate about the things that they’ll do because they’re just looking for enjoyment. I think there’s this idea of it not being as enjoyable.

ST: Yeah, yeah. Yes, there is.

NH: Maybe that’s what happens.

ST: Yes, I do think a lot of it’s the way we deliver things in secondary as well ...

[General discussion ensues about creative thinking and different approaches to teaching art to children and young people].

END OF INTERVIEW

## Appendix Two: Quantitative Questionnaire Draft/Sample

[Screening question]

1. Hello, I'm conducting a survey to collect information about people's use of the park and their opinion on the park's artwork. The interview lasts about ten minutes. Would you like to take part?

Yes (go to Q.2) .....1

No (terminate) .....2

2. How long have you been coming to the park?

Never been before/first visit ..... 3

Don't know/can't remember .....4

3. I'm going to read out some things that people have said that they do in the park. Can you tell me which of these things you use the park for?

Tick start/ (vary)	Read out:	Ring as many as apply
	go for a walk	1
	play on swings/take kids to play	2
	play sport	3
	meet friends	4
	sit, rest and relaxation	5
	visit cafe	6
	look at sculptures	7
	attend performances/events	8
	cut through on my way somewhere	9
	Other (specify)	0

4. During 2011/12, the park underwent a general upgrade that included an art project, did you participate personally in the art project in any way?

Yes ..... (go to Q5) ... 1

No..... (go to Q6)..... 2

5. What involvement did you have?

---

6. Do you agree that sculpture is a good way to use art to shape and beautify the local environment?

Yes ..... 1

No.....2

7. Do you agree that the sculptures in the park provide a unique and high quality artwork?

Yes ..... 1

No ..... 2

8. Do you agree that the sculptures improve the image of the park?

Yes ..... 1

No.....2

9. Do you agree that the sculptures help to improve the image of the people who use the park?

Yes ..... 1

No..... 2

10. Do you think that the sculptures create a positive, celebratory image of young people?

Yes ..... 1

No..... 2

11. Do you think that the sculptures are a focal point within the park?

Yes ..... 1

No ..... 2

Thank you. Finally, if you have any additional comments of your own that you would like to make about the sculptures, please feel free to tell me these now;

---

---

---

Thank you. Now I'd like to ask you a few basic questions about yourself that will help us to understand the results of the questionnaire better. This information will be kept in strict



confidence in accordance with the terms of the data protection act etc etc.

Standard Classification questions .... sex, age, working status, postcode etc.

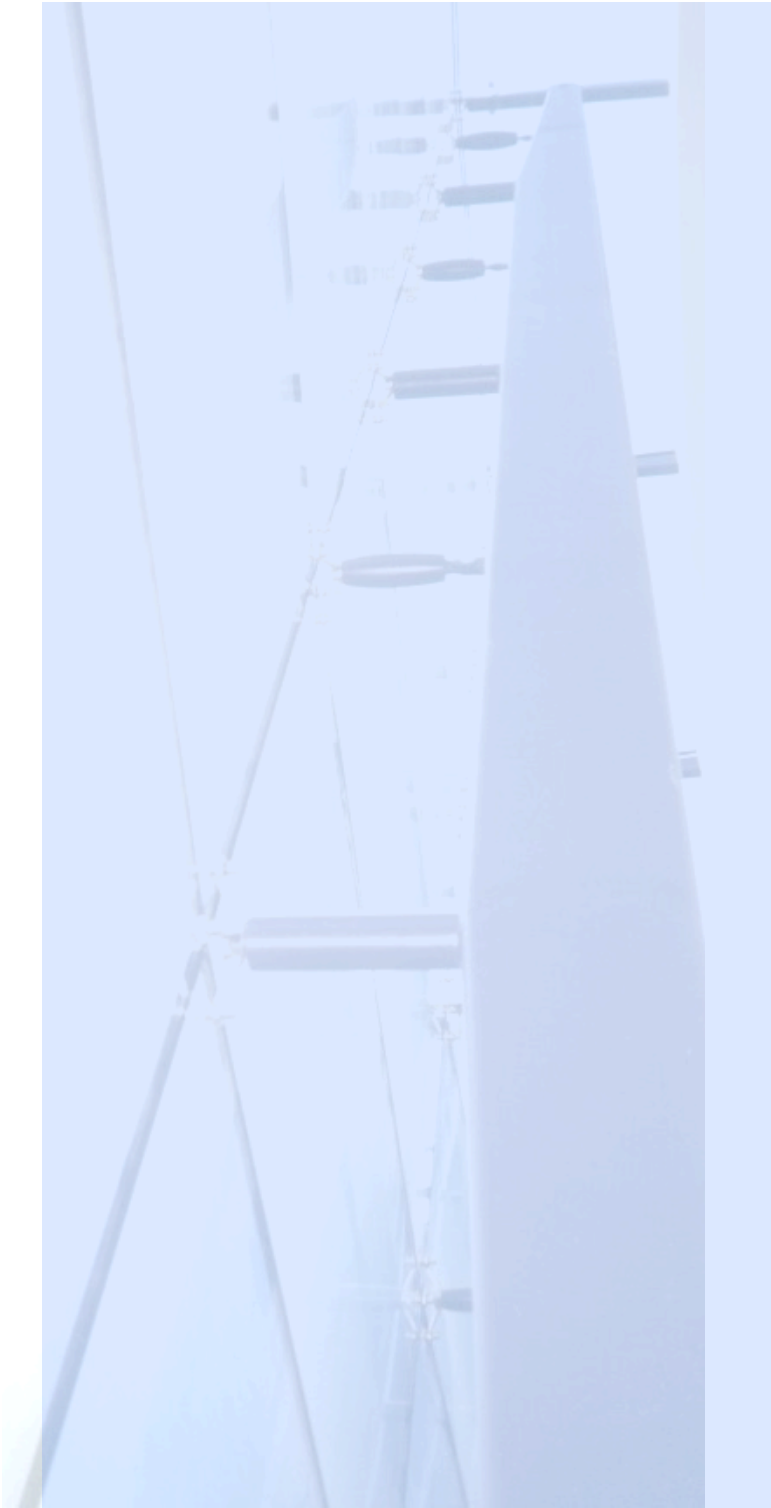

**(dp)<sup>2</sup>**

**Brigitte Jurack**

**Piggy Back Sculpture**

**Structural Engineering  
Calculations**

DP Squared Ltd

Second Floor  
4 Albert Street  
Hebden Bridge  
HX7 8AH

Mail@dpsquared.net :E

01422 846693 :T

Structural Engineering Calculations

For

Piggy Back Sculpture

For

Castle Fine Arts

August 2012.

Ref : dp2 / 1246

Report Prepared by D.Paine

B.Eng C.Eng MICE



Rev	Date	By	Comment

## **Building Regulations Submission**

### **Contents**

- 1. Introduction**
- 2. Design Calculations**
- 3. Design Sketch**

## 1. Introduction

The following calculations are provided for the overall stability and internal frame to the Piggy Back Sculpture by Brigette Jurack.

A mass concrete base consisting of a 1200mm diameter manhole ring provides the stability of the piece. Within the sculpture a steel frame resists the overturning loads due to wind.

An accidental load has also been incorporated to allow for the possibility of someone climbing on to the sculpture.



## 2. Design Calculations

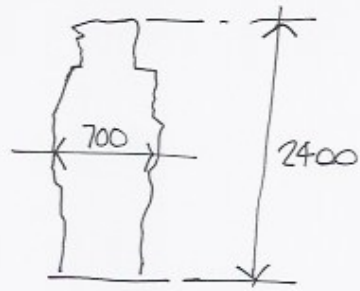

WIND  
ELEVATION

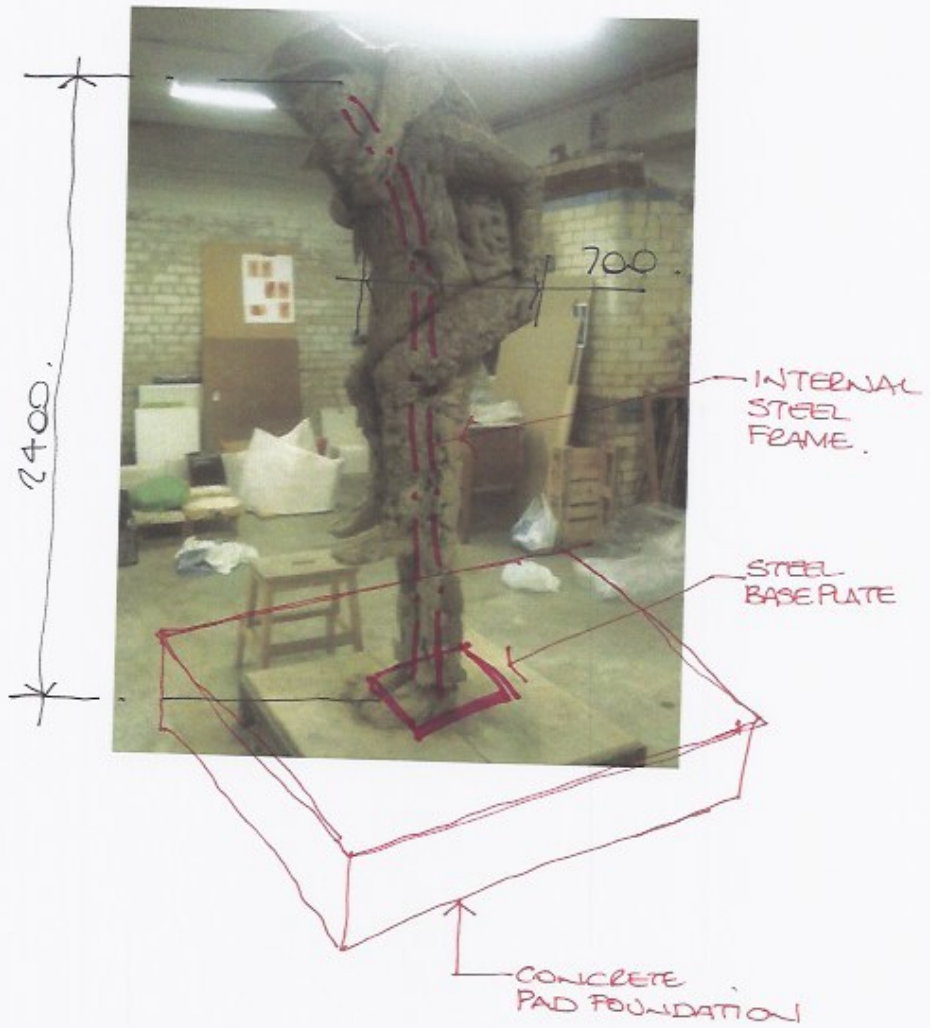

9081 BRIGITTE JURACK SCULPTURE

Project: BRIGETTE JURACK

Sheet: 001

defined by design

(dp)<sup>2</sup>

Calculation Title:

O/A STABILITY

Project No.: 1245

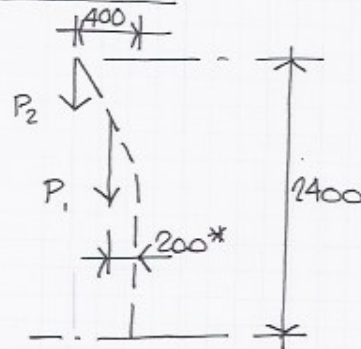
IDEALISED FRAME

\* CONSERVATIVE ASSUMPTION

$$\begin{aligned} w \Rightarrow q &= 1.0 \text{ kN/m}^2 \\ C_{pe} &= 2.0 \\ w &= 2.0 \text{ kN/m}^2 \end{aligned}$$

$$P_1 = S/W \text{ of sculpture} = 100 \text{ kg}$$

$$P_2 = \text{Accidental load} = 150 \text{ kg}$$

Total overturning

$$\text{Wind} = 2.0 (0.75 \times 2.4) \times \frac{2.4}{2} = 4.32 \text{ kNm}$$

$$S/W = 1 \times 0.2 = 0.2 \text{ kNm}$$

$$\text{Accidental} = 1.5 \times 0.4 = 0.6 \text{ kNm}$$

$$\rightarrow 5.12 \text{ kNm}$$

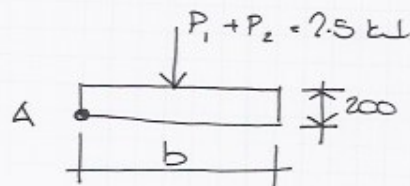
BASE RESISTANCE

$$M_2 = \frac{2.5b}{2} + (0.2 \times 24 \times b^2) \frac{b}{2}$$

$$> 1.5 \times 5.12 = 7.7 \text{ kNm}$$

$$\text{for } b = 1.5 \quad M_2 = 9.97$$

Restoring about A (with Fos = 1.5)

$$S/W \text{ base} = 10.8 \text{ kNm}$$

∴ Adopt 1500 sq.

$$M_{res} = 9.97$$

$$\text{Factor of Safety} = \frac{9.97}{5.12} = 1.95 > 1.5$$

Project: BRIGETTE JURACK	Sheet: 002	defined by design (dp) <sup>2</sup>
Calculation Title: o/a STABILITY	Project No.: 1245	
	AUG 2012	

It is intended that the structure will be set in a section of concrete ring →

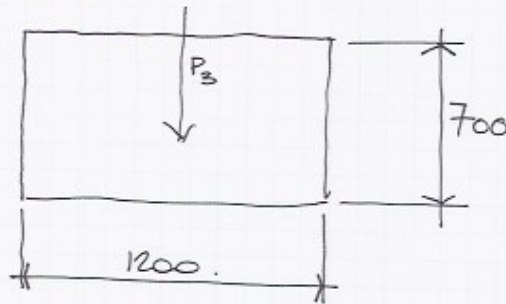

take a nominal density of  $18 \text{ kN/m}^3$

$$S/W = \frac{1.2^2 \times \pi \times 0.7}{4} \times 18 = 14.3 \text{ kN}$$

$$\text{Resistance to overturning} = (14.3 + 2.5) \times 0.6 = 10.1 \text{ kNm}$$

↑  
( $P_1 + P_2$ )

$$\text{Factor of safety} = \frac{10.1}{5.12} = 1.96 > 1.5 \therefore \text{ok}$$

Project: BRIGETTE JACK

Sheet: 003

defined by design

(dp)<sup>2</sup>Calculation Title:  
INTERNAL FRAME.

Project No.: 1745

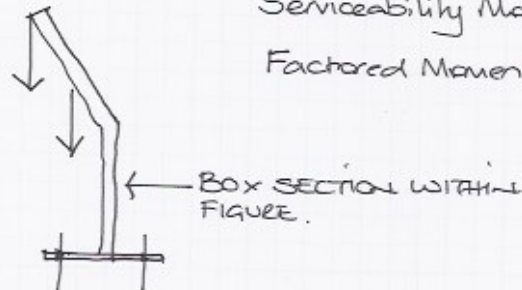

Serviceability Moment = 5.12 kWh.

$$\begin{aligned} \text{Factored Moment} &= (1.4 \times 4.32) + (1.4 \times 0.2) \\ &\quad + (1.6 \times 0.6) \\ &= 8.7 \text{ kWh.} \end{aligned}$$

deflection under wind load.

A hand-drawn diagram of a vertical member fixed at its base. A uniformly distributed load is applied horizontally along the length of the member. The member is labeled 'wind elevation = 0.75m'.

$$w = 2.0 \text{ kN/m}^2$$

$$s = \frac{wL^4}{8EI}$$

$$l = 2.4 \text{ m}$$

$$w = 1.5 \text{ kN/m}^2$$

$$I \gg \frac{1.5 \times 2.4^4}{8 \times 205 \times 10^6} \times 8.$$

but, also limit  $s$  as part of a natural frequency check. set  $f > 8 \text{ Hz}$ 

$$f = \frac{19.7}{\sqrt{y}} \rightarrow y \leq 6.1 \text{ mm}$$

$$\therefore I \gg 4.9 \times 10^6 \text{ mm}^4 \quad (490 \text{ cm}^4)$$

Strength check.

$$p_y = 200 \text{ N/m}^2$$

$$Z_{\text{req'd}} = \frac{8.7}{0.2} = 43.5 \text{ cm}^3$$

$$Z_{\text{net}} 80 \times 80 \times 6.3 \rightarrow Z_{\text{total}} = 81 \text{ cm}^3$$

$$\& I_{\text{total}} = 324 \text{ cm}^4 \quad (8.9 \text{ mm})$$

$$\rightarrow \text{freq} = 6.4 \text{ Hz} \therefore \text{say okay!}$$



Project: BEIGE JACK .

Sheet: 004

defined by design

(dp)<sup>2</sup>

Calculation Title:  
BASE PLATE .

Project No.: 1245

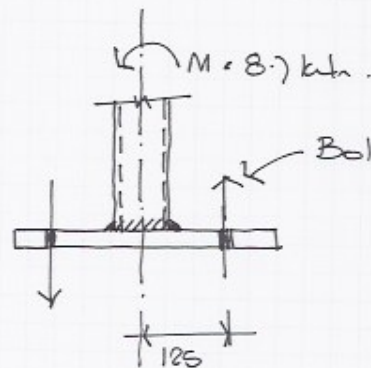

$$\text{Bolt force} = \frac{8.7}{2 \times 0.125} = 34.8 \text{ kN}$$

$$\text{Unfactored} = 4.2 \text{ kN}$$

Adopt M20 HILTI HY150

$$\text{Bending on plate} = 2 \times 34.8 (0.125 - 0.04) = 5.9 \text{ kNm}$$

$$\text{Assume plate 400 wide, thickness} > \sqrt{\frac{5.9 \times 10^6 \times 6}{265 \times 400}}$$

$$t \geq 18.2 \text{ mm}$$

∴ 20 thick base plate .

### **3. Design Sketch**

Project: BELKITE JURACK

Sheet:  
SK-1245-001

defined by design (dp)<sup>2</sup>

Calculation Title:  
PRAY BACK SCULPTURE.

Project No.: 1245  
DEP | AUG 2012

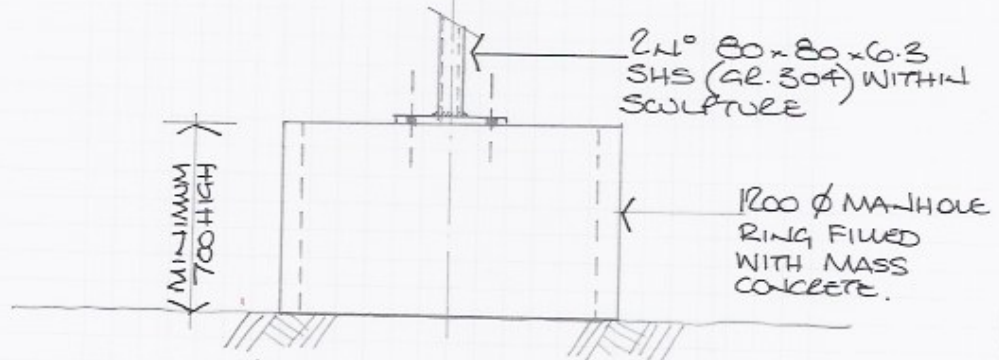

SIDE ELEVATION OF FOUNDATION



VIEW OF SCULPTURE.

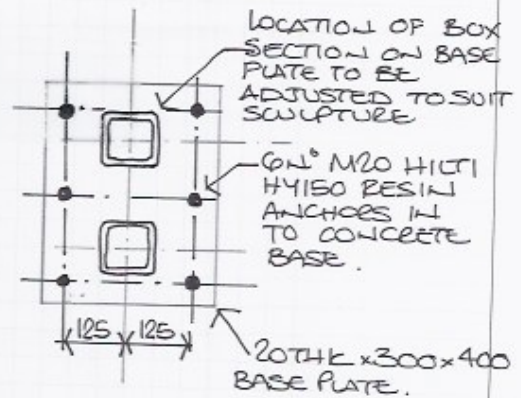

PLAN ON BASEPLATE

2x1° 80x80x6.3  
SHS BENT TO FOLLOW  
SHAPE OF SCULPTURE.

## **Dates of workshops**

### **The Hub**

06.04.2011  
27.04.2011  
28.06.2011  
24.08.2011  
31.08.2011  
07.09.2011  
06.10.2011  
13.10.2011  
11.01.2012  
18.01.2012  
15.02.2012

### **Weatherhead High School, Keystage 4**

11.06.2012  
18.06.2012  
25.06.2012

### **St Mary's Catholic College, Keystage 4 and 5**

19.06.2012  
27.06.2012

### **The Oldershaw Academy, Keystage 5**

29.11.2012

### **Grundy Art Gallery, Blackpool**

09.02.2012  
13.02.2012  
23.02.2012  
24.02.2012  
27.02.2012

Please fill the following in:

Initials only:

Male/ Female:

Age: 14-16; 16-18, 18-20, 20-25, 26-30, 30-35, 36-40, 40+



Do you know what is going on in this statuette? Yes/ no

Please describe, what you see:

Please develop a short interpretation of what you are looking at:  
(you may continue on the other side)

1

---

<sup>1</sup> Oct.2011/BJ/1



Please fill in the following:

Initials only:

Male/ Female:

Age: 14-16; 16-18, 18-20, 20-25, 26-30, 30-35, 36-40, 40+



Do you know what is going on in this statue? Yes/ no

Please describe, what you see:

Please develop a short interpretation of what you are looking at:  
(you may continue on the other side)

2

---

<sup>2</sup> Oct.2011/BJ/2

Please fill the following in:

Initials only:

Male/ Female:

Age: 14-16; 16-18, 18-20, 20-25, 26-30, 30-35, 36-40, 40+



Do you know what is going on in this photo? Yes/ no

Please describe, what you see:

Please develop a short interpretation of what you are looking at:  
(you may continue on the other side) <sup>3</sup>

---

<sup>3</sup> Oct.2011/BJ/2

## **MEETING HELD ON WEDNESDAY 9 May 2012, Liscard Cricket Pavilion**

### **PRESENT:**

COLIN SIMPSON (CS)	Curator, Williamson Art Gallery, Wirral Borough Council
JACKIE SMALLWOOD (JS)	Wirral Borough Council
CHRIS DAVIES (CD)	Friends of Central Park
BRIGITTE JURACK (BJ)	Artist

Apologies from: Laurie Peake (Biennial Liverpool), Naomi Horlock (freelance evaluator), Jo McGuire (WBC)

Ms Jurack showed a brief slide presentation of her Proposal to Mr Simpson, as the other members of the meeting had previously viewed the proposals during an earlier meeting of the Friends of Central Park.

Various points were discussed and these are summarised under the following headings:

### **FUNDING APPLICATION PROCESS and COSTS**

The cost of the project as stated in the Arts Council application form will be £31,500 + VAT. The majority of this sum will be paid to the Casting Foundry (£25,000 +VAT). Ms Jurack provided the meeting with a financial breakdown of the costs. She outlined the sequence of events leading up to her application to the Arts Council, and their subsequent formal agreement to provide funding of £18,500. Manchester University has agreed to provide £3,500, leaving a shortfall of around £10,000.

During earlier meetings leading up to the Arts Council funding application, which was discussed, read and supported by JS from WBC. As it is in the nature of matched funding applications, the application states an expected funding of £10,000, of which some is "in kind support". BJ outlined the anticipated contribution from the Council. JS advised that any funding provided by the WBC would need to be below the £10,000 threshold due to the Council's tendering process.

A condition of the Arts Council grant is that the Council also provide a contribution.

The costs shown in the breakdown do not include VAT and therefore this would be an additional cost which would require to be funded. BJ asked if funding could be provided in such a way that the VAT burden could be minimised.

BJ once again expressed concern at the shortfall in funding and pointed out that there were certain elements of the works that could not be compromised, in particular the safety aspect surrounding the actual installation of the sculpture.

BJ confirmed that some savings could be made by casting in aluminium (£2000). Whilst aluminium is not as robust a material as bronze, the final finish of the sculpture would be paint and therefore aluminium would not compromise the project aesthetically.

JS confirmed that the Council would only make a payment directly to BJ and not to Castle Foundry who will execute the works. CD and CS suggested that the special service by Castle Foundry to lift and install the work should at least be considered to be paid for directly by WMBC. This is estimated by Castle Foundry at £1,440 +VAT

**Action: further clarification needed towards the financial contribution by WBC. Clear identification of the need for the specialist service of Castle foundry in regards to installation.**

JS asked what WBC's level of responsibility would be and what the insurance situation would be. CS advised that the sculpture once installed should be treated like the sculptures on Hoylake Roundabout, thus falling into the Council's insurance policy. BJ advised that as stated in the original Arts Council application is designed to last for a minimum of 25 years. Wirral Metropolitan Borough Council will have full copyright use of images and a contract in regards to ownership, copyright and maintenance will have to be drawn up between WMBC and the artist.

**Action: further clarification needed in regards to insurance and maintenance for next meeting. Jo McGuire and CS to provide more details.**

**Further clarification needed in regards to the pro-forma of the contract. Examples should be available at WMBC. Ask JoMcGuire for her expert input.**

CS suggested the possibility of having an exhibition of the sculpture maquettes, drawings etc. in the Williamson Art Gallery and the potential of exhibition fees or purchase of a maquette.

**Action: BJ and CS discuss the potential of an exhibition separately at the Williamson or BJ's studio.**

#### **FINAL POSITION OF SCULPTURES**

BJ confirmed that the final position of the installation would depend on the Council's landscaping plans for the area of the former Liscard Hall.

Height and type of foundations will depend on the Council's landscaping proposals for the site. JS advised that it will not be possible to dig too deeply; therefore some type of plinth may be necessary. It was agreed that raising the sculpture would be advisable due to the proximity of the car park area which may obstruct the sculpture from view. BJ suggested that a brick plinth or cast concrete might be suitable. It was also agreed that it may be necessary to site the sculpture nearer to the garden areas where the ground is more stable.

JS confirmed that the landscaping proposals have been scheduled by WBC for the current financial year and planned to be completed late summer.

BJ confirmed that the footprint of the sculpture would be one metre square. JS asked that BJ provide loadings to allow her to calculate the required footings. JS asked if a crane would be necessary to erect the sculpture in place. BJ confirmed that the overall sculpture will not be too heavy. The separate installation of the seated girl sculpture was not discussed at this stage, because

this figure will be made out of cold bronze (laminated resin). It is planned that the seated girl is perched on a higher plinth. Further design specifications required.

**Actions:**

**BJ to provide weight specs and installation specs by contacting the foundry. BJ to enquire if a plinth is provided by foundry asap.**

**JS upon receiving these specs the decision can be made in regards to the exact location of the sculpture (problem of ground disturbance)**

Further details in regards to the colour of plinth should be considered as part of the overall design of the upgrading plans (stage, arena) and CD suggested to consider seating around the sculpture. BJ stresses that she is happy for some of the young people's designs produced during the workshops to be integrated into the upgrading design. However, any resulting production of signs/ decorative elements would have to costed separately.

**PROPOSED INSTALLATION DATE**

BJ provided a timeline of the various elements of the project. The earliest anticipated installation date is 12<sup>th</sup> of September 2012 which would coincide with the Biennial opening (14.09) and allow the project to share publicity for this event. BJ intends to use one of the interns assisting with the project to design a leaflet and then to pay a local company to carry out a blanket leaflet drop. There will also be an article in the Wirral Globe.

**SCHOOLS INVOLVEMENT**

BJ confirmed having contacted several local secondary schools. Only two returned positive feedback and are keen to be involved in the project (Weatherhead and St. Mary's). BJ still plans to do workshops with Oldershaw and Mosslands but has not heard back yet. CS asked if BJ had contacted any of the primary schools but BJ advised that the workshops were specifically aimed at secondary school ages. CS asked that the primary schools be kept informed.

**EVALUATION**

BJ confirmed that the project will be evaluated on a freelance basis by Naomi Horlock whose fee will be paid from the Arts Council grant.

**CONCLUSION**

The meeting concluded by everyone agreeing how exciting the project is and that BJ is an internationally-known artist living locally and doing something for the community.

**NEXT MEETING**

**The next meeting will be held on 19 June 10 am at BJ's studio, 57-59 Balls Road East, Birkenhead to allow the attendees to view the progress of the sculpture.**



Minutes **Just wait for me**, sculpture for Central Park , Liscard

Meeting: 19.06.2012, 10 – 11 am, 57-59 Balls Road East

Present:

Brigitte Jurack

Chris Davies (Friends of Park)

Jackie Smallwood (WBC)

Apology:

Collin Simpson WBC

Steve Chan ( Youth Service)

## **1. Update on progress**

### **Workshops:**

school workshops have commenced:

3 x 2hours after school with Weatherhead ( 12 students)

studio visit from St Marys ( 25 students on 19.06 2.15 -3.35pm)

Oldershaw: twilight sessions in September, they have too much on before summer( enrichment week)

No response from Mosslands

3 more sessions planned with Youth Hub, but they will take place during summer vacation period.

### **Sculpture:**

Chris and Jacky both took photos of work in progress. Initially surprised by the size both understood, that seen from a distance the work will be feel life size.

Also, we discussed plinth and plinth height, suggested to be about 50 cm high.

Plinth material: concrete, but cast in smooth shuttering , CD suggested circle , possibly contacting Laird Apprentice school for circular “offcut” ;

Concrete might be coloured depending on overall colour scheme of the area. ( concrete can be tinted in reddish, white, sand stone yellow ) or coloured in any Keim Colour.

BJ talked about the designs created by Weatherhead girls, and the possibility of integrating these in the overall scheme ( ie. on the seats, the signage, the publicity material) , one image is attached to these minutes for purpose of illustration.

## **2. Update on Finance/ Budget:**

BJ reported that :  
Castle Fine Arts Foundry received £1800,-- (including VAT) for the fabrication of armature.

Materials for all Workshops paid for by MMU

CD reported that the Friends of the Everyone's café wish to contribute towards the project.

JS still no further details as to how much the Council is going to contribute.

BJ reported that she is required to write an interim report to the Arts Council in July in order to release further Arts Council funding. However, in the absence of any clear indication as to the commitment of the WBC she will NOT be in a position to complete interim report to the Arts Councils satisfaction, thus not only delaying the next payment, but also potentially jeopardizing the delivery of the project. Current fund sufficient to pay for mold only.

### **Action:**

**CD report on next meeting on outcome of Friends of Everyone's Café meeting.**

**JS report on next meeting the financial commitment of WBC**

## **3. Structural engineer for plinth:**

BJ need to have structural engineer for plinth.

And installation details.

Installation details (access of lorry) were emailed to JS who foresees no problems .

### **Action:**

**JS to approach council's structural engineer**

**BJ approach Foundry for further details of how the work will be fitted into/onto plinth and recommendation for structural engineer**

Estimated cost for drawing: £150,--

## **4. Upgrading of area:**

Upgrading of area has not gone to tender yet. BJ reporting on the design ideas the girls from Weatherhead have come up with.

JS reported, that work will begin late summer , and since tender is not gone out yet, suggested that BJ provides the results of her workshops for possible inclusion in overall upgrade design.

( a suggestion of these are included at the end of this report, however, the final design workshop at Weatherhead and St Mary's is on Wedn. 27.06. whereupon BJ will be able to provide visuals too).

Location of sculptures: within overall design, the piggy back sculpture should face stage or playground area.

**Action:**

**BJ to forward design ideas of school students to JS a.s.p.  
JS report back on when work is to commence.**

**5. Contract/ ownership/ maintenance**

Not discussed but this is a reminder of previous meeting action point:

**Action:**

**BJ to provide sample contract (IXIA) for WBC for next meeting**

**Next meeting:**

**Thursday, 12<sup>th</sup> of July, 10 am 57-59 Balls Road East.**

**Agenda:**

- seeing sculpture before mold is taken
- publicity material ( no meeting in August), draft ideas
- financial up dates

**Appendix:**

**Some suggestions from workshops/interaction with pupils:**

**For seating:**

**scattered cast concrete cardboard boxes (varying sizes). The idea would be to cast them in ocher/sand stone coloured concrete ( see suitcases on Hopestreet Liverpool). On the side of each "box" could be a small image of the designs the students have created (see image attached)**

**For stage:**

**Or wall behind stage:**

**Integration of the "flat pop " images created by the students**

Minutes Just wait for me , sculptures for Central Park, Liscard

Meeting: 12.07.2012 10- 11

Present:

Chris Davies (CD)

Jackie Smallwood (JS)

Collin Simpson (CS)

Brigitte Jurack (BJ)

Michelle Langan

### **1. Update on Progress**

BJ showed some photos of the student's work of school workshops (Weatherhead and St. Mary's) , this included some drawings for a stage/and treatment of the brickwall.

BJ suggesting to pick up the workshop sessions with the HUB during summer vacation.

And Piggyback sculpture at point where the mould would be taken.

Interim Progress report send off to the Arts Council on 26<sup>th</sup> of June 2012

JS showed visualizations of the environmental upgrading of the Old Hall site, including a mock up of the sculpture , some hard shoulder paths, beautiful trees and pebble shaped seating. The image also included a stage and cladding of brick wall and further greening of the wall.

Height and dimensions of plinth discussed. Proposal: to use a pre-cast drainage pipe (concrete). This was since discussed with foundry who will do the installation of the work.

Also discussed further seating at the base of sculpture, though this might be too crowding. The pebble seats with possible two more traditional benches would be more suitable in the overall scheme.

**Action: BJ source concrete "ring" and make decision on height of ring. BJ and JS to meet in the park with structural engineer to discuss location and fixings. BJ to source and appoint structural engineer.**

### **2. Funding**

**Great news. The funding is now in place as confirmed:**

£18.500, -- Arts Council England

£ 9.500,-- WBC

£ 1.000,-- Everyone's Café, Central Park

£ 6.332,-- MIRIAD ( tight mainly to cover staff costs)

(possibly Friends of the Park).

**Many thanks for the support thus far. BJ expressed her gratitude towards the Everyone's Cafes commitment especially.**

### 3. Time scale

Sculpture of piggyback group set to be completed in time ( September). BJ will commence 3<sup>rd</sup> figure , the seated girl upon return from Holiday.

CD raised concerns about siting sculpture prior to the environmental upgrading. He mentioned that there are still a lot of bad feelings in the air regarding the handling of the vandalized and demolished Hall, and the sculpture would be too vulnerable. He recommended to at least commence the ground work and planting prior to locating work.

BJ mentioned that she still would like to install during the biennial festival and whilst the McCall steam column is coming on. This would mean after the 15<sup>th</sup> of September and before 5<sup>th</sup> of November.

Realistically October.

**Action: delay the installation until work on the ground has commenced. JS to update on progress of work of landscaping undertaken.**

### 4. Legal speak

BJ sourced sourced a public art contract and further reading material regarding public art contracts . (Public Art on line and Hampshire County Council)

**Action: BJ to email sample contract to CS and JS . JS to seek appropriate clearing/ modifications within WBC of the sample contract, so that an amended version can be prepared to be signed between WBC and the artist.**

### 5. Publicity

4.1.Work has commenced on a tumbler blog that will document the project, including the student's work . Tumbler blog will be more complete for next meeting.

4.2.Various fliers/leaflets were shown at the meeting (as samples) and the decision was taken that a door to door leaflet will be produced , featuring the design of the students, a small amount of text, the various funders etc. and should be delivered to the doors at the time the sculpture will be installed.

**Action: BJ provide draft of intro text for next meeting. BJ's design student preparing mock up of design for next meeting . CS to "proof read".**

**Included in the funding list:**

Arts Council England  
Wirral Metropolitan Borough Council  
MIRIAD (Manchester Institute for Research in Art and Design)  
Everyone's Café (Central Park)  
Friends of the Park



**Action: CD to provide logo or correct wording for the last two sponsors.**

**4.3.** Postcards and any other publicity material will have as overarching design the work of the students.

#### **4.4 Interpretation panel**

A standard interpretation panel ( like the bird /coastal panels made along the coastal path) will be provided in the new landscaped area. The panel's text should contextualise the sculpture in relation to Liscard Hall, its function as Art school and the "spirit" of the sculptures.

**Action: CS to pool all the information , deadline for text for the Panel: 1<sup>st</sup> of September.**

**BJ and all others to send information to CS. CS will prepare the interpretation text and images .**

#### **4.5. Plaque**

A permanent plaque should also be produced and attached to the plinth, near the plinth, listing the generous support of all funders and including all funder's Logos.

**Action: BJ 's design student to prepare the "artwork". To be proofed via email.**

#### **4.6. Press**

A two strand strategy. BJ to prepare publicity material (press release , photos etc. for local and national press ) and sends it out under her name, cc'ing WBC, but WBC press office to do additional press work.

**Next meeting:**

**Scheduled for 30<sup>th</sup> of August. Sorry I need to cancel this date, since I am going to Germany to visit the Documenta! Can I propose Thursday the 6<sup>th</sup> of September?**



Posted On November 17, 2012

### Unveiling – Central Park

Later in the day .....

Members of Central Park Partnership gathered soon after noon together with our sculptor and three Seacombe councillors, and Cllr Mrs Chris Meaden whose portfolio includes Parks and Leisure, for the formal unveiling. The photos tell the story:



*Sculptor Brigitte Jurack and her work. By now the rain when we took the earlier photo at about 9.00am had abated, to be replaced absolutely perfectly by bright sunshine!*



*Members of the Central Park Partnership, led for many years by Mrs Diane Ledder – second from the right – were present to see the unveiling.*

Following our story on 5th November – see <http://seacombelabour.org/because-seacombe-and-new-brighton-matters/2012/11/05/> - we look forward, later today, to the unveiling of Brigitte Jurack's striking statue in Central Park's newly

completed outdoor performance area.



*The very striking statue*

We are fortunate in these times of austerity to have had this new feature previously agreed by the Central Park Partnership, working closely with the Council, from insurance money following the destruction of vandals of Liscard Hall.



*New gardens, stone block seating, new trees – and the performance area in the background.*

Posted On November 5, 2012

### Central Park performance area and garden nears completion



*This Springer Spaniel seems favourably impressed*

Seacombe is fortunate to have within its borders one of Wirral's finest parks. Central Park is soon to have a performance area with seating and gardens from the insurance money, and an arts grant, following the destruction by fire and demolition of Liscard Hall. This excellent new facility will be on the spot where the great Hall stood.

"Wirral News" has published an excellent article on the new development – just follow the link below.

<http://www.wirralnews.co.uk/wirral-news/local-wirral-news/wallasey-news/2012/10/31/liscard-hall-to-be-replaced-with-a-garden-and-sculpture-80491-32136210/>

The new development is largely due to the excellent work of Mrs Diane Ledder and the team of supporters of the park she has long inspired as Chair of the Central Park Partnership.



*Cllr Adrian Jones is seen here during a visit to the Hall shortly after it ceased to be an art college.*

A magnificent statue will be unveiled at lunch time on 17th November. It is the creation of a very innovative three dimensional artist, Brigitte Jurack, who says:



*A preview*

*young people of Wallasey. They have had so many great ideas for Central Park and I hope more of them become reality. I have put some of their ideas for new seating and ramps on the website and perhaps we could stage an annual piggy back race to raise some money for some of these wonderful proposals."*

Brigitte's sculpture will reflect the happiness of young people at play.

What could be better fitted for this site?



*This photograph was taken by Cllr John Salter as the Hall stood in ruins following the blaze that gutted it. It was demolished soon after.*

**Rebuilding Britain**  
Building an economy that works for working people - but we need your help.  
#LABOUR

#### News Feeds

- Milliband welcomes 3 newest Labour MPs to Parliament LabourList
- Hope Cameron will fully investigate Crosby rant claims - Dugher Labour Party [Privacy & Cookies Policy](#)
- Some people have a choice ahead or aren't Labour? Or their careers? LabourList
- Ed Milliband to headline Fabian New Year conference LabourList
- Business leaders say Gov's EBacc Certificates are wrong, Labour welcome CBI report on schools Labour Party News
- Vince Cable and George Osborne's failed economic plan has led to two years of almost no growth-Umumsa Labour Party News
- "Mr Speaker, after truth must come the best justice that can be provided 23 years late" Labour Matters
- Tory cuts force closure of Wardsworth police station Labour Matters
- Meadows School Leavers Assembly Upton Labour Community Action Team
- Torbay Mayor condemned for rogue landlord stance Labour Matters

#### Latest Tweets From Wirral Labour

- The Twitter API returned an error while processing your request. Please try again.

#### Community Links

- Mersey Femmes
- Wirral News

#### Political Links

- Angela Eagle MP
- Bidston St James Ward Labour Party
- Labour Home
- North West Labour Party
- Upton Labour Community Action Team
- Wallasey Labour Party
- Young Labour

#### Disclaimer

Seacombe Labour Party is not responsible for the content of external websites to which it may be linked. This is because:

1. Seacombe Labour Party does not produce them or maintain/update them.
2. Seacombe Labour Party cannot change them.
3. They can be changed without Seacombe

# GARDEN PLAN FOR HALL SITE



● Liscard Hall was a feature of Central Park Code NA

## New sculpture to be focal point

By **LIAM MURPHY**

A GARDEN, performance space and sculpture designed by an international artist will take the place of an

historic Wirral building destroyed following a blaze.

Liscard Hall was demolished after the fire in 2008.

● Full story: page 8



● The planned sculpture Code NA



# Future for Hall site revealed

## Sculpture to be centrepiece

By LIAM MURPHY

**A GARDEN and sculpture designed by an international artist will take the place of an historic Wirral building destroyed following a blaze.**

Liscard Hall was demolished after the fire in 2008 and insurance money plus a grant from the Arts Council is being used to fund the scheme in Central Park, Wallasey.

The Hall was famous as Wallasey School of Art and according to the German-born artist Brigitte Jurack her sculpture captures its "playful spirit", showing two young people piggy-backing". The work is to be joined by a third seated figure in early 2013.

The area around the sculpture is being redeveloped by Wirral Council with plans for a performance space with new seating, staging and flooring areas.

Brigitte said she had enjoyed working with the young people of Wallasey to develop the work. She said: "I have



● Liscard Hall as it was Code NA



● The cleared site Code NA



● Brigitte's sculpture Code NA

put some of their ideas for new seating and ramps on the website and perhaps we could stage an annual piggy back race to raise some money for some of these wonderful proposals."

She said her sculpture is called 'Just wait for me' "as the young people are waiting for friends or the next stage of

their life". Laurie Peake, public realm curator for the Liverpool Biennial: "No other park would have something as special as this and the self-esteem of the young people must have increased enormously by being involved in a project like this."

The official unveiling is on Saturday, November 17 from noon-1.30pm.

*Just Wait For Me*

Brigitte Jurack

2012

On the site of the former Wallasey School of Art

Based on original ideas from young people at Wallasey Youth Hub, The Oldershaw Academy, Weatherhead High School and St Mary's Catholic College.

Supported by Wirral Council, Central Park Partnership and Everyone's Café, Arts Council England, MIRIAD (Manchester Metropolitan University) and Castle Fine Arts Foundry.



# Liscard Hall

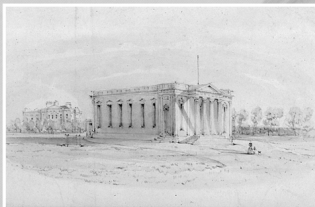

**Liscard Hall and the Wallasey School of Art**

Before you once stood Liscard Hall (below) on grounds that were bought for the public following the death of Harold Littledale in 1889. The Hall was built in 1835 by Harold's father-in-law, Sir John Tobin, following a successful business career. Before that it was farming land that belonged to the Prior and the Manor of Birkenhead. The views would have been clear to the Mersey in the east and the Welsh hills in the west. The house was large and white, in a neo-classical style like St John's Church (above) that Tobin built in the grounds. His 24-year old son was the first Vicar. The 97-acre grounds were named Central Park and became an important open area, saved from the building of houses and streets that completely surrounded the park as Wallasey grew from a series of villages into a town.

From the late 1800s through to 1982 Liscard Hall was used as Wallasey School of Art & Science. The Art School gained a tremendous national reputation as a centre of excellence and excitement for generations of art students, some of whom can be seen in these illustrations.

Between 1982 and 2003 the Hall was the base for a Youth Training Scheme 'Serve Wirral'. Pigeons occupied the building until 7th July 2008 when it was engulfed by fire and the damage was so great that Liscard Hall had to be demolished.



**Just Wait For Me (2012) by Brigitte Jurack**

*"No other park would have something as special as this and the self-esteem of the young people must have increased enormously by being involved since the very beginning in a project like this."* Laurie Peake, Liverpool Biennial.

In 2011 the artist Brigitte Jurack began working with young people from Wallasey to develop some ideas for the land where the Hall once stood. Appropriately for the site of the old School of Art, their creative talents came up with the ideas realised in the statues here now. Young people from Wallasey Youth Hub, St. Mary's Catholic College, Oldershaw Academy and Weatherhead High School made a series of small wax figures that inspired the sculptures. The figures are a reflection of aspects of youth, symbols of introspection as well as of friendship. Piggy-backing is playful and helpful, taking small steps from A to B while waiting for the next stage of a young life.

With thanks to Wirral Council, Williamson Art Gallery, The Oldershaw Academy, Central Park Partnership and Everyone's Cafe, Arts Council England, Manchester Institute for Research and Innovation in Art and Design (MIRIAD), Manchester Metropolitan University and Castle Fine Arts Foundry, Oswestry.



# DESIGNS FOR OUR PARK

Wallasey Youth Hub with the artist Brigitte Jurack



Birkenhead Park Visitor Centre  
Park Drive, Birkenhead CH41 4HY  
Nearest train station Birkenhead Park  
Mon-Sat 9:30 - 16:00 Tel: 0151 652 5197  
Monday 19th February - Saturday 10th March 2012

A Wirral Borough Council Project

# JUST WAIT FOR ME



## At Central Park

Part of the Central Park Redevelopment Scheme

The Friends of the Park and Everyone's Cafe are delighted to host the unveiling of **Just Wait For Me**, a collaboration between Wirral Borough Council, artist Brigitte Jurack and local young people from The Youth Hub, St Marys Catholic College, Weatherhead High School and The Oldershaw Academy. As part of the Central Park redevelopment scheme, a new sculpture and revamping of surrounding area have been created.

Two figures piggy-backing capture the banter and cheeky energy of youth, as championed by **The Wallasey Art School** which once stood on the site of the sculpture. Both the piggybakers and the third sitting figure await the arrival of today's young people who can make use of the new stage to show off their own creative talents.



You are invited to the opening ceremony on  
Saturday 15th October, 2-3.30pm

Refreshments will be provided in the cricket pavilion alongside  
an exhibition of works by the local young people.

**With support from:**  
**Everyone's Cafe**



Supported using public funding by  
**ARTS COUNCIL  
ENGLAND**





## PRESS RELEASE

### **‘Just Wait for Me’**

**New sculpture as part of redevelopment of Central Park, Liscard.**

**Unveiling Saturday 17<sup>th</sup> November 2012, 12 noon – 1.30pm, Central Park**

**(access off Liscard Road, between Eaton Avenue and Central Park Avenue, adjacent postcode: CH44 0AB)**

We are pleased to announce the unveiling of a new sculpture for Central Park. The sculpture is called ‘Just wait for me’ and is the result of a year-long collaboration between Wirral Council, local artist Brigitte Jurack and young people from across Wallasey.

The sculpture will be placed on the site of the former Liscard Hall which for many years was famous as Wallasey School of Art. The sculpture, which received support from the Arts Council of England, captures the playful spirit of the former art school, showing two young people piggy-backing. A third seated figure, watching the scene, will be added in early 2013.

The space around the sculpture is being redeveloped by Wirral Borough Council with new seating, staging and planted areas. On the day, a project display will be held in the Cricket Pavilion, including some small wax figures made by young people from Wallasey Youth Hub, St. Mary’s Catholic College and Weatherhead High School.

The artist Brigitte Jurack says:

*“I have really enjoyed working with the young people of Wallasey. They have had so many great ideas for Central Park and I hope more of them become reality. I have put some of their ideas for new seating and ramps on the website and perhaps we could stage an annual piggy back race to raise some money for some of these wonderful proposals.”*

*“In my research I was amazed at how important the Wallasey School of Art was. It had a big national reputation and a real sense of fun and experimenting. I think the piggy-backing figures capture some of that bravado and playfulness. I called it ‘Just wait for me’ as the young people are waiting for friends or the next stage of their life”*

Laurie Peak, Public Realm Curator for the Liverpool Biennial:

*“No other park would have something as special as this and the self-esteem of the young people must have increased enormously by being involved in a project like this since the very beginning.”*

Lewis Biggs, former Director of Liverpool Biennial:

*“It is quite unique to have an artist like Brigitte that is driven by that passion to create a new artwork for her own area. She has made something magical out of the everyday.”*



Alison McWatt, Head of Art and Design, St. Mary's Catholic College:

*"It has been such a fantastic opportunity for the students to see the sculpture when it was made in Brigitte's studio, to inspect the models, to discuss the ideas in more detail and to learn about the complicated process of casting."*

Rebecca Elliott, Media Arts Specialism Manager at Weatherhead High School:

*"The students felt really privileged working with an internationally known artist on the project for Central Park."*

### **About the artist**

Brigitte Jurack has a studio in Birkenhead and has lived in the Wallasey area for ten years. She lectures in sculpture at Manchester Metropolitan University and has exhibited her work widely including The British School of Athens, Bluecoat Gallery in Liverpool and galleries in the Ukraine, Japan, Australia, Germany, Dublin, Oslo and Brazil.

She is also a member of the artists' group Foreign Investment that have created projects with Liverpool street musicians, tower block residents in Sefton Park and ex-miners in St. Helens.

### **With thanks to**

Wirral Council

Wallasey Youth Hub

Williamson Art Gallery

Weatherhead High School

St. Mary's Catholic College

The Oldershaw Academy

Central Park Partnership and Everyone's Café

Arts Council England

Manchester Institute for Research and Innovation in Art and Design (MIRIAD),

Manchester Metropolitan University

Castle Fine Arts Foundry, Oswestry

### **Further info**

[www.brigittejurack.tumblr.com](http://www.brigittejurack.tumblr.com)

[www.brigittejurack.de](http://www.brigittejurack.de)

### **For interviews and photographs**

Lucas Wilson, project publicity

Email: [lucasernestwilson@gmail.com](mailto:lucasernestwilson@gmail.com)

Mobile: 07961 579578

+ Wirral Council Press Office

### **Directions**

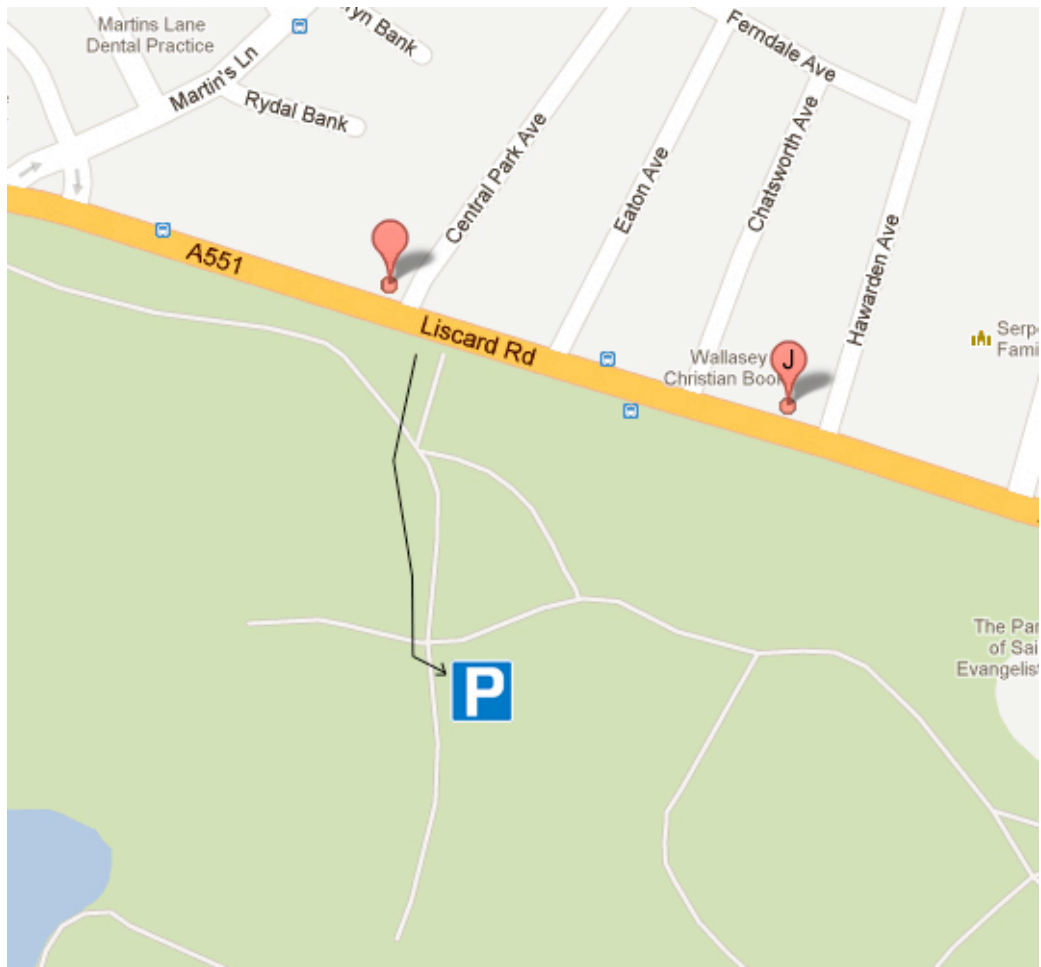

**Attached**

Just Wait For Me Foundry closeup (jpg)

A Wirral Council Project

# JUST WAIT FOR ME



**At Central Park**  
Part of the Central Park Redevelopment Scheme

## Just Wait For Me

Central Park Partnership and Everyone's Café are delighted to present the new sculpture *Just Wait For Me*, a collaboration between Wirral Council, artist Brigitte Jurack and young people from Wallasey Youth Hub, St. Mary's Catholic College, The Oldershaw Academy and Weatherhead High School.

The sculpture sits on the site of the former Wallasey School of Art (once Liscard Hall) and is part of Wirral Council's wider redevelopment of Central Park. The sculpture captures the playful spirit of the former Art School showing two figures piggy-backing. It has been inspired by small wax models made by local young people and some of these models will be on display in the Cricket Pavilion.



You are invited to the opening ceremony on  
Saturday 17th November 12 noon - 1.30pm

Refreshments will be available in the Cricket Pavilion.

Central Park Partnership and Everyone's Café



Supported using public funding by  
**ARTS COUNCIL  
ENGLAND**



**WIRRAL**

# Merseyside region

Highlighted: Wallasey, Wirral



## Studios and public sculptures of youth



### Studios (orange)

- 1 Former Technical College, Bootle
- 2 Domestic house studio, Wallasey
- 3 NPO Motors, Oxtot
- 4 Alternator Studio

### Public sculptures of youth (blue)

- 1 Edward Richardson's *Bluecoat School boy* (Chester)
- 2 Frederick William Pomeroy *Navigation and Learning*
- 3 Edward Carter Preston *Monument to the world Boy Scout Jamboree*
- 4 William Gascombe John *Port Sunlight War Memorial*
- 5 Sir George Frampton *Peter Pan*
- 6 Diane Gorvin *Bo Peep and her sheep* (Birchwood)



# Just wait for me, Central Park (2012-13)

